



The BM5S is the bearingless motor of BM5 family, large volume disc valve, high pressure motor.

CHARACTERISTIC FEATURES

- Advanced design in disc distribution flow, which can provide better performance at low speed.
- The valve can automatically compensate for wear, so a higher volumetric efficiency can be obtained.

Main Specification

The main specification and performance data are same as BM5, please refer to the BM5 section on page 34-37.

Figure A

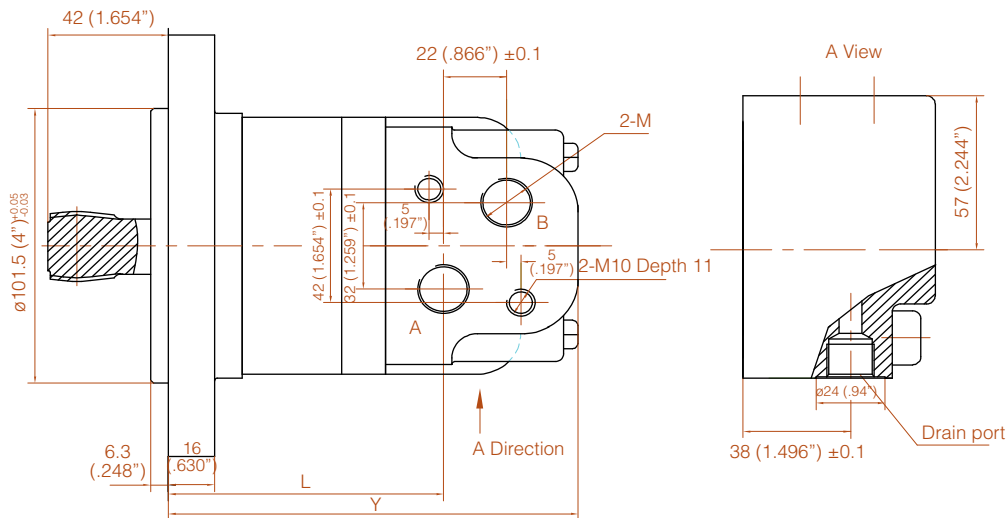

Displacement	80	100	160	200	250	280	305	400	500
Y	123.5	126.5	138	146	155	160.2	164	181	199
	4.862	4.980	5.433	5.748	6.102	6.307	6.457	7.126	7.835
L	75.5	78.5	90	98	107	112.2	116	123	151
	2.972	3.091	3.543	3.858	4.213	4.417	4.567	4.843	5.945

Figuration B

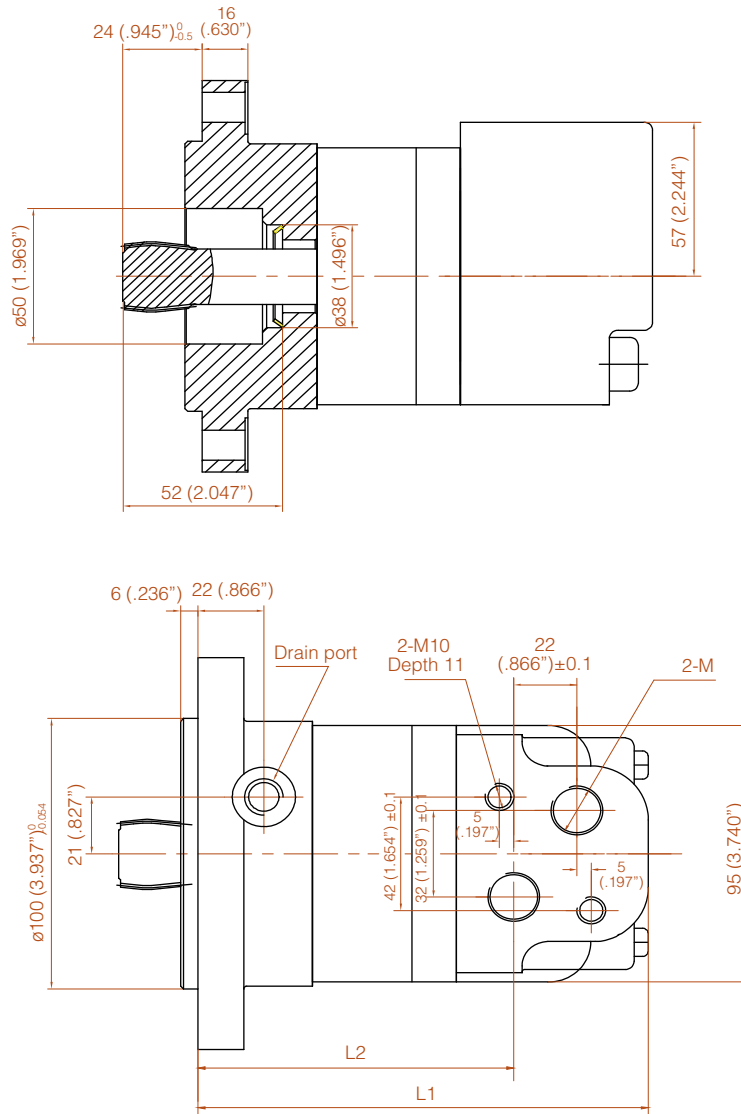

Displacement	80	100	160	200	250	280	305	400	500
L1	138	141	152.5	160.5	169.5	174.5	178.5	195.5	213.5
	5.433	5.551	6.004	6.319	6.673	6.870	7.028	7.697	8.406
L2	90	93	104.5	112.5	121.5	126.5	130.5	137.5	165.5
	3.543	3.661	4.114	4.429	4.783	4.980	5.138	5.413	6.516

Flange A

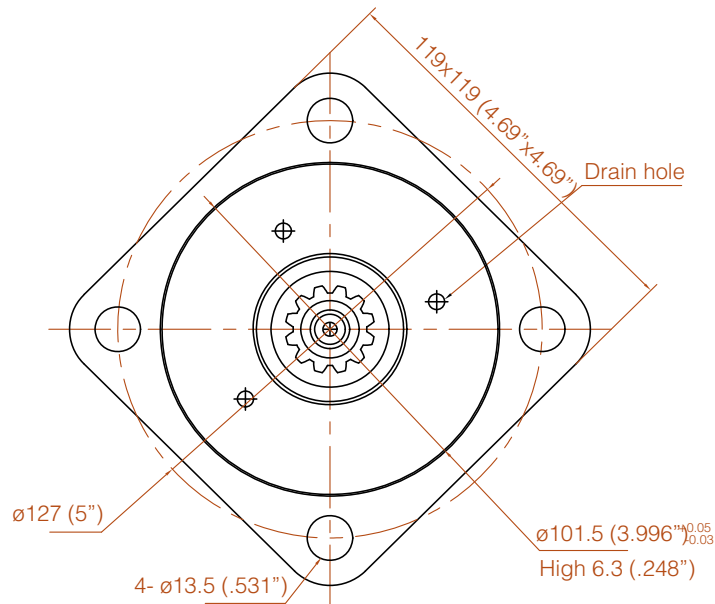

Flange B

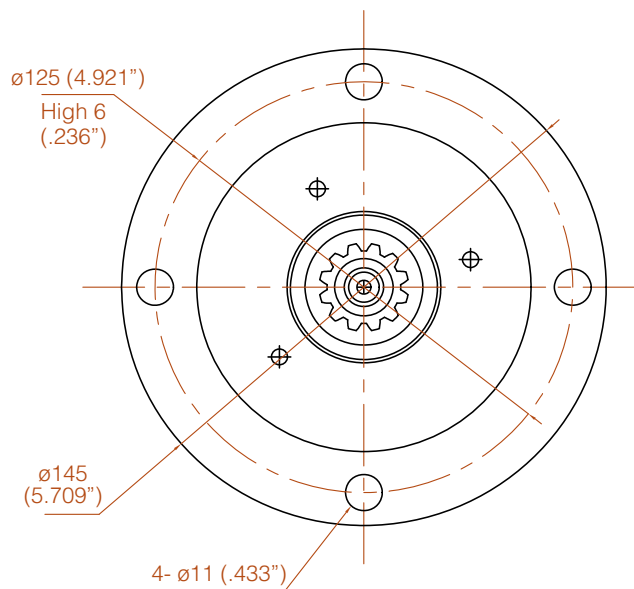

Back Housing A

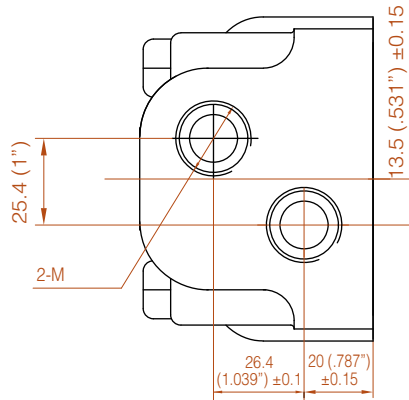

Back Housing B

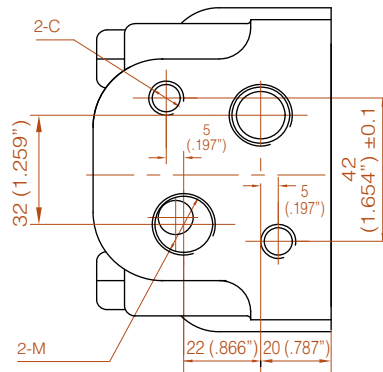

Back Housing C

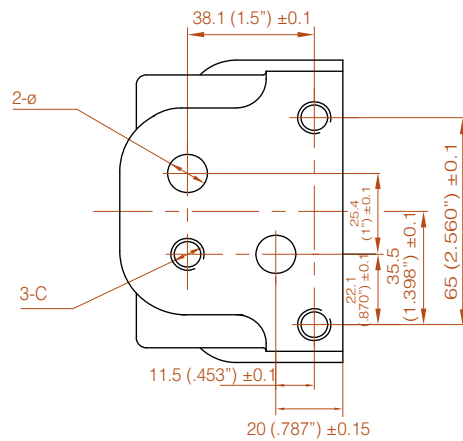

Shaft A

External involute spline data

Pitch	12/24
Pressure angle	30°
Number of teeth	12
Pitch dia.	ø25.4 (1")
Major dia.	ø26.6 ^{+0.20} / ₀ (1.047 ^{+0.008} / ₀)
Minor dia.	ø22 ^{+0.20} / ₀ (0.866 ^{+0.008} / ₀)
Tooth thickness	4.3 ^{-0.124} / _{-0.162} (0.170 ^{-0.005} / _{-0.006})
Pin dia.	ø3.087 (0.122")
Measurement between pins	30.1 ^{+0.118} / _{+0.064} (1.185 ^{+0.005} / _{+0.003})

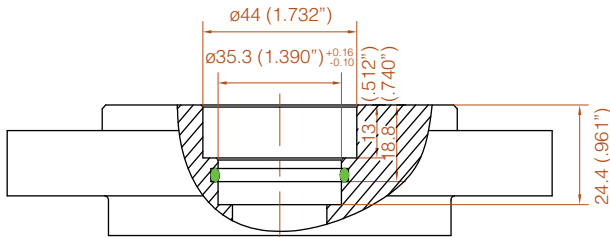

Dimensions of the attached component

Shaft B

External involute spline data

Pitch	12/24
Pressure angle	30°
Number of teeth	12
Pitch dia.	ø25.4 (1")
Major dia.	ø26.6 ^{+0.20} / ₀ (1.047 ^{+0.008} / ₀)
Minor dia.	ø22 ^{+0.20} / ₀ (0.866 ^{+0.008} / ₀)
Tooth thickness	4.3 ^{-0.124} / _{-0.162} (0.170 ^{-0.005} / _{-0.006})
Pin dia.	ø3.087 (0.122")
Measurement between pins	30.1 ^{+0.118} / _{+0.064} (1.185 ^{+0.005} / _{+0.003})

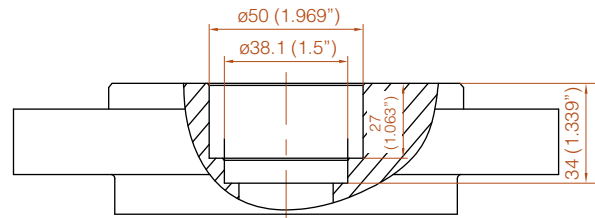

Dimensions of the attached component

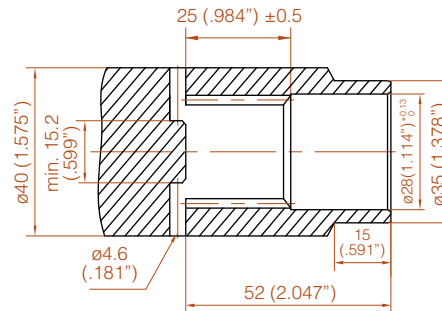
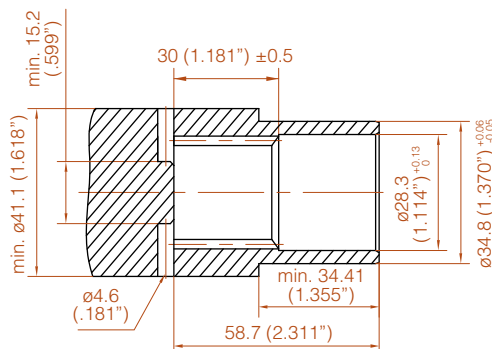

BM5S Code number & Order information

Choose an option
for each category

BM5S

--	--	--	--	--	--	--	--	--

Figuration

A - Refer to Drawing Page **B** - Refer to Drawing Page

Displacement (cc)

A - 80 **B** - 100 **C** - 125 **D** - 160 **E** - 200 **F** - 305 **G** - 400 **H** - 500

Flange & Pilot (mm)

A - Square flange 119x119 (4.685"x4.685"), 4- ϕ 13.5 (.531")
distributing ϕ 127 (5"), Pilot ϕ 101.5x6.4 (3.997"x.252")
B - Circular flange 4- ϕ 11 (.433") distributing ϕ 125 (4.92"),
Pilot ϕ 100x6 (3.937"x.236")

Shaft & Key (mm)

A - Refer to Drawing Page **B** - Refer to Drawing Page

Back Housing

A - Refer to Drawing Page **B** - Refer to Drawing Page **C** - Refer to Drawing Page

Oil Port

A - 2-M22x1.5 **B** - 2-G1/2 **C** - 2- ϕ 12 (.472")

Link Thread on Port Surface

A - None **B** - 2-M10 **C** - 2-3/8-16UNC

Drain Port

A - None **B** - M14x1.5 **C** - G1/4 **D** - 7/16-20UNF

Order example: BM5SBCBBAABA

Other configuration and/or mounting types are available upon request.