

PLC SERIE

- CLOCKWISE ROTATION
- SAE B -2 BOLT MOUNTING
- 1 1/4" STRAIGHT KEY SHAFT

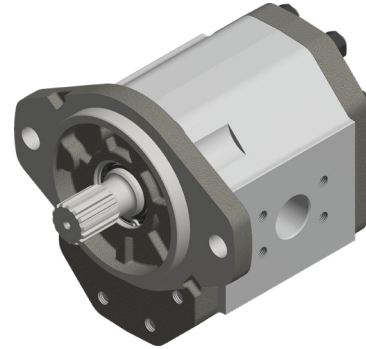

ALSO AVAILABLE

- COUNTERCLOCKWISE ROTATION
- OTHER SHAFTS & FLANGES
- SMALLER DISPLACEMENTS
- TANDEM PUMPS & MULTIPLE PUMPS

PART NUMBER	DISPLACEMENT IN <sup>3</sup> (CM <sup>3</sup> ) / REV.	DIMENSION A (IN)	GPM @ 1800 RPM	MAX RPM	MAX PSI	PORTS	
						INLET	OUTLET
1PLC 125D H09M	5.08 (83)	7.87	39.6	3000	3625	1 1/2" CODE FLANGE 61 (M12 THREAD)	1 1/4" CODE FLANGE 61 (M10 THREAD)
1PLC 150D H09M	6.1 (100)	8.19	47.5	3000	3625	2" CODE FLANGE 61 (M12 THREAD)	1 1/2" CODE FLANGE 61 (M12 THREAD)
1PLC 175D H09M	7.12 (116)	8.5	55.5	2500	3625		
1PLC 200D H09M	8.13 (133)	8.86	63.3	2000	2900		
1PLC 225D H09M	9.15 (150)	9.17	71.3	1750	2540		

