

HYDROLICO

POUR TOUS VOS BESOINS HYDRAULIQUES
FOR ALL YOUR HYDRAULIC NEEDS

CATALOGUE • 2024 • CATALOG

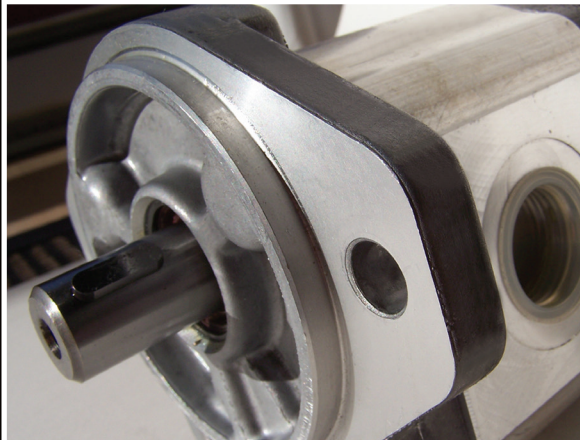

Technical drawings of hydraulic components with dimensions in mm.

- HYDRAULIC CYLINDERS ■
- MOTORS ■
- POWER UNITS ■ Ø1 1/4"
- ELECTRIC MOTORS ■
- PUMPS ■
- VALVES, SUBPLATES & MANIFOLDS ■
- DIVIDERS ■
- ACCUMULATORS ■
- ACCESSORIES ■
- TANK ACCESSORIES ■
- FILTERS ■
- TANKS ■
- PNEUMATICS ■



ABOUT HYDROLICO

Fluid power systems has been our passion since more than 25 years. Over these years, we have built a dedicated team of experts who thrive to continuously seek to improve our products and services in order to be your fluid power supplier of choice. This allowed us to be recognize has a strong hydraulic leader with a solid reputation in the North America fluid power industry.

SERVICE, SALES & EFFICIENCY

We are your hydraulics specialist. Our main objective is your complete satisfaction. Hydrolico offers reliable, proven and durable products in accordance with application and technical specifications. Our experienced sales team along with our professional, attentive customer service department will work in unison with our technical division to support your application needs.

Meeting and exceeding your demands are our priorities. Hydrolico thus offers you a wide range of warehoused products that can be modified and altered to your specifications, points of sales across Canada and the United States, facilities for production in Asia with on-site supervision by Hydrolico personnel and customized local production and prototypes available through our Canadian, US plant and affiliated partners.

We have surrounded our core products with several major brands of complementary products, providing a complete line to meet our customer's demand. Our product portfolio makes us your own solution supplier for all your hydraulic and pneumatic essentials.

HC HYDRO CUSTOM BRAND

Our proprietary brand, HC Hydro Custom, offers a wide range of hydraulic products. We design, develop and engineer all of our products with the highest standards of the industry. Our recognized expertise in hydraulic cylinders allows us to develop innovative solutions capable of meeting the most specific requirements. Thanks to our factories in Canada and Asia, we have developed a production capacity capable of responding to all your requests quickly and efficiently.





TABLE OF CONTENTS

HYDRAULIC CYLINDERS

WELDED CYLINDERS - BUSHING TYPE	6
WELDED CYLINDERS - CLEVIS TYPE	9
WELDED CYLINDERS - THROUGH HOLE TYPE	13
WELDED CYLINDERS - THREADED CLEVIS TYPE	17
TIE-ROD CYLINDERS - 2500 PSI	21
TIE-ROD CYLINDERS - 3000 PSI	24
TELESCOPIC CYLINDERS - SINGLE ACTING	28
SNOW PLOW CYLINDERS	29
CYLINDERS COMPONENTS	30
SEAL KITS	35

MOTORS

LOW SPEED HIGH TORQUE MOTORS	38
MOTOR WITH INTEGRATED BRAKES	51
MOTORS ACCESSORIES	52
STEERING UNITS	53
GEAR MOTORS	54
PISTON MOTORS	56

POWER UNITS

POWER PACKS	58
-------------	----

ELECTRIC MOTORS

ELECTRIC MOTORS	64
DIRECT MOUNT "PUMP-MOTOR ASSEMBLIES"	65

PUMPS

ALUMINUM GEAR PUMPS	68
QUIET GEAR PUMPS	72
CAST IRON GEAR PUMPS	73
VANE PUMPS	74
PISTON PUMPS	76
PTO PUMPS, 2 STAGE PUMPS	78
HAND PUMPS	79
HYDROSTATIC PUMPS	80

VALVES, SUBPLATES & MANIFOLDS

DIRECTIONAL VALVES - MONOBLOCK TYPE	85
DIRECTIONAL VALVES - SECTIONAL TYPE	92
PROPORTIONAL DIRECTIONAL VALVES	98
RADIO & PNEUMATIC CONTROLS	100
CABLES & LEVERS	102
SOLENOID OPERATED DIRECTIONAL VALVES	104
MODULAR VALVES	108
MANIFOLD BLOCKS	109

SOLENOID VALVES	112
ELECTRIC FLOW DIVERTERS	114
JOYSTICK HANDLES	118
MANUAL FLOW DIVERTERS	118
BALL VALVES	120
CHECK VALVES	120
HOLDING VALVES	122
RELIEF VALVES & PRESSURE CONTROLS	126
FLOW CONTROL VALVES	130
SUN VS WINNER CROSSOVERS	133

DIVIDERS

FLOW DIVIDERS - CARTRIDGE TYPE	134
FLOW DIVIDERS - GEAR TYPE	135

ACCUMULATORS

ACCUMULATORS	136
PISTON ACCUMULATORS - ACCESSORIES	137

ACCESSORIES

ELECTRICAL SWITCHES AND TRANSDUCERS	138
PRESSURE GAUGES	139

TANK ACCESSORIES

BREATHERS	140
LEVEL GAUGES, TANK COVERS	142
BELLHOUSINGS & COUPLINGS	143

FILTERS

RETURN FILTERS	144
HIGH PRESSURE FILTERS	148
STRAINERS	149

TANKS

INDUSTRIAL TANKS	150
MOBILE TANKS	151

PNEUMATICS

PROCESS VALVES	156
CYLINDERS	158
MECHANICAL VALVES	163
DIRECTIONAL VALVES	164
FILTERS, REGULATORS & LUBRIFICATORS	165
ONE TOUCH FITTING	166
TUBE	167



HC Hydro Custom

Thanks to our dedicated and experienced team, the Hydro Custom cylinder brand has carved out a place among the market leaders in hydraulics, and developed a stellar reputation in North America.

Conceived by Hydrolico, HC Hydro Custom provides a range of products designed in Canada to meet your needs and your specifications. These products are produced in our combined 200,000 ft² production facilities in Canada, USA and Asia. We use an integrated production process managed by the engineering team at our Canadian head office and carefully monitor quality assurance and quality control. Hydro Custom products come with a one-year limited warranty, and our after-sale service is unequalled in the industry.



Custom Cylinders offers you many benefits :

- Experienced adviser in development and design
- Innovative manufacturing solutions tailored to the needs of the clients
- Customized manufacturing solutions adapted to the speed, quantity and desired price
- All our cylinders are designed with the renown Hallite seals, with a few exceptions where other suppliers, such as Trelleborg, are better suited for the application
- A variety of specialized services that can be customized to your needs, including validation of 3D prototypes, repeated rigorous testing, installation and assembly in a contaminant-free environment
- A wide range of standard cylinders provided from our three warehouses located across North America, in addition to several points of service from trading partners
- A product with a quality/price ratio unmatched in our market

Because we design our own models and have our own production facilities, we can stand behind our products 100% from start to finish. We offer full hydraulic component repair and modification services across Canada.

We are proud to contribute to the success of many companies that produce mobile hydraulic equipment to various types of industries.



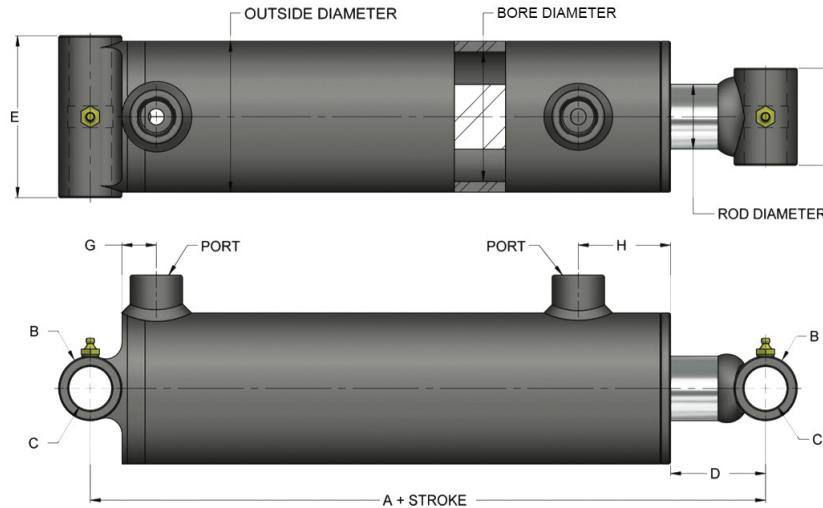

MODEL CODE	CYLINDER BORE	OUTSIDE DIAMETER	ROD DIAMETER	A	B	C	D	E	F	G	H	PORT SIZE*
BU15XX-S	1.50	1.875	1.00	8.00	1.25	0.76	2.62	2.25	2.00	1.06	1.87	SAE-04
BU20XX-S	2.00	2.375	1.25	8.00	1.50	1.01	2.25	2.75	2.25	1.00	2.06	SAE-06
BU25XX-S	2.50	2.875	1.50	8.00	1.50	1.01	2.25	3.25	2.25	0.81	2.18	SAE-08
BU30XX-S	3.00	3.50	1.50	8.00	1.50	1.01	2.25	3.75	2.25	0.81	2.18	SAE-08
BU35XX-S	3.50	4.00	1.75	10.00	2.00	1.26	4.00	4.25	2.25	0.81	2.18	SAE-08
BU40XX-S	4.00	4.50	2.00	10.00	2.25	1.51	3.75	4.75	2.50	0.81	2.18	SAE-08
BU50XX-S	5.00	5.50	2.50	12.00	3.00	1.76**	3.50	5.75	3.25	1.25	2.75	SAE-12

* NPT PORTS ARE ALSO AVAILABLE
 ** PIN SIZE WITH INSERT, 2" WHEN REMOVED
 MAXIMUM RETRACTED WORKING PRESSURE : 3000 PSI
 MAXIMUM EXTENDED WORKING PRESSURE : SEE TABLE
 RETRACTED AND STROKE TOLERANCE ± 1/8"

MODEL CODE	BORE X STROKE	DIMENSIONS		ROD DIAMETER	PIN SIZE	PORT SIZE*	COLUMN LOADS (LBS)	PRESSURE (PSI)	WEIGHT (LBS)
		RETRACTED	EXTENDED						
BU1504-S	1.5" X 4"	12"	16"	1"	3/4"	SAE-04	5300	3000	8
BU1506-S	1.5" X 6"	14"	20"				5300	3000	9
BU1508-S	1.5" X 8"	16"	24"				5300	3000	10
BU1510-S	1.5" X 10"	18"	28"				5300	3000	12
BU1512-S	1.5" X 12"	20"	32"				5300	3000	13
BU1514-S	1.5" X 14"	22"	36"				5300	3000	14
BU1516-S	1.5" X 16"	24"	40"				5300	3000	15
BU1518-S	1.5" X 18"	26"	44"				4800	2700	17
BU1520-S	1.5" X 20"	28"	48"				4000	2300	18
BU1524-S	1.5" X 24"	32"	56"				3000	1700	20
BU2004-S	2" X 4"	12"	16"	1-1/4"	1"	SAE-06	9400	3000	12
BU2006-S	2" X 6"	14"	20"				9400	3000	13
BU2008-S	2" X 8"	16"	24"				9400	3000	15
BU2010-S	2" X 10"	18"	28"				9400	3000	17
BU2012-S	2" X 12"	20"	32"				9400	3000	19
BU2014-S	2" X 14"	22"	36"				9400	3000	20
BU2016-S	2" X 16"	24"	40"				9400	3000	22
BU2018-S	2" X 18"	26"	44"				9400	3000	24
BU2020-S	2" X 20"	28"	48"				9400	3000	25
BU2024-S	2" X 24"	32"	56"				7300	2300	29
BU2028-S	2" X 28"	36"	64"				5600	1700	32
BU2030-S	2" X 30"	38"	68"				4900	1500	34
BU2032-S	2" X 32"	40"	72"				4400	1400	35
BU2036-S	2" X 36"	44"	80"				3500	1100	39
BU2040-S	2" X 40"	48"	88"				2900	900	42
BU2048-S	2" X 48"	56"	104"				2100	600	49

COLUMN LOAD IS THE MAXIMUM PUSHING LOAD SUGGESTED USING A MINIMUM SAFETY FACTOR OF 2 AND BASED ON A PIN TO PIN MOUNTING CALCULATION.

HYDRO CUSTOM IS NOT RESPONSIBLE FOR INCORRECT RESULTS OBTAINED WITH FIGURES IN THIS DOCUMENT. INFORMATION IS FOR REFERENCE ONLY. NO OTHER CONDITIONS ARE EXPRESSED OR IMPLIED.

MODEL CODE	BORE X STROKE	DIMENSIONS		ROD DIAMETER	PIN SIZE	PORT SIZE*	COLUMN LOADS (LBS)	PRESSURE (PSI)	WEIGHT (LBS)			
		RETRACTED	EXTENDED									
BU2504-S	2.5" X 4"	12"	16"	1-1/2"	1"	SAE-08	14700	3000	16			
BU2506-S	2.5" X 6"	14"	20"				14700	3000	18			
BU2508-S	2.5" X 8"	16"	24"				14700	3000	20			
BU2510-S	2.5" X 10"	18"	28"				14700	3000	22			
BU2512-S	2.5" X 12"	20"	32"				14700	3000	24			
BU2514-S	2.5" X 14"	22"	36"				14700	3000	27			
BU2516-S	2.5" X 16"	24"	40"				14700	3000	29			
BU2518-S	2.5" X 18"	26"	44"				14700	3000	31			
BU2520-S	2.5" X 20"	28"	48"				14700	3000	33			
BU2524-S	2.5" X 24"	32"	56"				14700	3000	38			
BU2528-S	2.5" X 28"	36"	64"				11600	2300	42			
BU2530-S	2.5" X 30"	38"	68"				10300	2100	45			
BU2532-S	2.5" X 32"	40"	72"				9200	1800	47			
BU2536-S	2.5" X 36"	44"	80"				7400	1500	51			
BU2540-S	2.5" X 40"	48"	88"				6100	1200	56			
BU2548-S	2.5" X 48"	56"	104"				4400	800	65			
BU3004-S	3" X 4"	12"	16"				1-1/2"	1"	SAE-08	21200	3000	19
BU3006-S	3" X 6"	14"	20"							21200	3000	22
BU3008-S	3" X 8"	16"	24"							21200	3000	24
BU3010-S	3" X 10"	18"	28"							21200	3000	27
BU3012-S	3" X 12"	20"	32"	21200	3000	29						
BU3014-S	3" X 14"	22"	36"	21200	3000	32						
BU3016-S	3" X 16"	24"	40"	21200	3000	34						
BU3018-S	3" X 18"	26"	44"	21200	3000	36						
BU3020-S	3" X 20"	28"	48"	20700	2900	39						
BU3024-S	3" X 24"	32"	56"	15200	2100	44						
BU3028-S	3" X 28"	36"	64"	11600	1600	49						
BU3030-S	3" X 30"	38"	68"	10300	1400	51						
BU3032-S	3" X 32"	40"	72"	9200	1300	53						
BU3036-S	3" X 36"	44"	80"	7400	1000	58						
BU3040-S	3" X 40"	48"	88"	6100	800	63						
BU3048-S	3" X 48"	56"	104"	4400	600	73						
BU3504-S	3.5" X 4"	14"	18"	1-3/4"	1-1/4"	SAE-08				28800	3000	27
BU3506-S	3.5" X 6"	16"	22"							28800	3000	30
BU3508-S	3.5" X 8"	18"	26"							28800	3000	33
BU3510-S	3.5" X 10"	20"	30"							28800	3000	36
BU3512-S	3.5" X 12"	22"	34"				28800	3000	39			
BU3514-S	3.5" X 14"	24"	38"				28800	3000	42			
BU3516-S	3.5" X 16"	26"	42"				28800	3000	45			
BU3518-S	3.5" X 18"	28"	46"				28800	3000	48			
BU3520-S	3.5" X 20"	30"	50"				28800	3000	51			
BU3524-S	3.5" X 24"	34"	58"				26200	2700	57			
BU3528-S	3.5" X 28"	38"	66"				20200	2100	63			
BU3530-S	3.5" X 30"	40"	70"				18000	1800	66			
BU3532-S	3.5" X 32"	42"	74"				16100	1600	69			
BU3536-S	3.5" X 36"	46"	82"				13100	1300	75			
BU3540-S	3.5" X 40"	50"	90"				10900	1100	81			
BU3548-S	3.5" X 48"	58"	106"				7800	800	94			

COLUMN LOAD IS THE MAXIMUM PUSHING LOAD SUGGESTED USING A MINIMUM SAFETY FACTOR OF 2 AND BASED ON A PIN TO PIN MOUNTING CALCULATION.

HYDRO CUSTOM IS NOT RESPONSIBLE FOR INCORRECT RESULTS OBTAINED WITH FIGURES IN THIS DOCUMENT. INFORMATION IS FOR REFERENCE ONLY. NO OTHER CONDITIONS ARE EXPRESSED OR IMPLIED.



MODEL CODE	BORE X STROKE	DIMENSIONS		ROD DIAMETER	PIN SIZE	PORT SIZE*	COLUMN LOADS (LBS)	PRESSURE (PSI)	WEIGHT (LBS)
		RETRACTED	EXTENDED						
BU4004-S	4" X 4"	14"	18"	2"	1-1/2"	SAE-08	37600	3000	34
BU4006-S	4" X 6"	16"	22"				37600	3000	38
BU4008-S	4" X 8"	18"	26"				37600	3000	41
BU4010-S	4" X 10"	20"	30"				37600	3000	45
BU4012-S	4" X 12"	22"	34"				37600	3000	49
BU4014-S	4" X 14"	24"	38"				37600	3000	52
BU4016-S	4" X 16"	26"	42"				37600	3000	56
BU4018-S	4" X 18"	28"	46"				37600	3000	59
BU4020-S	4" X 20"	30"	50"				37600	3000	63
BU4024-S	4" X 24"	34"	58"				37600	3000	70
BU4028-S	4" X 28"	38"	66"				34600	2700	78
BU4030-S	4" X 30"	40"	70"				30700	2400	81
BU4032-S	4" X 32"	42"	74"				27500	2100	85
BU4036-S	4" X 36"	46"	82"				22400	1700	92
BU4040-S	4" X 40"	50"	90"				18600	1400	99
BU4048-S	4" X 48"	58"	106"				13400	1000	114
BU5004-S	5" X 4"	16"	20"				2-1/2"	1-3/4"	SAE-12
BU5006-S	5" X 6"	18"	24"	58900	3000	69			
BU5008-S	5" X 8"	20"	28"	58900	3000	75			
BU5010-S	5" X 10"	22"	32"	58900	3000	80			
BU5012-S	5" X 12"	24"	36"	58900	3000	85			
BU5014-S	5" X 14"	26"	40"	58900	3000	90			
BU5016-S	5" X 16"	28"	44"	58900	3000	96			
BU5018-S	5" X 18"	30"	48"	58900	3000	101			
BU5020-S	5" X 20"	32"	52"	58900	3000	106			
BU5024-S	5" X 24"	36"	60"	58900	3000	116			
BU5028-S	5" X 28"	40"	68"	58900	3000	126			
BU5030-S	5" X 30"	42"	72"	58900	3000	131			
BU5032-S	5" X 32"	44"	76"	58900	3000	136			
BU5036-S	5" X 36"	48"	84"	52100	2600	147			
BU5040-S	5" X 40"	52"	92"	43400	2200	157			
BU5048-S	5" X 48"	60"	108"	31500	1600	177			

COLUMN LOAD IS THE MAXIMUM PUSHING LOAD SUGGESTED USING A MINIMUM SAFETY FACTOR OF 2 AND BASED ON A PIN TO PIN MOUNTING CALCULATION.

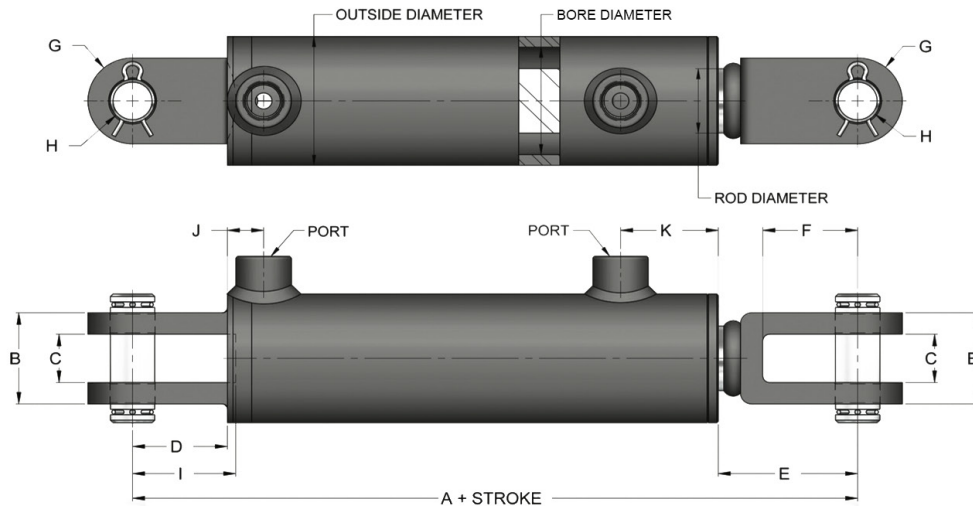

MODEL CODE	CYLINDER BORE	OUTSIDE DIAMETER	ROD DIAMETER	*A	B	C	D	*E	F	G	H	I	J	K	PORT SIZE*
CL15XX-S	1.50	1.875	1.00	8.25	1.62	0.87	1.37	2.25	1.37	1.50	0.76	-	0.93	1.87	SAE-04
CL20XX-S	2.00	2.375	1.25	10.25	2.12	1.12	2.12	3.12	2.12	2.00	1.01	-	1.00	2.06	SAE-06
CL25XX-S	2.50	2.875	1.50	10.25	2.12	1.12	2.12	3.12	2.12	2.00	1.01	-	0.81	2.18	SAE-08
CL30XX-S	3.00	3.50	1.50	10.25	2.12	1.12	2.12	3.12	2.12	2.00	1.01	-	0.81	2.18	SAE-08
CL35XX-S	3.50	4.00	1.75	10.25	2.37	1.12	2.00	3.12	2.12	2.00	1.01	2.12	0.93	2.18	SAE-08
CL40XX-S	4.00	4.50	2.00	10.25	2.37	1.12	1.75	3.12	2.00	2.00	1.01	2.00	1.06	2.18	SAE-08
CL50XX-S	5.00	5.50	2.50	13.00	3.12	1.62	2.25	3.62	2.25	3.00	1.51	-	1.37	2.75	SAE-12

FOR 2" TO 4" BORE, 8" STROKE : A = 12.25", E = 5.12"
 * NPT PORTS ARE ALSO AVAILABLE FROM 1.5" TO 4" BORE CYLINDERS
 MAXIMUM RETRACTED WORKING PRESSURE : 3000 PSI
 MAXIMUM EXTENDED WORKING PRESSURE : SEE TABLE
 RETRACTED AND STROKE TOLERANCE ± 1/8"

MODEL CODE	BORE X STROKE	DIMENSIONS		ROD DIAMETER	PIN SIZE	PORT SIZE*	COLUMN LOADS (LBS)	PRESSURE (PSI)	WEIGHT (LBS)
		RETRACTED	EXTENDED						
CL1504-S	1.5" X 4"	12-1/4"	16-1/4"	1"	3/4"	SAE-04	5300	3000	8
CL1506-S	1.5" X 6"	14-1/4"	20-1/4"				5300	3000	9
CL1508-S	1.5" X 8"	16-1/4"	24-1/4"				5300	3000	11
CL1510-S	1.5" X 10"	18-1/4"	28-1/4"				5300	3000	12
CL1512-S	1.5" X 12"	20-1/4"	32-1/4"				5300	3000	13
CL1514-S	1.5" X 14"	22-1/4"	36-1/4"				5300	3000	14
CL1516-S	1.5" X 16"	24-1/4"	40-1/4"				5300	3000	15
CL1518-S	1.5" X 18"	26-1/4"	44-1/4"				4800	2700	17
CL1520-S	1.5" X 20"	28-1/4"	48-1/4"				4000	2200	18
CL1524-S	1.5" X 24"	32-1/4"	56-1/4"				2900	1600	20
CL2004-S	2" X 4"	14-1/4"	18-1/4"	1-1/4"	1"	SAE-06	9400	3000	14
CL2006-S	2" X 6"	16-1/4"	22-1/4"				9400	3000	16
CL2008-S	2" X 8"	20-1/4"	28-1/4"				9400	3000	18
CL2010-S	2" X 10"	20-1/4"	30-1/4"				9400	3000	19
CL2012-S	2" X 12"	22-1/4"	34-1/4"				9400	3000	21
CL2014-S	2" X 14"	24-1/4"	38-1/4"				9400	3000	23
CL2016-S	2" X 16"	26-1/4"	42-1/4"				9400	3000	25
CL2018-S	2" X 18"	28-1/4"	46-1/4"				9400	3000	26
CL2020-S	2" X 20"	30-1/4"	50-1/4"				9100	2900	28
CL2024-S	2" X 24"	34-1/4"	58-1/4"				6700	2100	31
CL2028-S	2" X 28"	38-1/4"	66-1/4"				5200	1600	35
CL2030-S	2" X 30"	40-1/4"	70-1/4"				4600	1400	36
CL2032-S	2" X 32"	42-1/4"	74-1/4"				4100	1300	38
CL2034-S	2" X 34"	44-1/4"	78-1/4"				3700	1100	40
CL2036-S	2" X 36"	46-1/4"	82-1/4"				3400	1000	42
CL2040-S	2" X 40"	50-1/4"	90-1/4"				2800	800	45
CL2048-S	2" X 48"	58-1/4"	106-1/4"				2000	600	52

COLUMN LOAD IS THE MAXIMUM PUSHING LOAD SUGGESTED USING A MINIMUM SAFETY FACTOR OF 2 AND BASED ON A PIN TO PIN MOUNTING CALCULATION.

HYDRO CUSTOM IS NOT RESPONSIBLE FOR INCORRECT RESULTS OBTAINED WITH FIGURES IN THIS DOCUMENT. INFORMATION IS FOR REFERENCE ONLY. NO OTHER CONDITIONS ARE EXPRESSED OR IMPLIED.

HYDRAULIC CYLINDERS



MODEL CODE	BORE X STROKE	DIMENSIONS		ROD DIAMETER	PIN SIZE	PORT SIZE*	COLUMN LOADS (LBS)	PRESSURE (PSI)	WEIGHT (LBS)
		RETRACTED	EXTENDED						
CL2504-S	2.5" X 4"	14-1/4"	18-1/4"	1-1/2"	1"	SAE-08	14700	3000	18
CL2506-S	2.5" X 6"	16-1/4"	22-1/4"				14700	3000	20
CL2508-S	2.5" X 8"	20-1/4"	28-1/4"				14700	3000	24
CL2510-S	2.5" X 10"	20-1/4"	30-1/4"				14700	3000	25
CL2512-S	2.5" X 12"	22-1/4"	34-1/4"				14700	3000	27
CL2514-S	2.5" X 14"	24-1/4"	38-1/4"				14700	3000	29
CL2516-S	2.5" X 16"	26-1/4"	42-1/4"				14700	3000	32
CL2518-S	2.5" X 18"	28-1/4"	46-1/4"				14700	3000	34
CL2520-S	2.5" X 20"	30-1/4"	50-1/4"				14700	3000	36
CL2524-S	2.5" X 24"	34-1/4"	58-1/4"				14000	2800	40
CL2528-S	2.5" X 28"	38-1/4"	66-1/4"				10800	2200	45
CL2530-S	2.5" X 30"	40-1/4"	70-1/4"				9600	1900	47
CL2532-S	2.5" X 32"	42-1/4"	74-1/4"				8600	1700	49
CL2534-S	2.5" X 34"	44-1/4"	78-1/4"				7700	1500	52
CL2536-S	2.5" X 36"	46-1/4"	82-1/4"				7000	1400	54
CL2540-S	2.5" X 40"	50-1/4"	90-1/4"				5800	1100	58
CL2548-S	2.5" X 48"	58-1/4"	106-1/4"	4200	800	67			
CL3004-S	3" X 4"	14-1/4"	18-1/4"	1-1/2"	1"	SAE-08	21200	3000	22
CL3006-S	3" X 6"	16-1/4"	22-1/4"				21200	3000	24
CL3008-S	3" X 8"	20-1/4"	28-1/4"				21200	3000	27
CL3010-S	3" X 10"	20-1/4"	30-1/4"				21200	3000	29
CL3012-S	3" X 12"	22-1/4"	34-1/4"				21200	3000	31
CL3014-S	3" X 14"	24-1/4"	38-1/4"				21200	3000	34
CL3016-S	3" X 16"	26-1/4"	42-1/4"				21200	3000	36
CL3018-S	3" X 18"	28-1/4"	46-1/4"				21200	3000	39
CL3020-S	3" X 20"	30-1/4"	50-1/4"				18800	2600	41
CL3024-S	3" X 24"	34-1/4"	58-1/4"				14000	1900	46
CL3028-S	3" X 28"	38-1/4"	66-1/4"				10800	1500	51
CL3030-S	3" X 30"	40-1/4"	70-1/4"				9600	1300	53
CL3032-S	3" X 32"	42-1/4"	74-1/4"				8600	1200	56
CL3034-S	3" X 34"	44-1/4"	78-1/4"				7700	1100	58
CL3036-S	3" X 36"	46-1/4"	82-1/4"				7000	900	61
CL3504-S	3.5" X 4"	14-1/4"	18-1/4"				1-3/4"	1"	SAE-08
CL3506-S	3.5" X 6"	16-1/4"	22-1/4"	28800	3000	30			
CL3508-S	3.5" X 8"	20-1/4"	28-1/4"	28800	3000	35			
CL3510-S	3.5" X 10"	20-1/4"	30-1/4"	28800	3000	36			
CL3512-S	3.5" X 12"	22-1/4"	34-1/4"	28800	3000	39			
CL3514-S	3.5" X 14"	24-1/4"	38-1/4"	28800	3000	42			
CL3516-S	3.5" X 16"	26-1/4"	42-1/4"	28800	3000	46			
CL3518-S	3.5" X 18"	28-1/4"	46-1/4"	28800	3000	49			
CL3520-S	3.5" X 20"	30-1/4"	50-1/4"	28800	3000	52			
CL3524-S	3.5" X 24"	34-1/4"	58-1/4"	26000	2700	58			
CL3528-S	3.5" X 28"	38-1/4"	66-1/4"	20100	2000	64			
CL3530-S	3.5" X 30"	40-1/4"	70-1/4"	17900	1800	67			
CL3532-S	3.5" X 32"	42-1/4"	74-1/4"	16000	1600	70			
CL3534-S	3.5" X 34"	44-1/4"	78-1/4"	14400	1500	73			
CL3536-S	3.5" X 36"	46-1/4"	82-1/4"	13000	1300	76			

COLUMN LOAD IS THE MAXIMUM PUSHING LOAD SUGGESTED USING A MINIMUM SAFETY FACTOR OF 2 AND BASED ON A PIN TO PIN MOUNTING CALCULATION.

HYDRO CUSTOM IS NOT RESPONSIBLE FOR INCORRECT RESULTS OBTAINED WITH FIGURES IN THIS DOCUMENT. INFORMATION IS FOR REFERENCE ONLY. NO OTHER CONDITIONS ARE EXPRESSED OR IMPLIED.



MODEL CODE	BORE X STROKE	DIMENSIONS		ROD DIAMETER	PIN SIZE	PORT SIZE*	COLUMN LOADS (LBS)	PRESSURE (PSI)	WEIGHT (LBS)
		RETRACTED	EXTENDED						
CL4004-S	4" X 4"	14-1/4"	18-1/4"	2"	1"	SAE-08	37600	3000	33
CL4006-S	4" X 6"	16-1/4"	22-1/4"				37600	3000	37
CL4008-S	4" X 8"	20-1/4"	28-1/4"				37600	3000	42
CL4010-S	4" X 10"	20-1/4"	30-1/4"				37600	3000	44
CL4012-S	4" X 12"	22-1/4"	34-1/4"				37600	3000	48
CL4014-S	4" X 14"	24-1/4"	38-1/4"				37600	3000	52
CL4016-S	4" X 16"	26-1/4"	42-1/4"				37600	3000	55
CL4018-S	4" X 18"	28-1/4"	46-1/4"				37600	3000	59
CL4020-S	4" X 20"	30-1/4"	50-1/4"				37600	3000	63
CL4024-S	4" X 24"	34-1/4"	58-1/4"				37600	3000	70
CL4028-S	4" X 28"	38-1/4"	66-1/4"				34300	2700	77
CL4030-S	4" X 30"	40-1/4"	70-1/4"				30500	2400	81
CL4032-S	4" X 32"	42-1/4"	74-1/4"				27300	2100	85
CL4034-S	4" X 34"	44-1/4"	78-1/4"				24600	1900	89
CL4036-S	4" X 36"	46-1/4"	82-1/4"				22200	1700	92
CL5004-S	5" X 4"	17"	21"				2-1/2"	1-1/2"	SAE-12
CL5006-S	5" X 6"	19"	25"	58900	3000	69			
CL5008-S	5" X 8"	21"	29"	58900	3000	74			
CL5010-S	5" X 10"	23"	33"	58900	3000	79			
CL5012-S	5" X 12"	25"	37"	58900	3000	84			
CL5014-S	5" X 14"	27"	41"	58900	3000	89			
CL5016-S	5" X 16"	29"	45"	58900	3000	95			
CL5018-S	5" X 18"	31"	49"	58900	3000	100			
CL5020-S	5" X 20"	33"	53"	58900	3000	105			
CL5024-S	5" X 24"	37"	61"	58900	3000	115			
CL5028-S	5" X 28"	41"	69"	58900	3000	125			
CL5030-S	5" X 30"	43"	73"	58900	3000	130			
CL5032-S	5" X 32"	45"	77"	58900	3000	135			
CL5034-S	5" X 34"	47"	81"	56100	2800	141			
CL5036-S	5" X 36"	49"	85"	50900	2500	146			
CL5040-S	5" X 40"	53"	93"	42500	2100	156			
CL5048-S	5" X 48"	61"	109"	30900	1500	176			

COLUMN LOAD IS THE MAXIMUM PUSHING LOAD SUGGESTED USING A MINIMUM SAFETY FACTOR OF 2 AND BASED ON A PIN TO PIN MOUNTING CALCULATION.

HYDRAULIC CYLINDERS

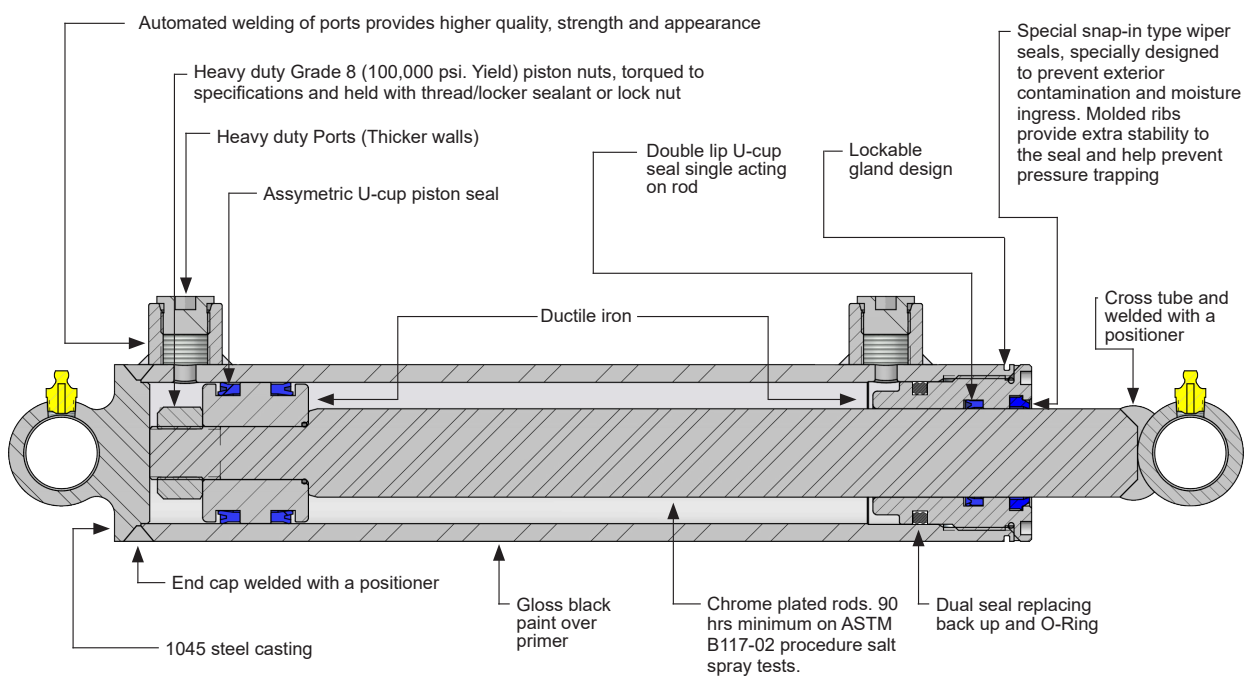

SEAL TEMPERATURE RANGE : -30°C / +100°C (-22°F / +212°F)
 SEAL MAXIMUM SPEED : 3 FT / SEC

ALL SEALS ARE TOP GRADE/FIRST QUALITY NORTH AMERICAN MADE
 ALL COMPONENTS ARE CNC MACHINED FOR HIGHER ACCURACY AND CONFORMITY
 QUALITY CONTROLLED IN CHINA BY QUALIFIED CANADIAN TECHNICIANS
 100% TESTED. ALL CYLINDERS ARE SUBMITTED TO STATIC AND DYNAMIC PRESSURE TESTS TO RECOMMENDED SPECIFICATIONS

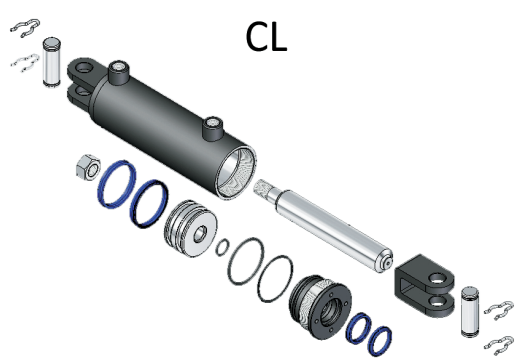
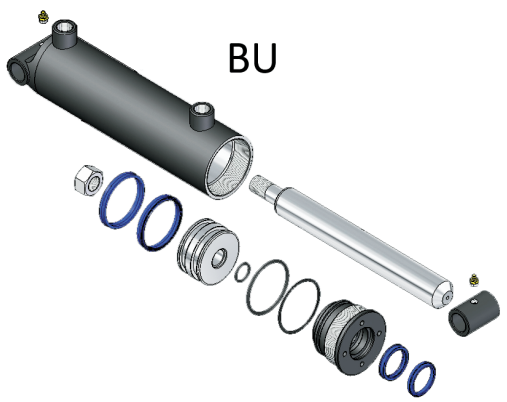

HYDRO CUSTOM IS NOT RESPONSIBLE FOR INCORRECT RESULTS OBTAINED WITH FIGURES IN THIS DOCUMENT. INFORMATION IS FOR REFERENCE ONLY. NO OTHER CONDITIONS ARE EXPRESSED OR IMPLIED.

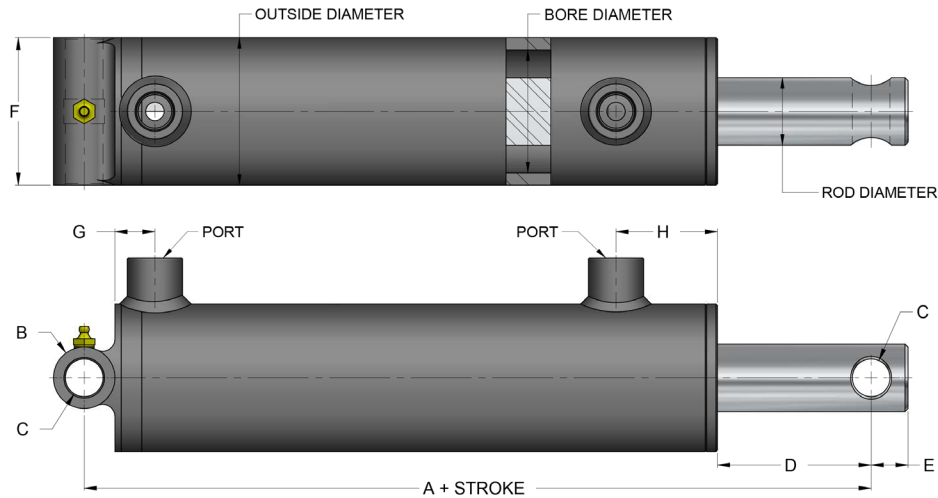

MODEL CODE	CYLINDER BORE	OUTSIDE DIAMETER	ROD DIAMETER	A	B	C	D	E*	F	G	H	PORT SIZE*
WT3-15XX-S	1.50	1.875	1.00	7.00	1.25	0.64	2.43	0.62	2.00	0.81	1.87	SAE-08
WT3-20XX-S	2.00	2.375	1.25	8.00	1.25	0.76	3.37	0.75	2.50	0.81	1.87	SAE-08
WT3-25XX-S	2.50	2.875	1.375	8.00	1.25	0.76	3.12	0.75	3.00	0.81	2.06	SAE-08
WT3-30XX-S	3.00	3.50	1.50	8.00	1.50	1.01	2.56	1.00	3.50	0.81	2.18	SAE-08
WT3-35XX-S	3.50	4.00	1.75	8.00	1.50	1.01	2.43	1.00	4.00	0.81	2.18	SAE-08
WT3-40XX-S	4.00	4.50	2.00	9.00	2.00	1.26	2.43	1.25	4.50	0.81	2.18	SAE-08

FOR 2" TO 4" BORE, 8" STROKE : A = 12.25", E = 5.12"
 * NPT PORTS ARE ALSO AVAILABLE FROM 1.5" TO 4" BORE CYLINDERS
 MAXIMUM RETRACTED WORKING PRESSURE : 3000 PSI
 MAXIMUM EXTENDED WORKING PRESSURE : SEE TABLE
 RETRACTED AND STROKE TOLERANCE ± 1/8"

MODEL CODE	BORE X STROKE	DIMENSIONS		ROD DIAMETER	PIN SIZE	PORT SIZE	COLUMN LOADS (LBS)	PRESSURE (PSI)	WEIGHT (LBS)
		RETRACTED	EXTENDED						
WT3-1504-S	1.5" X 4"	11"	15"	1"	5/8"	SAE-06	5300	3000	7
WT3-1506-S	1.5" X 6"	13"	19"				5300	3000	8
WT3-1508-S	1.5" X 8"	15"	23"				5300	3000	9
WT3-1510-S	1.5" X 10"	17"	27"				5300	3000	11
WT3-1512-S	1.5" X 12"	19"	31"				5300	3000	12
WT3-1514-S	1.5" X 14"	21"	35"				5300	3000	13
WT3-1516-S	1.5" X 16"	23"	39"				5300	3000	14
WT3-2004-S	2" X 4"	12"	16"	1-1/4"	3/4"	SAE-08	9400	3000	11
WT3-2006-S	2" X 6"	14"	20"				9400	3000	12
WT3-2008-S	2" X 8"	16"	24"				9400	3000	14
WT3-2010-S	2" X 10"	18"	28"				9400	3000	16
WT3-2012-S	2" X 12"	20"	32"				9400	3000	17
WT3-2014-S	2" X 14"	22"	36"				9400	3000	19
WT3-2016-S	2" X 16"	24"	40"				9400	3000	21
WT3-2018-S	2" X 18"	26"	44"				9400	3000	22
WT3-2020-S	2" X 20"	28"	48"				9400	3000	24
WT3-2024-S	2" X 24"	32"	56"				7300	2300	27
WT3-2028-S	2" X 28"	36"	64"				5600	1700	31
WT3-2030-S	2" X 30"	38"	68"				4900	1500	33
WT3-2032-S	2" X 32"	40"	72"				4400	1400	34
WT3-2036-S	2" X 36"	44"	80"				3500	1100	38
WT3-2040-S	2" X 40"	48"	88"				2900	900	41
WT3-2042-S	2" X 42"	50"	92"				2700	800	43
WT3-2048-S	2" X 48"	56"	104"				2100	600	48
WT3-2060-S	2" X 60"	68"	128"	1400	400	58			
WT3-2072-S	2" X 72"	80"	152"	900	300	68			

COLUMN LOAD IS THE MAXIMUM PUSHING LOAD SUGGESTED USING A MINIMUM SAFETY FACTOR OF 2 AND BASED ON A PIN TO PIN MOUNTING CALCULATION.

HYDRO CUSTOM IS NOT RESPONSIBLE FOR INCORRECT RESULTS OBTAINED WITH FIGURES IN THIS DOCUMENT. INFORMATION IS FOR REFERENCE ONLY. NO OTHER CONDITIONS ARE EXPRESSED OR IMPLIED.



MODEL CODE	BORE X STROKE	DIMENSIONS		ROD DIAMETER	PIN SIZE	PORT SIZE	COLUMN LOADS (LBS)	PRESSURE (PSI)	WEIGHT (LBS)			
		RETRACTED	EXTENDED									
WT3-2504-S	2.5" X 4"	12"	16"	1-3/8"	3/4"	SAE-08	14700	3000	14			
WT3-2506-S	2.5" X 6"	14"	20"				14700	3000	16			
WT3-2508-S	2.5" X 8"	16"	24"				14700	3000	18			
WT3-2510-S	2.5" X 10"	18"	28"				14700	3000	20			
WT3-2512-S	2.5" X 12"	20"	32"				14700	3000	22			
WT3-2514-S	2.5" X 14"	22"	36"				14700	3000	24			
WT3-2516-S	2.5" X 16"	24"	40"				14700	3000	26			
WT3-2518-S	2.5" X 18"	26"	44"				14700	3000	28			
WT3-2520-S	2.5" X 20"	28"	48"				14600	2900	30			
WT3-2524-S	2.5" X 24"	32"	56"				10700	2100	35			
WT3-2528-S	2.5" X 28"	36"	64"				8200	1600	39			
WT3-2530-S	2.5" X 30"	38"	68"				7200	1400	41			
WT3-2532-S	2.5" X 32"	40"	72"				6500	1300	43			
WT3-2536-S	2.5" X 36"	44"	80"				5200	1000	47			
WT3-2540-S	2.5" X 40"	48"	88"				4300	800	51			
WT3-2542-S	2.5" X 42"	50"	92"				3900	800	53			
WT3-2548-S	2.5" X 48"	56"	104"				3100	600	60			
WT3-2560-S	2.5" X 60"	68"	128"				2000	400	72			
WT3-3006-S	3" X 6"	14"	20"				1-1/2"	1"	SAE-08	21200	3000	21
WT3-3008-S	3" X 8"	16"	24"							21200	3000	24
WT3-3010-S	3" X 10"	18"	28"	21200	3000	26						
WT3-3012-S	3" X 12"	20"	32"	21200	3000	28						
WT3-3014-S	3" X 14"	22"	36"	21200	3000	31						
WT3-3016-S	3" X 16"	24"	40"	21200	3000	33						
WT3-3018-S	3" X 18"	26"	44"	21200	3000	36						
WT3-3020-S	3" X 20"	28"	48"	20700	2900	38						
WT3-3024-S	3" X 24"	32"	56"	15200	2100	43						
WT3-3028-S	3" X 28"	36"	64"	11600	1600	48						
WT3-3030-S	3" X 30"	38"	68"	10300	1400	51						
WT3-3032-S	3" X 32"	40"	72"	9200	1300	53						
WT3-3036-S	3" X 36"	44"	80"	7400	1000	58						
WT3-3040-S	3" X 40"	48"	88"	6100	800	63						
WT3-3042-S	3" X 42"	50"	92"	5600	700	65						
WT3-3048-S	3" X 48"	56"	104"	4400	600	73						
WT3-3060-S	3" X 60"	68"	128"	2900	400	87						

COLUMN LOAD IS THE MAXIMUM PUSHING LOAD SUGGESTED USING A MINIMUM SAFETY FACTOR OF 2 AND BASED ON A PIN TO PIN MOUNTING CALCULATION.



MODEL CODE	BORE X STROKE	DIMENSIONS		ROD DIAMETER	PIN SIZE	PORT SIZE	COLUMN LOADS (LBS)	PRESSURE (PSI)	WEIGHT (LBS)			
		RETRACTED	EXTENDED									
WT3-2504-S	2.5" X 4"	12"	16"	1-3/8"	3/4"	SAE-08	14700	3000	14			
WT3-2506-S	2.5" X 6"	14"	20"				14700	3000	16			
WT3-2508-S	2.5" X 8"	16"	24"				14700	3000	18			
WT3-2510-S	2.5" X 10"	18"	28"				14700	3000	20			
WT3-2512-S	2.5" X 12"	20"	32"				14700	3000	22			
WT3-2514-S	2.5" X 14"	22"	36"				14700	3000	24			
WT3-2516-S	2.5" X 16"	24"	40"				14700	3000	26			
WT3-2518-S	2.5" X 18"	26"	44"				14700	3000	28			
WT3-2520-S	2.5" X 20"	28"	48"				14600	2900	30			
WT3-2524-S	2.5" X 24"	32"	56"				10700	2100	35			
WT3-2528-S	2.5" X 28"	36"	64"				8200	1600	39			
WT3-2530-S	2.5" X 30"	38"	68"				7200	1400	41			
WT3-2532-S	2.5" X 32"	40"	72"				6500	1300	43			
WT3-2536-S	2.5" X 36"	44"	80"				5200	1000	47			
WT3-2540-S	2.5" X 40"	48"	88"				4300	800	51			
WT3-2542-S	2.5" X 42"	50"	92"				3900	800	53			
WT3-2548-S	2.5" X 48"	56"	104"				3100	600	60			
WT3-2560-S	2.5" X 60"	68"	128"				2000	400	72			
WT3-3006-S	3" X 6"	14"	20"				1-1/2"	1"	SAE-08	21200	3000	21
WT3-3008-S	3" X 8"	16"	24"							21200	3000	24
WT3-3010-S	3" X 10"	18"	28"	21200	3000	26						
WT3-3012-S	3" X 12"	20"	32"	21200	3000	28						
WT3-3014-S	3" X 14"	22"	36"	21200	3000	31						
WT3-3016-S	3" X 16"	24"	40"	21200	3000	33						
WT3-3018-S	3" X 18"	26"	44"	21200	3000	36						
WT3-3020-S	3" X 20"	28"	48"	20700	2900	38						
WT3-3024-S	3" X 24"	32"	56"	15200	2100	43						
WT3-3028-S	3" X 28"	36"	64"	11600	1600	48						
WT3-3030-S	3" X 30"	38"	68"	10300	1400	51						
WT3-3032-S	3" X 32"	40"	72"	9200	1300	53						
WT3-3036-S	3" X 36"	44"	80"	7400	1000	58						
WT3-3040-S	3" X 40"	48"	88"	6100	800	63						
WT3-3042-S	3" X 42"	50"	92"	5600	700	65						
WT3-3048-S	3" X 48"	56"	104"	4400	600	73						
WT3-3060-S	3" X 60"	68"	128"	2900	400	87						

HYDRAULIC CYLINDERS

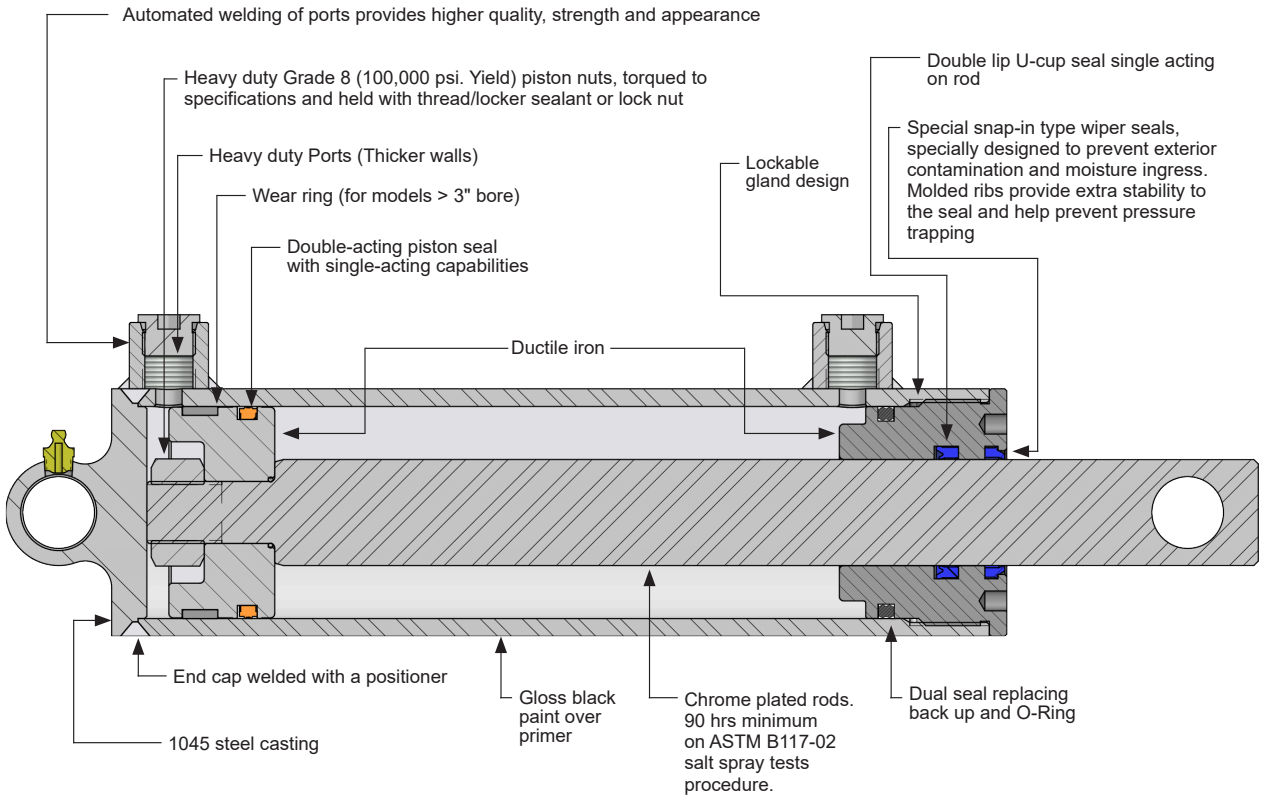

SEAL TEMPERATURE RANGE : -30°C / +100°C (-22°F / +212°F)
 SEAL MAXIMUM SPEED : 3 FT / SEC

ALL SEALS ARE TOP GRADE/FIRST QUALITY NORTH AMERICAN MADE
 ALL COMPONENTS ARE CNC MACHINED FOR HIGHER ACCURACY AND CONFORMITY
 QUALITY CONTROLLED IN CHINA BY QUALIFIED CANADIAN TECHNICIANS
 100% TESTED. ALL CYLINDERS ARE SUBMITTED TO STATIC AND DYNAMIC PRESSURE TESTS TO RECOMMENDED SPECIFICATIONS

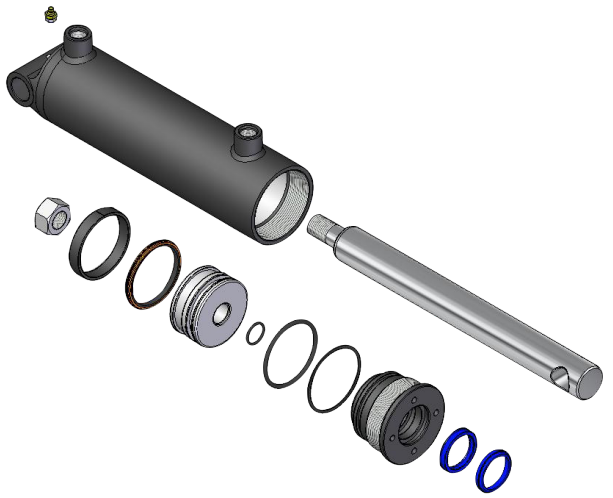

HYDRO CUSTOM IS NOT RESPONSIBLE FOR INCORRECT RESULTS OBTAINED WITH FIGURES IN THIS DOCUMENT. INFORMATION IS FOR REFERENCE ONLY. NO OTHER CONDITIONS ARE EXPRESSED OR IMPLIED.

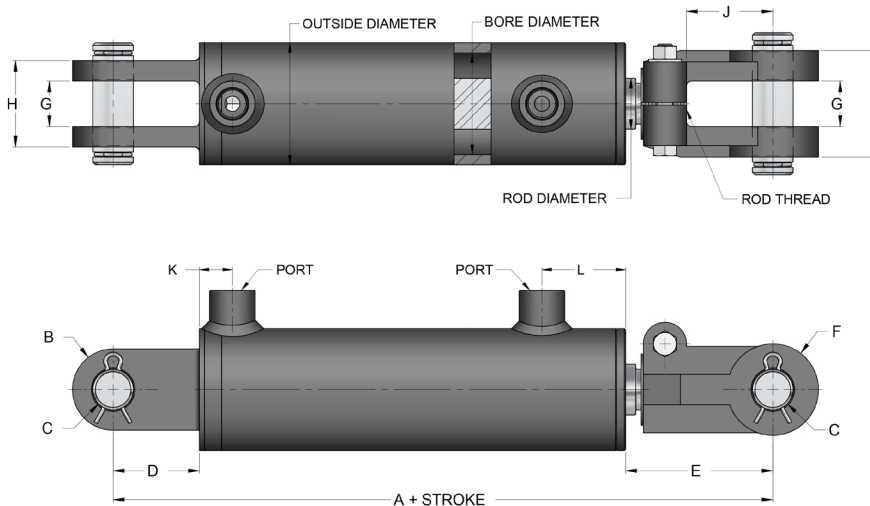

MODEL CODE	CYLINDER BORE	OUTSIDE DIAMETER	ROD DIAMETER	ROD THREAD	*A	B	C	D	*E	F	G	H	I	J	K	L	PORT SIZE*
TCL15XX-S	1.50	1.875	1.00	7/8-14 UNF	10.25	1.5	0.76	1.62	4.50	1.6	0.87	2.44	2.00	1.62	0.93	1.87	SAE-06
TCL20XX-S	2.00	2.375	1.12	1 1/8-12 UNF	10.25	2.0	1.01	2.00	3.62	2.0	1.14	2.44	2.50	2.12	0.81	2.06	SAE-08
TCL25XX-S	2.50	2.875	1.25	1 1/8-12 UNF	10.25	2.0	1.01	2.00	3.62	2.0	1.14	2.72	2.72	2.12	0.81	2.06	SAE-08
TCL30XX-S	3.00	3.50	1.50	1 1/4-12 UNF	10.25	2.0	1.01	2.00	3.62	2.0	1.14	2.72	2.72	2.12	0.87	2.18	SAE-08
TCL35XX-S	3.50	4.00	1.75	1 1/2-12 UNF	10.25	2.0	1.01	2.00	3.62	2.0	1.14	2.72	2.72	2.12	0.93	2.18	SAE-08
TCL40XX-S	4.00	4.50	2.00	1 1/2-12 UNF	10.25	2.0	1.01	2.12	3.62	2.0	1.14	2.72	2.95	2.12	1.00	2.18	SAE-08

FOR 2" TO 4" BORE, 8" STROKE : A = 12.25", E = 5.12"
 * NPT PORTS ARE ALSO AVAILABLE FROM 1.5" TO 4" BORE CYLINDERS
 MAXIMUM RETRACTED WORKING PRESSURE : 3000 PSI
 MAXIMUM EXTENDED WORKING PRESSURE : SEE TABLE
 RETRACTED AND STROKE TOLERANCE ± 1/8"

MODEL CODE	BORE X STROKE	DIMENSIONS		ROD DIAMETER	PIN SIZE	PORT SIZE*	COLUMN LOADS (LBS)	PRESSURE (PSI)	WEIGHT (LBS)
		RETRACTED	EXTENDED						
TCL1504-S	1.5" X 4"	14-1/4"	18-1/4"	1"	3/4"	SAE-06	5300	3000	10
TCL1506-S	1.5" X 6"	16-1/4"	22-1/4"				5300	3000	11
TCL1508-S	1.5" X 8"	18-1/4"	26-1/4"				5300	3000	12
TCL1508-ASAE*	1.5" X 8"	20-1/4"	28-1/4"				5300	3000	13
TCL1510-S	1.5" X 10"	20-1/4"	30-1/4"				5300	3000	13
TCL1512-S	1.5" X 12"	22-1/4"	34-1/4"				5300	3000	15
TCL1514-S	1.5" X 14"	24-1/4"	38-1/4"				5300	3000	16
TCL1516-S	1.5" X 16"	26-1/4"	42-1/4"				5200	2900	17
TCL1518-S	1.5" X 18"	28-1/4"	46-1/4"				4400	2400	18
TCL1520-S	1.5" X 20"	30-1/4"	50-1/4"				3700	2100	20
TCL1524-S	1.5" X 24"	34-1/4"	58-1/4"				2700	1500	22
TCL1528-S	1.5" X 28"	38-1/4"	66-1/4"				2100	1200	25
TCL1530-S	1.5" X 30"	40-1/4"	70-1/4"				1900	1000	26
TCL1532-S	1.5" X 32"	42-1/4"	74-1/4"				1700	900	27
TCL1534-S	1.5" X 34"	44-1/4"	78-1/4"				1500	800	28
TCL1536-S	1.5" X 36"	46-1/4"	82-1/4"				1300	700	29

* ASAE = AMERICAN SOCIETY OF AGRICULTURE ENGINEERS
 DESIGNATES AN INDUSTRY MOUNTING STANDARD FOR 8" AND 16" STROKE CYLINDERS

HYDRO CUSTOM IS NOT RESPONSIBLE FOR INCORRECT RESULTS OBTAINED WITH FIGURES IN THIS DOCUMENT. INFORMATION IS FOR REFERENCE ONLY. NO OTHER CONDITIONS ARE EXPRESSED OR IMPLIED.

HYDRAULIC CYLINDERS



MODEL CODE	BORE X STROKE	DIMENSIONS		ROD DIAMETER	PIN SIZE	PORT SIZE*	COLUMN LOADS (LBS)	PRESSURE (PSI)	WEIGHT (LBS)
		RETRACTED	EXTENDED						
TCL2004-S	2" X 4"	14-1/4"	18-1/4"	1-1/8"	1"	SAE-08	9400	3000	16
TCL2006-S	2" X 6"	16-1/4"	22-1/4"				9400	3000	17
TCL2008-S	2" X 8"	18-1/4"	26-1/4"				9400	3000	19
TCL2008-ASAE*	2" X 8"	20-1/4"	28-1/4"				9400	3000	19
TCL2010-S	2" X 10"	20-1/4"	30-1/4"				9400	3000	20
TCL2012-S	2" X 12"	22-1/4"	34-1/4"				9400	3000	22
TCL2014-S	2" X 14"	24-1/4"	38-1/4"				9400	3000	23
TCL2016-S	2" X 16"	26-1/4"	42-1/4"				8400	2600	25
TCL2018-S	2" X 18"	28-1/4"	46-1/4"				7000	2200	27
TCL2020-S	2" X 20"	30-1/4"	50-1/4"				5900	1900	28
TCL2024-S	2" X 24"	34-1/4"	58-1/4"				4400	1400	31
TCL2030-S	2" X 30"	40-1/4"	70-1/4"				3000	900	36
TCL2036-S	2" X 36"	46-1/4"	82-1/4"				2200	700	41
TCL2504-S	2.5" X 4"	14-1/4"	18-1/4"				1-1/4"	1"	SAE-08
TCL2506-S	2.5" X 6"	16-1/4"	22-1/4"	14700	3000	20			
TCL2508-S	2.5" X 8"	18-1/4"	26-1/4"	14700	3000	22			
TCL2508-ASAE*	2.5" X 8"	20-1/4"	28-1/4"	14700	3000	23			
TCL2510-S	2.5" X 10"	20-1/4"	30-1/4"	14700	3000	24			
TCL2512-S	2.5" X 12"	22-1/4"	34-1/4"	14700	3000	26			
TCL2514-S	2.5" X 14"	24-1/4"	38-1/4"	14700	3000	28			
TCL2516-S	2.5" X 16"	26-1/4"	42-1/4"	12800	2600	30			
TCL2518-S	2.5" X 18"	28-1/4"	46-1/4"	10700	2100	32			
TCL2520-S	2.5" X 20"	30-1/4"	50-1/4"	9100	1800	34			
TCL2524-S	2.5" X 24"	34-1/4"	58-1/4"	6700	1300	38			
TCL2530-S	2.5" X 30"	40-1/4"	70-1/4"	4600	900	44			
TCL2536-S	2.5" X 36"	46-1/4"	82-1/4"	3400	600	49			
TCL3004-S	3" X 4"	14-1/4"	18-1/4"	1-1/2"	1"	SAE-08			
TCL3006-S	3" X 6"	16-1/4"	22-1/4"				21200	3000	26
TCL3008-S	3" X 8"	18-1/4"	26-1/4"				21200	3000	29
TCL3008-ASAE*	3" X 8"	20-1/4"	28-1/4"				21200	3000	29
TCL3010-S	3" X 10"	20-1/4"	30-1/4"				21200	3000	31
TCL3012-S	3" X 12"	22-1/4"	34-1/4"				21200	3000	33
TCL3014-S	3" X 14"	24-1/4"	38-1/4"				21200	3000	36
TCL3016-S	3" X 16"	26-1/4"	42-1/4"				21200	3000	38
TCL3016-ASAE*	3" X 16"	31-1/2"	47-1/2"				21200	3000	38
TCL3018-S	3" X 18"	28-1/4"	46-1/4"				21200	3000	41
TCL3020-S	3" X 20"	30-1/4"	50-1/4"				18800	2600	43
TCL3024-S	3" X 24"	34-1/4"	58-1/4"				14000	1900	48
TCL3030-S	3" X 30"	40-1/4"	70-1/4"				9600	1300	56
TCL3036-S	3" X 36"	46-1/4"	82-1/4"				7000	900	63

COLUMN LOAD IS THE MAXIMUM PUSHING LOAD SUGGESTED USING A MINIMUM SAFETY FACTOR OF 2 AND BASED ON A PIN TO PIN MOUNTING CALCULATION.

* ASAE = AMERICAN SOCIETY OF AGRICULTURE ENGINEERS
DESIGNATES AN INDUSTRY MOUNTING STANDARD FOR 8" AND 16" STROKE CYLINDERS

HYDRO CUSTOM IS NOT RESPONSIBLE FOR INCORRECT RESULTS OBTAINED WITH FIGURES IN THIS DOCUMENT. INFORMATION IS FOR REFERENCE ONLY. NO OTHER CONDITIONS ARE EXPRESSED OR IMPLIED.



MODEL CODE	BORE X STROKE	DIMENSIONS		ROD DIAMETER	PIN SIZE	PORT SIZE*	COLUMN LOADS (LBS)	PRESSURE (PSI)	WEIGHT (LBS)			
		RETRACTED	EXTENDED									
TCL3504-S	3.5" X 4"	14-1/4"	18-1/4"	1-3/4"	1"	SAE-08	28800	3000	29			
TCL3506-S	3.5" X 6"	16-1/4"	22-1/4"				28800	3000	32			
TCL3508-S	3.5" X 8"	18-1/4"	26-1/4"				28800	3000	35			
TCL3508-ASAE*	3.5" X 8"	20-1/4"	28-1/4"				28800	3000	36			
TCL3510-S	3.5" X 10"	20-1/4"	30-1/4"				28800	3000	38			
TCL3512-S	3.5" X 12"	22-1/4"	34-1/4"				28800	3000	41			
TCL3514-S	3.5" X 14"	24-1/4"	38-1/4"				28800	3000	44			
TCL3516-S	3.5" X 16"	26-1/4"	42-1/4"				28800	3000	47			
TCL3516-ASAE*	3.5" X 16"	31-1/2"	47-1/2"				28800	3000	47			
TCL3518-S	3.5" X 18"	28-1/4"	46-1/4"				28800	3000	50			
TCL3520-S	3.5" X 20"	30-1/4"	50-1/4"				28800	3000	53			
TCL3524-S	3.5" X 24"	34-1/4"	58-1/4"				26000	2700	59			
TCL3530-S	3.5" X 30"	40-1/4"	70-1/4"				17900	1800	68			
TCL3536-S	3.5" X 36"	46-1/4"	82-1/4"				13000	1300	77			
TCL4004-S	4" X 4"	14-1/4"	18-1/4"				2"	1"	SAE-08	37600	3000	35
TCL4006-S	4" X 6"	16-1/4"	22-1/4"							37600	3000	38
TCL4008-S	4" X 8"	18-1/4"	26-1/4"	37600	3000	42						
TCL4008-ASAE*	4" X 8"	20-1/4"	28-1/4"	37600	3000	43						
TCL4010-S	4" X 10"	20-1/4"	30-1/4"	37600	3000	46						
TCL4012-S	4" X 12"	22-1/4"	34-1/4"	37600	3000	49						
TCL4014-S	4" X 14"	24-1/4"	38-1/4"	37600	3000	53						
TCL4016-S	4" X 16"	26-1/4"	42-1/4"	37600	3000	57						
TCL4016-ASAE*	4" X 16"	31-1/2"	47-1/2"	37600	3000	57						
TCL4018-S	4" X 18"	28-1/4"	46-1/4"	37600	3000	60						
TCL4020-S	4" X 20"	30-1/4"	50-1/4"	37600	3000	64						
TCL4024-S	4" X 24"	34-1/4"	58-1/4"	37600	3000	71						
TCL4030-S	4" X 30"	40-1/4"	70-1/4"	30500	2400	82						
TCL4036-S	4" X 36"	46-1/4"	82-1/4"	22200	1700	93						

COLUMN LOAD IS THE MAXIMUM PUSHING LOAD SUGGESTED USING A MINIMUM SAFETY FACTOR OF 2 AND BASED ON A PIN TO PIN MOUNTING CALCULATION.

* ASAE = AMERICAN SOCIETY OF AGRICULTURE ENGINEERS DESIGNATES AN INDUSTRY MOUNTING STANDARD FOR 8" AND 16" STROKE CYLINDERS

HYDRAULIC CYLINDERS

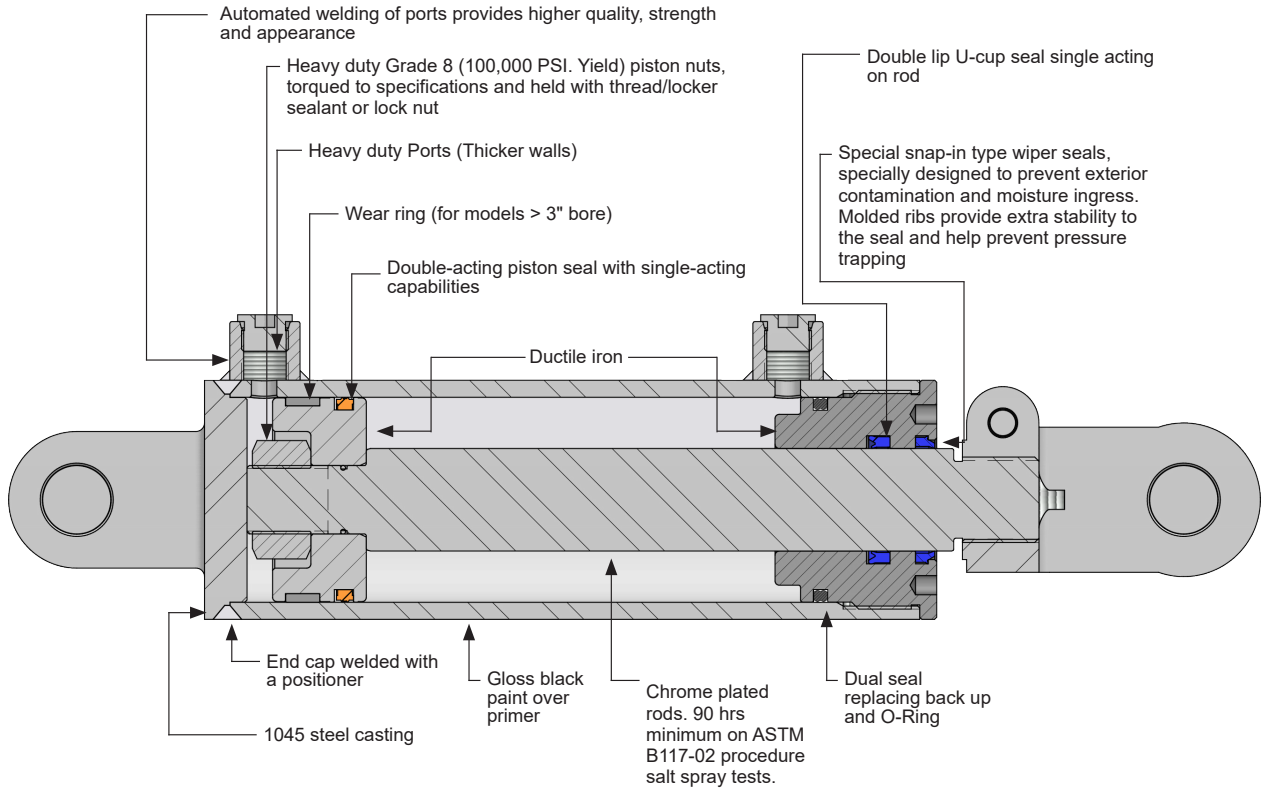

SEAL TEMPERATURE RANGE : -30°C / +100°C (-22°F / +212°F)
 SEAL MAXIMUM SPEED : 3 FT / SEC

- All seals are top grade/first quality North American made
- All components are CNC machined for higher accuracy and conformity
- Quality controlled in China by qualified Canadian technicians
- 100% tested. All cylinders are submitted to static and dynamic pressure tests to recommended specifications

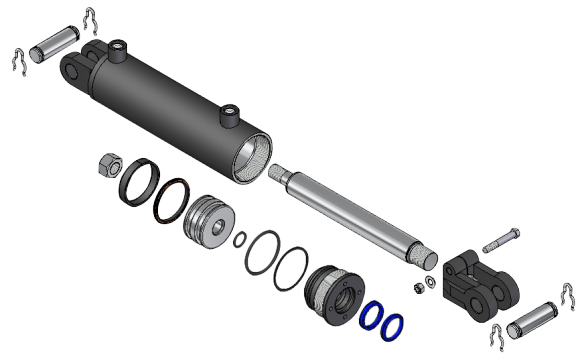

HYDRO CUSTOM IS NOT RESPONSIBLE FOR INCORRECT RESULTS OBTAINED WITH FIGURES IN THIS DOCUMENT. INFORMATION IS FOR REFERENCE ONLY. NO OTHER CONDITIONS ARE EXPRESSED OR IMPLIED.

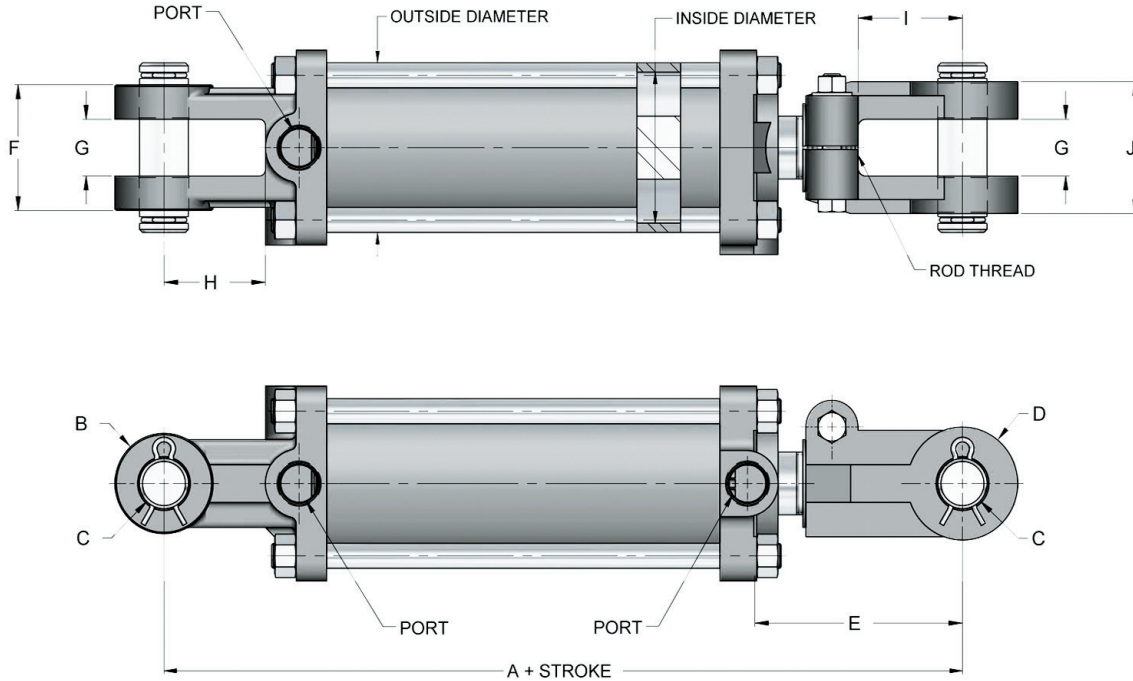

MODEL CODE	CYLINDER BORE	OUTSIDE DIAMETER	ROD THREAD	A ²	B	C ³	D ⁴	E ⁵	F	G	H	I	J ⁴	PORT SIZE
TR2.5-20XX-S	2.00	2.38	1 1/8-12 UNF	10.25	2.00	1.01	2.00	4.17	2.44	1.14	2.00	2.12	2.50	SAE-08
TR2.5-25XX-S	2.50	2.89	1 1/8-12 UNF	10.25	2.00	1.01	2.00	4.17	2.44	1.14	2.00	2.12	2.50	SAE-08
TR2.5-30XX-S	3.00	3.39	1 1/4-12 UNF	10.25	2.00	1.01	2.00	4.14	2.72	1.14	2.00	2.12	2.72	SAE-08
TR2.5-35XX-S	3.50	3.87	1 1/4-12 UNF	10.25	2.00	1.01	2.00	4.09	2.72	1.14	2.00	2.12	2.72	SAE-08
TR2.5-40XX-S	4.00	4.50	1 1/4-12 UNF	10.25	2.00	1.01	2.00	3.82	2.72	1.14	2.12	2.12	2.72	SAE-08

- FOR TR2.5-2518 TO TR2.5-2536: ROD THREAD= 1.250-12 UNF
 - FOR 8.00" ASAE STROKE: A= 12.25"
FOR 16.00" ASAE STROKE: A= 15.50"
 - FOR 16.00" ASAE STROKE: C= 1.26"
 - FOR TR2.5-4016-ASAE TO TR2.5-4036: D= 2.50" J=2.75" ROD THREAD= 1.500-12 UNF
 - FOR 8.00" ASAE STROKE: E= 5.75" (2.00" TO 3.00" BORE) E=5.62" (3.50" BORE) E=5.56" (4.00" BORE)
FOR 16.00" ASAE STROKE: E= 9.00" (2.00" TO 3.00" BORE) E=8.87" (3.50" BORE) E=8.81" (4.00" BORE)
- MAXIMUM RETRACTED WORKING PRESSURE= 2500 psi
 MAXIMUM EXTENDED WORKING PRESSURE= SEE TABLE
 FOR ALL CYLINDER, RETRACTED TOLERANCE ± 1/8"

MODEL CODE	BORE X STROKE	DIMENSIONS		ROD DIAMETER	PIN SIZE	PORT SIZE	COLUMN LOADS (LBS)	PRESSURE (PSI)	WEIGHT (LBS)
		RETRACTED	EXTENDED						
TR2.5-2004-S	2" X 4"	14 1/4"	18 1/4"	1-1/8"	1"	SAE-08	7800	2500	16
TR2.5-2006-S	2" X 6"	16 1/4"	22 1/4"				7800	2500	17
TR2.5-2008-S	2" X 8"	18 1/4"	26 1/4"				7800	2500	19
TR2.5-2008-ASAE-S*	2" X 8"	20 1/4"	28 1/4"				7800	2500	20
TR2.5-2010-S	2" X 10"	20 1/4"	30 1/4"				7800	2500	20
TR2.5-2012-S	2" X 12"	22 1/4"	34 1/4"				7800	2500	22
TR2.5-2014-S	2" X 14"	24 1/4"	38 1/4"				7800	2500	24
TR2.5-2016-S	2" X 16"	26 1/4"	42 1/4"				7800	2500	25
TR2.5-2018-S	2" X 18"	28 1/4"	46 1/4"				7000	2200	27
TR2.5-2020-S	2" X 20"	30 1/4"	50 1/4"				5900	1900	28
TR2.5-2024-S	2" X 24"	34 1/4"	58 1/4"				4400	1400	31
TR2.5-2030-S	2" X 30"	40 1/4"	70 1/4"				3000	900	36
TR2.5-2036-S	2" X 36"	46 1/4"	82 1/4"				2200	700	41
TR2.5-2040-S	2" X 40"	50 1/4"	90 1/4"				1700	500	44
TR2.5-2048-S	2" X 48"	58 1/4"	106 1/4"				1300	400	49

COLUMN LOAD IS THE MAXIMUM PUSHING LOAD SUGGESTED USING A MINIMUM SAFETY FACTOR OF 2 AND BASED ON A PIN TO PIN MOUNTING CALCULATION.

* ASAE = AMERICAN SOCIETY OF AGRICULTURE ENGINEERS
 DESIGNATES AN INDUSTRY MOUNTING STANDARD FOR 8" AND 16" STROKE CYLINDERS

HYDRO CUSTOM IS NOT RESPONSIBLE FOR INCORRECT RESULTS OBTAINED WITH FIGURES IN THIS DOCUMENT. INFORMATION IS FOR REFERENCE ONLY.
 NO OTHER CONDITIONS ARE EXPRESSED OR IMPLIED.

HYDRAULIC CYLINDERS

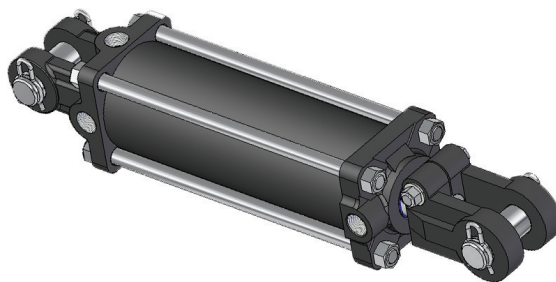

MODEL CODE	BORE X STROKE	DIMENSIONS		ROD DIAMETER	PIN SIZE	PORT SIZE	COLUMN LOADS (LBS)	PRESSURE (PSI)	WEIGHT (LBS)	
		RETRACTED	EXTENDED							
TR2.5-2504-S	2.5" X 4"	14 1/4"	18 1/4"	1-1/8"	1"	SAE-08	12200	2500	19	
TR2.5-2506-S	2.5" X 6"	16 1/4"	22 1/4"				12200	2500	21	
TR2.5-2508-S	2.5" X 8"	18 1/4"	26 1/4"				12200	2500	22	
TR2.5-2508-ASAE-S*	2.5" X 8"	20 1/4"	28 1/4"				12200	2500	23	
TR2.5-2510-S	2.5" X 10"	20 1/4"	30 1/4"				12200	2500	24	
TR2.5-2512-S	2.5" X 12"	22 1/4"	34 1/4"				12200	2500	26	
TR2.5-2514-S	2.5" X 14"	24 1/4"	38 1/4"				10300	2100	28	
TR2.5-2516-S	2.5" X 16"	26 1/4"	42 1/4"				8400	1700	29	
TR2.5-2518-S	2.5" X 18"	28 1/4"	46 1/4"				7000	1400	32	
TR2.5-2520-S	2.5" X 20"	30 1/4"	50 1/4"				5900	1200	34	
TR2.5-2524-S	2.5" X 24"	34 1/4"	58 1/4"	4400	900	38				
TR2.5-2530-S	2.5" X 30"	40 1/4"	70 1/4"	1-1/4"		4400	900	43		
TR2.5-2536-S	2.5" X 36"	46 1/4"	82 1/4"			3400	600	49		
TR2.5-2540-S	2.5" X 40"	50 1/4"	90 1/4"			2700	500	54		
TR2.5-2548-S	2.5" X 48"	58 1/4"	106 1/4"			2000	400	60		
TR2.5-3004-S	3" X 4"	14 1/4"	18 1/4"			1-1/4"	1"	17600	2500	24
TR2.5-3006-S	3" X 6"	16 1/4"	22 1/4"					17600	2500	26
TR2.5-3008-S	3" X 8"	18 1/4"	26 1/4"					17600	2500	28
TR2.5-3008-ASAE-S*	3" X 8"	20 1/4"	28 1/4"					17600	2500	29
TR2.5-3010-S	3" X 10"	20 1/4"	30 1/4"	17600	2500			30		
TR2.5-3012-S	3" X 12"	22 1/4"	34 1/4"	17600	2500			33		
TR2.5-3014-S	3" X 14"	24 1/4"	38 1/4"	15700	2200			35		
TR2.5-3016-S	3" X 16"	26 1/4"	42 1/4"	12800	1800			37		
TR2.5-3016-ASAE-S*	3" X 16"	31 1/2"	47 1/2"	1-1/2"	1-1/4"			9200	1300	42
TR2.5-3018-S	3" X 18"	28 1/4"	46 1/4"	1-1/4"				11300	1600	42
TR2.5-3020-S	3" X 20"	30 1/4"	50 1/4"			9200	1300	44		
TR2.5-3024-S	3" X 24"	34 1/4"	58 1/4"	1-1/2"	1"	6700	900	49		
TR2.5-3030-S	3" X 30"	40 1/4"	70 1/4"			9600	1300	57		
TR2.5-3036-S	3" X 36"	46 1/4"	82 1/4"			7000	900	65		
TR2.5-3040-S	3" X 40"	50 1/4"	90 1/4"			5700	800	70		
TR2.5-3048-S	3" X 48"	58 1/4"	106 1/4"			3900	500	80		
TR2.5-3504-S	3.5" X 4"	14 1/4"	18 1/4"			1 1/4"	1"	24000	2500	29
TR2.5-3506-S	3.5" X 6"	16 1/4"	22 1/4"	24000	2500			32		
TR2.5-3508-S	3.5" X 8"	18 1/4"	26 1/4"	24000	2500			34		
TR2.5-3508-ASAE-S*	3.5" X 8"	20 1/4"	28 1/4"	24000	2500			35		
TR2.5-3510-S	3.5" X 10"	20 1/4"	30 1/4"	24000	2500			37		
TR2.5-3512-S	3.5" X 12"	22 1/4"	34 1/4"	19600	2000			39		
TR2.5-3514-S	3.5" X 14"	24 1/4"	38 1/4"	15700	1600			42		
TR2.5-3516-S	3.5" X 16"	26 1/4"	42 1/4"	12800	1300			44		
TR2.5-3516-ASAE-S*	3.5" X 16"	31 1/2"	47 1/2"	1 1/2"	1 1/4"			21100	2100	50
TR2.5-3518-S	3.5" X 18"	28 1/4"	46 1/4"	1 1/4"				10700	1100	47
TR2.5-3520-S	3.5" X 20"	30 1/4"	50 1/4"			9100	900	49		
TR2.5-3524-S	3.5" X 24"	34 1/4"	58 1/4"	1 1/2"	1"	14000	1400	58		
TR2.5-3530-S	3.5" X 30"	40 1/4"	70 1/4"			9600	1000	66		
TR2.5-3536-S	3.5" X 36"	46 1/4"	82 1/4"			7000	700	74		
TR2.5-3540-S	3.5" X 40"	50 1/4"	90 1/4"			5800	600	80		
TR2.5-3548-S	3.5" X 48"	58 1/4"	106 1/4"			3900	400	91		

COLUMN LOAD IS THE MAXIMUM PUSHING LOAD SUGGESTED USING A MINIMUM SAFETY FACTOR OF 2 AND BASED ON A PIN TO PIN MOUNTING CALCULATION.

* ASAE = AMERICAN SOCIETY OF AGRICULTURE ENGINEERS
 DESIGNATES AN INDUSTRY MOUNTING STANDARD FOR 8" AND 16" STROKE CYLINDERS

HYDRO CUSTOM IS NOT RESPONSIBLE FOR INCORRECT RESULTS OBTAINED WITH FIGURES IN THIS DOCUMENT. INFORMATION IS FOR REFERENCE ONLY. NO OTHER CONDITIONS ARE EXPRESSED OR IMPLIED.

MODEL CODE	BORE X STROKE	DIMENSIONS		ROD DIAMETER	PIN SIZE	PORT SIZE	COLUMN LOADS (LBS)	PRESSURE (PSI)	WEIGHT (LBS)		
		RETRACTED	EXTENDED								
TR2.5-4004-S	4" X 4"	14 1/4"	18 1/4"	1 1/2"	1"	SAE-08	31400	2500	33		
TR2.5-4006-S	4" X 6"	16 1/4"	22 1/4"				31400	2500	36		
TR2.5-4008-S	4" X 8"	18 1/4"	26 1/4"				31400	2500	38		
TR2.5-4008-ASAE-S*	4" X 8"	20 1/4"	28 1/4"				31400	2500	39		
TR2.5-4010-S	4" X 10"	20 1/4"	30 1/4"				31400	2500	41		
TR2.5-4012-S	4" X 12"	22 1/4"	34 1/4"				31400	2500	44		
TR2.5-4014-S	4" X 14"	24 1/4"	38 1/4"				31400	2500	46		
TR2.5-4016-S	4" X 16"	26 1/4"	42 1/4"				26700	2100	49		
TR2.5-4016-ASAE-S*	4" X 16"	31 1/2"	47 1/2"				2"	1 1/4"	31400	2500	63
TR2.5-4018-S	4" X 18"	28 1/4"	46 1/4"				1 1/2"	1"	22300	1700	55
TR2.5-4020-S	4" X 20"	30 1/4"	50 1/4"	18800	1500	58					
TR2.5-4024-S	4" X 24"	34 1/4"	58 1/4"	14000	1100	64					
TR2.5-4024-175-S	4" X 24"	34 1/4"	58 1/4"	26000	2050	68					
TR2.5-4024-200-S	4" X 24"	34 1/4"	58 1/4"	1 3/4"	1"	31400	2500	73			
TR2.5-4030-S	4" X 30"	40 1/4"	70 1/4"			30500	2400	84			
TR2.5-4036-S	4" X 36"	46 1/4"	82 1/4"	2"	1"	22200	1700	95			
TR2.5-4040-S	4" X 40"	50 1/4"	90 1/4"			18200	1400	103			
TR2.5-4048-S	4" X 48"	58 1/4"	106 1/4"			13200	1000	118			

COLUMN LOAD IS THE MAXIMUM PUSHING LOAD SUGGESTED USING A MINIMUM SAFETY FACTOR OF 2 AND BASED ON A PIN TO PIN MOUNTING CALCULATION.

* ASAE = AMERICAN SOCIETY OF AGRICULTURE ENGINEERS
 DESIGNATES AN INDUSTRY MOUNTING STANDARD FOR 8" AND 16" STROKE CYLINDERS

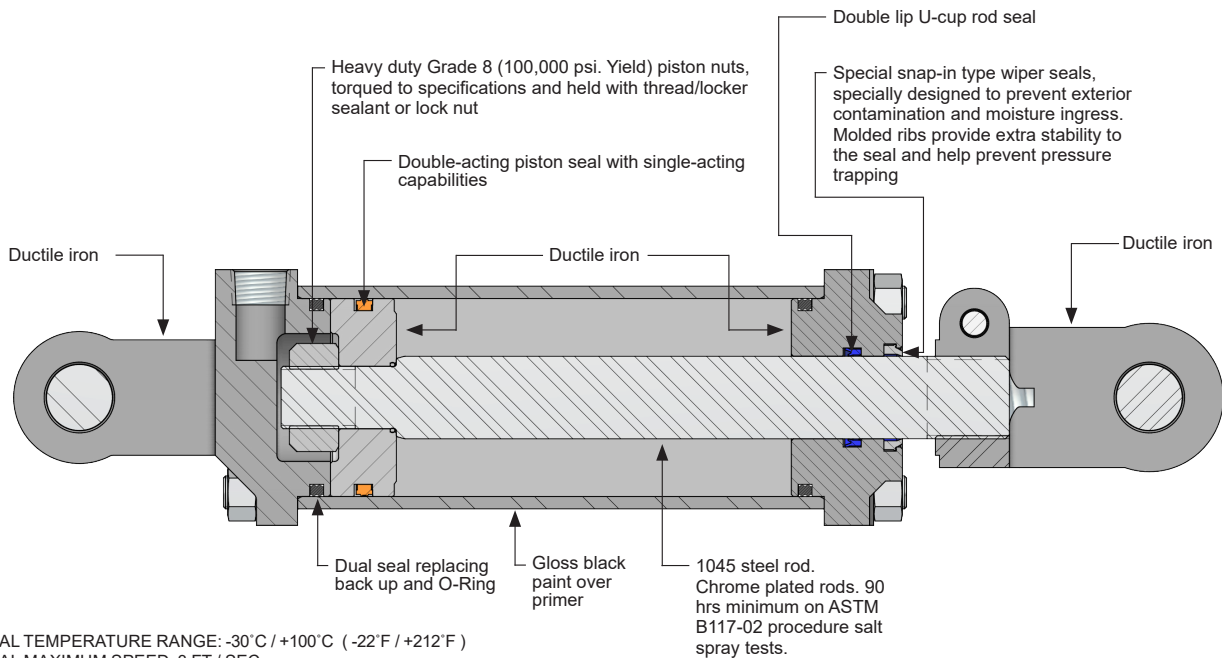

SEAL TEMPERATURE RANGE: -30°C / +100°C (-22°F / +212°F)
 SEAL MAXIMUM SPEED: 3 FT / SEC

- All seals are top grade/first quality North American made
- All components are CNC machined for higher accuracy and conformity
- Quality controlled in China by qualified Canadian technicians
- 100% tested. All cylinders are submitted to static and dynamic pressure tests to recommended specifications

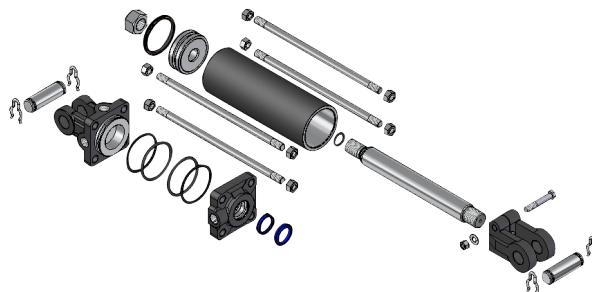

HYDRAULIC CYLINDERS

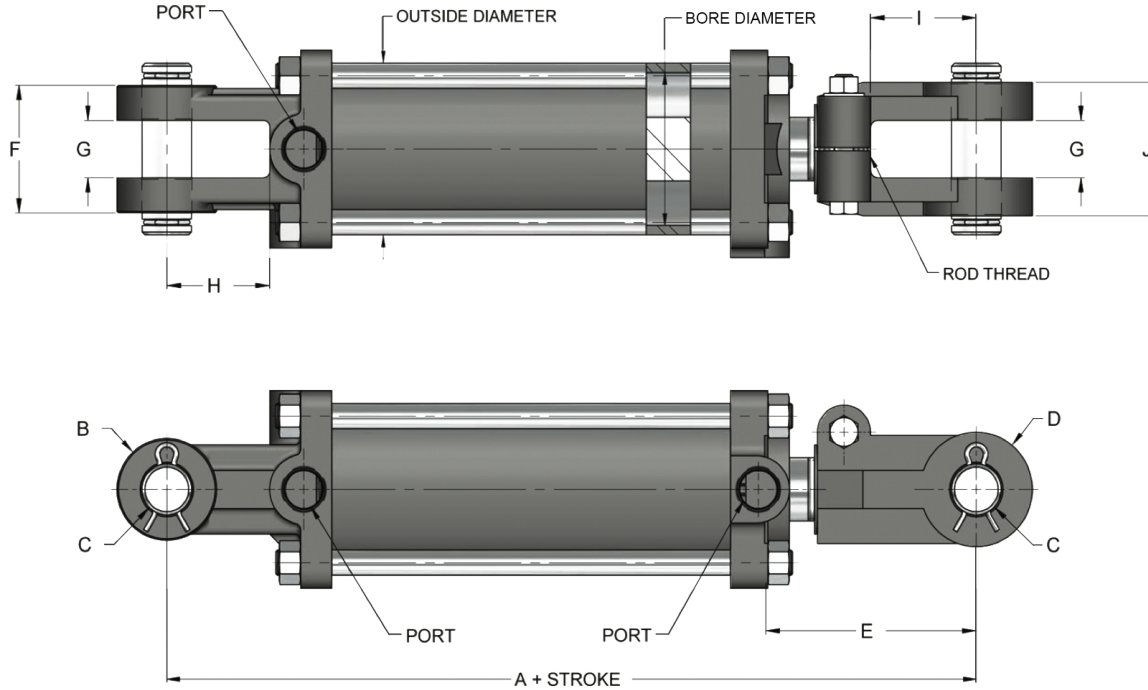

MODEL CODE	CYLINDER BORE	OUTSIDE DIAMETER	ROD THREAD	A2	B	C3	D4	E5	F	G	H	I	J4	PORT SIZE*
TR3-20XX	2.00	2.38	1 1/8-12 UNF	10.25	2.00	1.01	2.00	4.17	2.44	1.14	2.00	2.12	2.50	SAE-08
TR3-25XX	2.50	2.89	1 1/8-12 UNF	10.25	2.00	1.01	2.00	4.17	2.44	1.14	2.00	2.12	2.50	SAE-08
TR3-30XX	3.00	3.39	1 1/4-12 UNF	10.25	2.00	1.01	2.00	4.14	2.72	1.14	2.00	2.12	2.72	SAE-08
TR3-35XX	3.50	4.00	1 1/4-12 UNF	10.25	2.00	1.01	2.00	4.09	2.72	1.14	2.00	2.12	2.72	SAE-08
TR3-40XX	4.00	4.50	1 1/4-12 UNF	10.25	2.00	1.01	2.00	3.82	2.72	1.14	2.12	2.12	2.72	SAE-08
TR3-50XX	5.00	5.50	1 1/2-12 UNF	12.25	2.75	1.26	2.75	5.00	2.87	1.25	2.12	2.12	2.95	SAE-10

- FOR 8.00" ASAE STROKE : A = 12.25"
FOR 16.00" ASAE STROKE : A = 15.50"
 - FOR 16.00" ASAE STROKE : C = 1.26"
 - FOR 8.00" ASAE STROKE : E = 5.75" (2.00" TO 3.00" BORE), E = 5.62" (3.50" BORE) E = 5.56" (4.00" BORE)
FOR 16.00" ASAE STROKE : E = 9.00" (3.00" BORE) E = 8.87" (3.50" BORE) E = 8.81" (4.00" BORE) E = 7.43" (5.00" BORE)
 - FOR 5.00" BORE : G (FRONT CLEVIS) = 1.18" G (END CAP) = 1.31"
- MAXIMUM RETRACTED WORKING PRESSURE = 3000 PSI
MAXIMUM EXTENDED WORKING PRESSURE = SEE TABLE
RETRACTED AND STROKE TOLERANCE ± 1/8"
DIMENSIONS A AND E ARE FOR REFERENCES ONLY AS CLEVIS IS ADJUSTABLE
* NPT PORTS ARE ALSO AVAILABLE.

MODEL CODE	BORE X STROKE	DIMENSIONS		ROD DIAMETER	PIN SIZE	PORT SIZE*	COLUMN LOADS (LBS)	PRESSURE (PSI)	WEIGHT (LBS)
		RETRACTED	EXTENDED						
TR3-2004	2" X 4"	14-1/4"	18-1/4"	1-1/8"	1"	SAE-08	9400	3000	17
TR3-2006	2" X 6"	16-1/4"	22-1/4"				9400	3000	19
TR3-2008	2" X 8"	18-1/4"	26-1/4"				9400	3000	21
TR3-2008-ASAE*	2" X 8"	20-1/4"	28-1/4"				9400	3000	22
TR3-2010	2" X 10"	20-1/4"	30-1/4"				9400	3000	23
TR3-2012	2" X 12"	22-1/4"	34-1/4"				9400	3000	25
TR3-2014	2" X 14"	24-1/4"	38-1/4"				9400	3000	27
TR3-2016	2" X 16"	26-1/4"	42-1/4"				8400	2600	28
TR3-2018	2" X 18"	28-1/4"	46-1/4"				7000	2200	30
TR3-2020	2" X 20"	30-1/4"	50-1/4"				5900	1900	32
TR3-2024	2" X 24"	34-1/4"	58-1/4"				4400	1400	36
TR3-2030	2" X 30"	40-1/4"	70-1/4"				3000	900	41
TR3-2036	2" X 36"	46-1/4"	82-1/4"				2200	700	47

COLUMN LOAD IS THE MAXIMUM PUSHING LOAD SUGGESTED USING A MINIMUM SAFETY FACTOR OF 2 AND BASED ON A PIN TO PIN MOUNTING CALCULATION.

* ASAE = AMERICAN SOCIETY OF AGRICULTURE ENGINEERS
DESIGNATES AN INDUSTRY MOUNTING STANDARD FOR 8" AND 16" STROKE CYLINDERS

HYDRO CUSTOM IS NOT RESPONSIBLE FOR INCORRECT RESULTS OBTAINED WITH FIGURES IN THIS DOCUMENT. INFORMATION IS FOR REFERENCE ONLY.
NO OTHER CONDITIONS ARE EXPRESSED OR IMPLIED.



MODEL CODE	BORE X STROKE	DIMENSIONS		ROD DIAMETER	PIN SIZE	PORT SIZE*	COLUMN LOADS (LBS)	PRESSURE (PSI)	WEIGHT (LBS)			
		RETRACTED	EXTENDED									
TR3-2504	2.5" X 4"	14-1/4"	18-1/4"	1-1/4"	1"	SAE-08	14700	3000	22			
TR3-2506	2.5" X 6"	16-1/4"	22-1/4"				14700	3000	24			
TR3-2508	2.5" X 8"	18-1/4"	26-1/4"				14700	3000	26			
TR3-2508-ASAE*	2.5" X 8"	20-1/4"	28-1/4"				14700	3000	27			
TR3-2510	2.5" X 10"	20-1/4"	30-1/4"				14700	3000	29			
TR3-2512	2.5" X 12"	22-1/4"	34-1/4"				14700	3000	31			
TR3-2514	2.5" X 14"	24-1/4"	38-1/4"				14700	3000	34			
TR3-2516	2.5" X 16"	26-1/4"	42-1/4"				12800	2600	36			
TR3-2518	2.5" X 18"	28-1/4"	46-1/4"				10700	2100	38			
TR3-2520	2.5" X 20"	30-1/4"	50-1/4"				9100	1800	41			
TR3-2524	2.5" X 24"	34-1/4"	58-1/4"				6700	1300	45			
TR3-2530	2.5" X 30"	40-1/4"	70-1/4"				4600	900	53			
TR3-2536	2.5" X 36"	46-1/4"	82-1/4"				3400	600	60			
TR3-3004	3" X 4"	14-1/4"	18-1/4"				1-1/4"	1"	SAE-08	21200	3000	26
TR3-3006	3" X 6"	16-1/4"	22-1/4"	21200	3000	29						
TR3-3008	3" X 8"	18-1/4"	26-1/4"	21200	3000	32						
TR3-3008-ASAE*	3" X 8"	20-1/4"	28-1/4"	21200	3000	32						
TR3-3010	3" X 10"	20-1/4"	30-1/4"	21200	3000	34						
TR3-3012	3" X 12"	22-1/4"	34-1/4"	21200	3000	37						
TR3-3014	3" X 14"	24-1/4"	38-1/4"	21200	3000	40						
TR3-3016	3" X 16"	26-1/4"	42-1/4"	18800	2600	43						
TR3-3016-ASAE*	3" X 16"	31-1/2"	47-1/2"	14900	2100	45						
TR3-3018	3" X 18"	28-1/4"	46-1/4"	15700	2200	45						
TR3-3020	3" X 20"	30-1/4"	50-1/4"	1-1/2"	1"	SAE-08	13300	1800	48			
TR3-3024	3" X 24"	34-1/4"	58-1/4"				9900	1400	53			
TR3-3030	3" X 30"	40-1/4"	70-1/4"				6800	900	62			
TR3-3036	3" X 36"	46-1/4"	82-1/4"				4900	700	70			
TR3-3504	3.5" X 4"	14-1/4"	18-1/4"				1-3/8"	1"	SAE-08	28800	3000	34
TR3-3506	3.5" X 6"	16-1/4"	22-1/4"							28800	3000	37
TR3-3508	3.5" X 8"	18-1/4"	26-1/4"	28800	3000	40						
TR3-3508-ASAE*	3.5" X 8"	20-1/4"	28-1/4"	28800	3000	41						
TR3-3510	3.5" X 10"	20-1/4"	30-1/4"	28300	2900	44						
TR3-3512	3.5" X 12"	22-1/4"	34-1/4"	28700	2900	47						
TR3-3514	3.5" X 14"	24-1/4"	38-1/4"	23000	2300	50						
TR3-3516	3.5" X 16"	26-1/4"	42-1/4"	18800	1900	53						
TR3-3516-ASAE*	3.5" X 16"	31-1/2"	47-1/2"	14900	1500	56						
TR3-3518	3.5" X 18"	28-1/4"	46-1/4"	15700	1600	56						
TR3-3520	3.5" X 20"	30-1/4"	50-1/4"	1-1/2"	1"	SAE-08	13300	1300	60			
TR3-3524	3.5" X 24"	34-1/4"	58-1/4"				9900	1000	66			
TR3-3530	3.5" X 30"	40-1/4"	70-1/4"				6800	700	76			
TR3-3536	3.5" X 36"	46-1/4"	82-1/4"				4900	500	85			

COLUMN LOAD IS THE MAXIMUM PUSHING LOAD SUGGESTED USING A MINIMUM SAFETY FACTOR OF 2 AND BASED ON A PIN TO PIN MOUNTING CALCULATION.

* ASAE = AMERICAN SOCIETY OF AGRICULTURE ENGINEERS
DESIGNATES AN INDUSTRY MOUNTING STANDARD FOR 8" AND 16" STROKE CYLINDERS

HYDRO CUSTOM IS NOT RESPONSIBLE FOR INCORRECT RESULTS OBTAINED WITH FIGURES IN THIS DOCUMENT. INFORMATION IS FOR REFERENCE ONLY. NO OTHER CONDITIONS ARE EXPRESSED OR IMPLIED.



MODEL CODE	BORE X STROKE	DIMENSIONS		ROD DIAMETER	PIN SIZE	PORT SIZE	COLUMN LOADS (LBS)	PRESSURE (PSI)	WEIGHT (LBS)
		RETRACTED	EXTENDED						
TR3-4004	4" X 4"	14-1/4"	18-1/4"	1-1/2"	1"	SAE-08	37600	3000	41
TR3-4006	4" X 6"	16-1/4"	22-1/4"				37600	3000	45
TR3-4008	4" X 8"	18-1/4"	26-1/4"				37600	3000	49
TR3-4008-ASAE*	4" X 8"	20-1/4"	28-1/4"				37600	3000	50
TR3-4010	4" X 10"	20-1/4"	30-1/4"				37600	3000	52
TR3-4012	4" X 12"	22-1/4"	34-1/4"				37600	3000	56
TR3-4014	4" X 14"	24-1/4"	38-1/4"				37600	3000	60
TR3-4016	4" X 16"	26-1/4"	42-1/4"	1-3/4"	1-1/4"	SAE-08	37600	3000	64
TR3-4016-ASAE*	4" X 16"	31-1/2"	47-1/2"				37600	3000	68
TR3-4018	4" X 18"	28-1/4"	46-1/4"	2"	1"	SAE-08	37600	3000	68
TR3-4020	4" X 20"	30-1/4"	50-1/4"				35000	2700	72
TR3-4024	4" X 24"	34-1/4"	58-1/4"				26000	2000	80
TR3-4030	4" X 30"	40-1/4"	70-1/4"	2"	1"	SAE-08	17900	1400	92
TR3-4036	4" X 36"	46-1/4"	82-1/4"				13000	1000	104
TR3-5004	5" X 4"	16-1/4"	20-1/4"				2"	1-1/4"	SAE-08
TR3-5006	5" X 6"	18-1/4"	24-1/4"	58900	3000	76			
TR3-5008-ASAE*	5" X 8"	22-1/4"	30-1/4"	58900	3000	81			
TR3-5010	5" X 10"	22-1/4"	32-1/4"	58900	3000	86			
TR3-5012	5" X 12"	24-1/4"	36-1/4"	58900	3000	91			
TR3-5014	5" X 14"	26-1/4"	40-1/4"	58900	3000	96			
TR3-5016	5" X 16"	28-1/4"	44-1/4"	58900	3000	101			
TR3-5016-ASAE*	5" X 16"	31-1/2"	47-1/2"	58900	3000	104			
TR3-5018	5" X 18"	30-1/4"	48-1/4"	58900	3000	106			
TR3-5020	5" X 20"	32-1/4"	52-1/4"	55200	2800	112			
TR3-5024	5" X 24"	36-1/4"	60-1/4"	41500	2100	122			
TR3-5030	5" X 30"	42-1/4"	72-1/4"	28800	1400	137			
TR3-5036	5" X 36"	48-1/4"	84-1/4"	21200	1000	153			

COLUMN LOAD IS THE MAXIMUM PUSHING LOAD SUGGESTED USING A MINIMUM SAFETY FACTOR OF 2 AND BASED ON A PIN TO PIN MOUNTING CALCULATION.

* ASAE = AMERICAN SOCIETY OF AGRICULTURE ENGINEERS

DESIGNATES AN INDUSTRY MOUNTING STANDARD FOR 8" AND 16" STROKE CYLINDERS

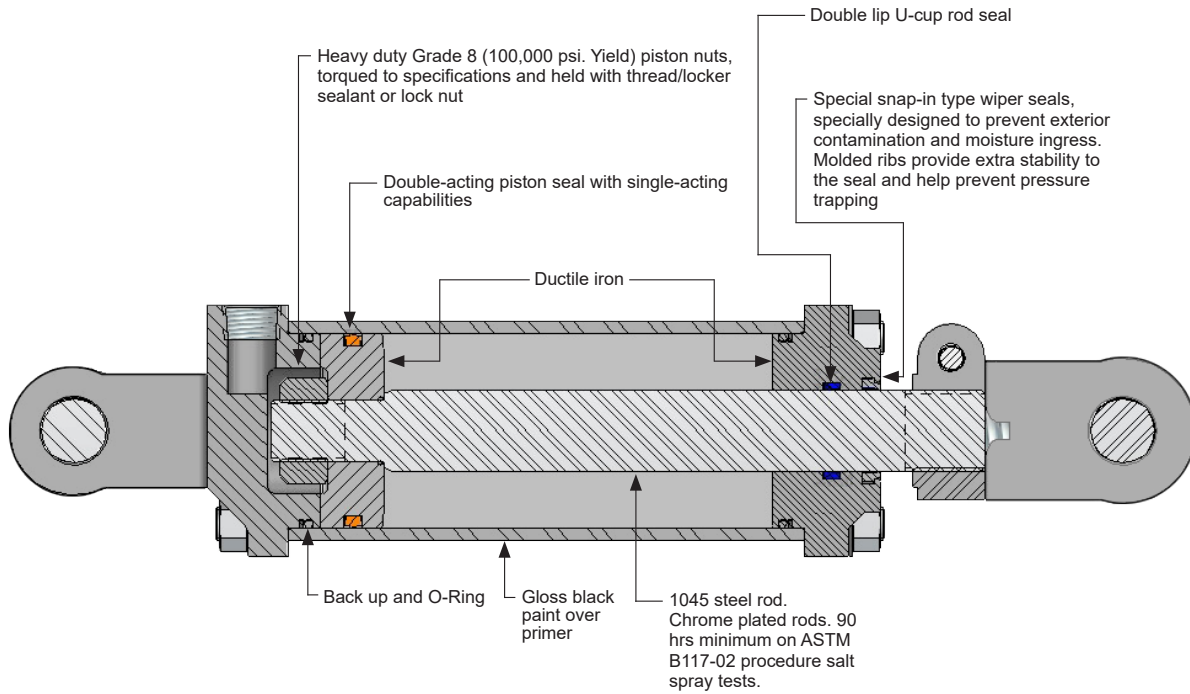

SEAL TEMPERATURE RANGE : -30°C / +100°C (-22°F / +212°F)
 SEAL MAXIMUM SPEED : 3 FT / SEC

- All seals are top grade/first quality North American made
- All components are CNC machined for higher accuracy and conformity
- Quality controlled in China by qualified Canadian technicians
- 100% tested. All cylinders are submitted to static and dynamic pressure tests to recommended specifications

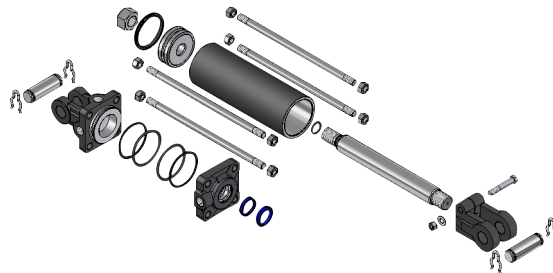

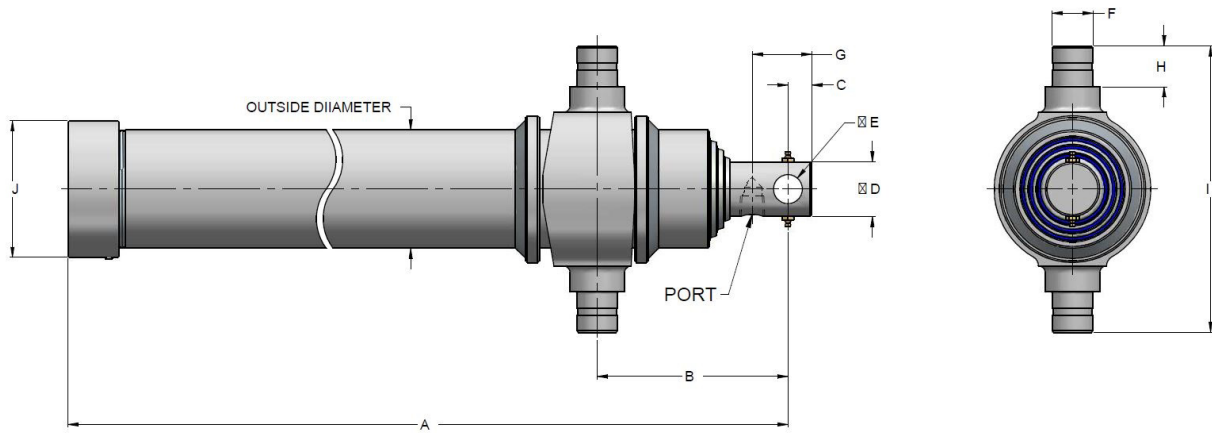

7 TONS CAPACITY

MODEL CODE	STROKE	MAX PSI	OUTSIDE DIAMETER	DIMENSIONS (IN)										PORT SIZE	WEIGHT (LBS)
				A	B	C	D	E	F	G	H	I	J		
TC-07833-S	78"	2100	3.75	34.62	7.00	0.87	2.00	1.015	1.25	2.25	1.25	9.00	4.25	SAE-08	86
TC-09033-S	90"		38.62	94											
TC-10833-S	108"		44.62	106											

RETRACTED TOLERANCE ± 1/8"

12 TONS CAPACITY

MODEL CODE	STROKE	MAX PSI	OUTSIDE DIAMETER	DIMENSIONS (IN)										PORT SIZE	WEIGHT (LBS)
				A	B	C	D	E	F	G	H	I	J		
TC-07843-S	78"	2450	4.50	33.87	7.00	0.87	2.00	1.015	1.50	2.25	1.50	10.50	5.00	SAE-08	99
TC-09043-S	90"		37.87	109											
TC-10843-S	108"		43.87	125											
TC-12043-S	120"		47.87	138											
TC-12043M-S	120"		47.87	13.00	137										
TC-13243M-S	132"		51.87		157										
TC-14443M-S	144"		55.87		171										

RETRACTED TOLERANCE ± 1/8"

BRACKETS

MODEL CODE	DESCRIPTION
TC-SB	BRACKET FOR 7 AND 12 TONS
TC-S07	BOX BRACKET KIT 7 TONS
TC-S12	BOX BRACKET KIT 12 TONS

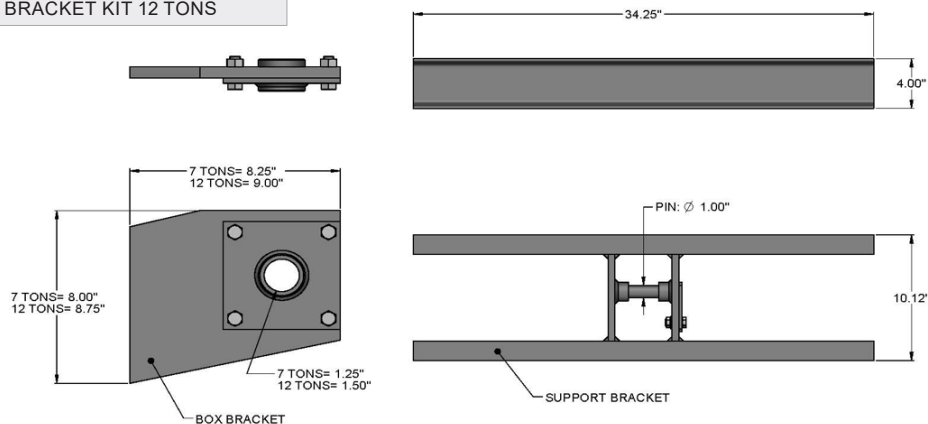

HYDRO CUSTOM IS NOT RESPONSIBLE FOR INCORRECT RESULTS OBTAINED WITH FIGURES IN THIS DOCUMENT. INFORMATION IS FOR REFERENCE ONLY. NO OTHER CONDITIONS ARE EXPRESSED OR IMPLIED.

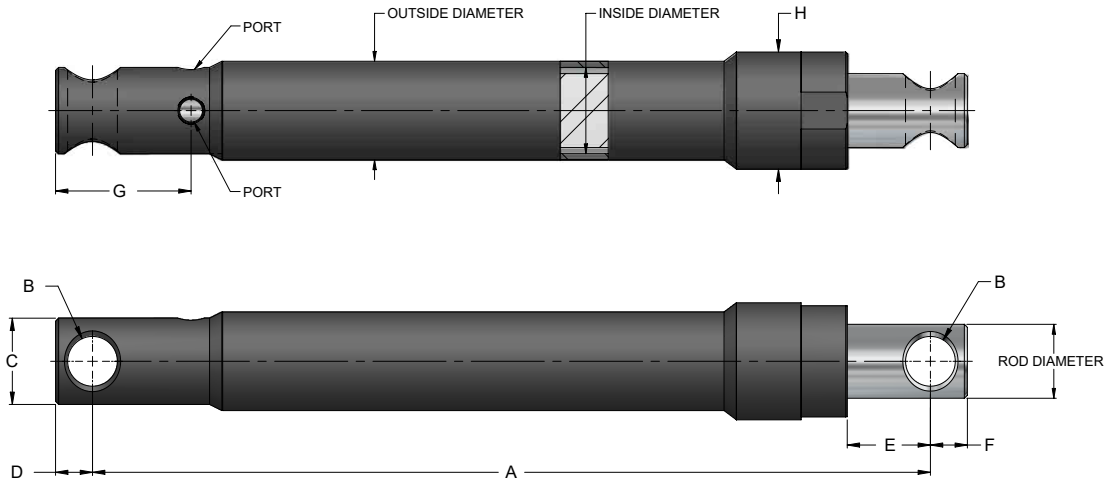

MODEL CODE	EQUIVALENT	BORE X STROKE	OUTSIDE DIAMETER	ROD DIAMETER	DIMENSIONS (IN)								PORT SIZE	WEIGHT (LBS)
					A	B	C	D	E	F	G	H		
ASP-1510-0750	ARCTIC	1.75" X 10"	2.0	1.5	17.00	0.76	1.75	0.75	1.68	0.75	2.75	2.37	1/4-NPT	12
ASP-1512-0750	ARCTIC	1.75" X 12"	2.0	1.5	19.00	0.76	1.75	0.75	1.68	0.75	2.75	2.37	1/4-NPT	13
FSP-1510-1000	FISHER	1.75" X 10"	2.0	1.5	17.00	1.01	1.75	0.75	1.68	0.75	2.75	2.37	1/4-NPT	11
FSP-1512-1000	FISHER	1.75" X 12"	2.0	1.5	19.25	1.01	1.75	0.75	1.93	0.75	2.75	2.37	1/4-NPT	13
FSP-2016-1250	FISHER	2.25" X 16"	2.5	2.0	23.25	1.26	2.25	0.87	1.75	0.87	2.75	3.00	1/4-NPT	27
MSP-1506-0625	MEYER	1.75" X 6"	2.0	1.5	12.37	0.63	1.62	0.75	1.56	0.75	2.12	2.37	1/4-NPT	9
MSP-1510-0625	MEYER	1.75" X 10"	2.0	1.5	16.18	0.63	1.62	0.75	1.62	0.75	2.12	2.37	1/4-NPT	14
MSP-1512-0625	MEYER	1.75" X 12"	2.0	1.5	18.00	0.63	1.62	0.75	1.43	0.75	2.12	2.37	1/4-NPT	15
MSP-2012-0625	MEYER	2.25" X 12"	2.5	2.0	18.00	0.63	1.62	0.75	0.75	0.75	2.25	3.00	1/4-NPT	24
WSP-1506-0750	WESTERN	1.75" X 6"	2.0	1.5	13.00	0.76	1.75	0.68	1.37	0.68	2.75	2.37	1/4-NPT	11
WSP-1508-0750	WESTERN	1.75" X 8"	2.0	1.5	15.25	0.76	1.75	0.68	1.62	0.68	2.75	2.37	1/4-NPT	12
WSP-1510-0750	WESTERN	1.75" X 10"	2.0	1.5	17.25	0.76	1.75	0.68	1.62	0.68	2.75	2.37	1/4-NPT	14
WSP-1510-1000	WESTERN	1.75" X 10"	2.0	1.5	17.00	1.01	1.75	0.75	1.43	0.75	2.75	2.37	1/4-NPT	14
WSP-2006-0750	WESTERN	2.25" X 6"	2.5	2.0	13.18	0.76	2.25	0.75	1.56	0.75	2.75	3.00	1/4-NPT	18
WSP-2010-1000	WESTERN	2.25" X 10"	2.5	2.0	17.25	1.01	2.25	0.75	1.62	0.75	2.75	3.00	1/4-NPT	22
WSP-2016-1000	WESTERN	2.25" X 16"	2.5	2.0	23.31	1.01	2.25	0.75	1.68	0.75	2.56	3.00	1/4-NPT	31

SEAL TEMPERATURE RANGE : -30°C / +100°C (-22°F / +212°F)
 SEAL MAXIMUM SPEED : 3 FT / SEC
 CYLINDER WITH 1 PORT = PORT IN LINE WITH PIN HOLE
 RETRACTED AND STROKE TOLERANCE ± 1/8"

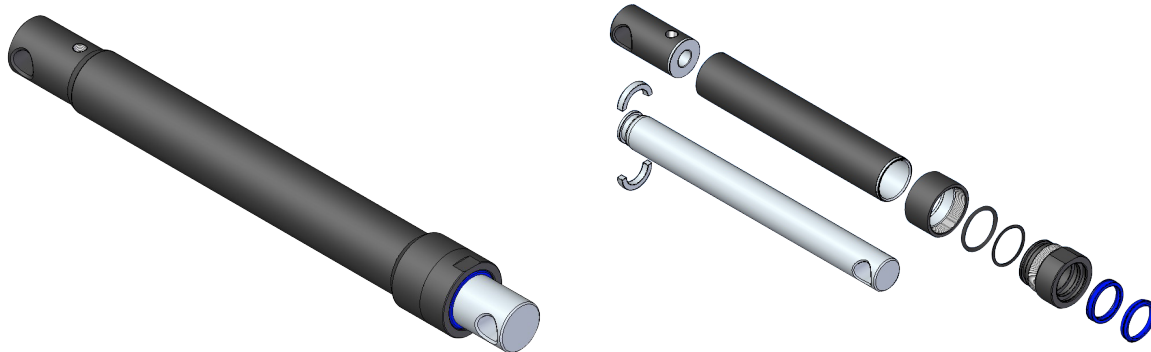

■ FEMALE CLEVIS

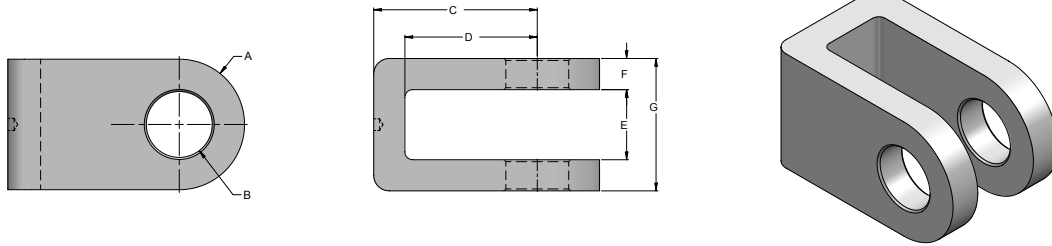

MODEL CODE	DIMENSIONS (IN)							MAXIMUM LOAD PUSH / PULL (LBS)
	A	B	C	D	E	F	G	
CL-100075-CLP	1.50	0.76	1.75	1.37	0.87	0.37	1.62	5300
CL-125100-CLP	2.00	1.01	2.62	2.12	1.12	0.50	2.12	22500
CL-175100-CLP	2.00	1.01	2.62	2.12	1.12	0.62	2.37	28100
CL-200100-CLP	2.00	1.01	2.62	2.00	1.12	0.62	2.37	28100
CL-250150-CLP	3.00	1.51	3.00	2.25	1.62	0.75	3.12	50600

MATERIAL : C1045 CAST STEEL

MAXIMUM PUSHING & PULLING FORCE ARE BASED ON A SUGGESTED MINIMUM SAFETY FACTOR OF 2

■ THREADED CLEVIS

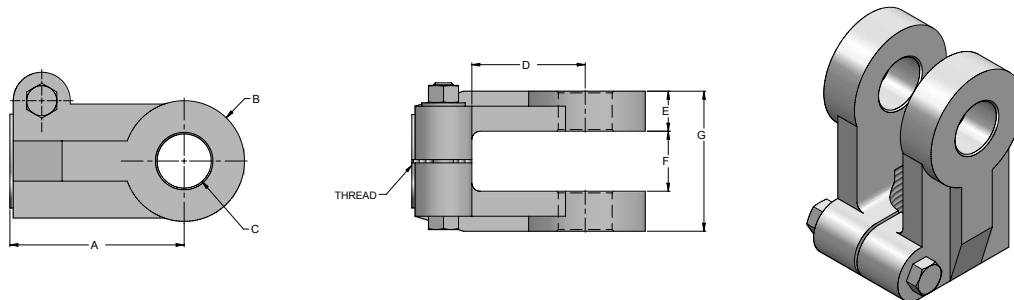

MODEL CODE	THREAD	DIMENSIONS (IN)							MAXIMUM LOAD PUSH / PULL (LBS)
		A	B	C	D	E	F	G	
ST-0870718-CVP	7/8-14 UNF	2.75	1.87	0.76	1.62	0.56	0.87	2.00	5300
ST-1121020-CVP	1 1/8-12 UNF	3.25	2.00	1.01	2.12	0.75	1.12	2.62	23000
ST-1121022-CVP	1 1/8-12 UNF	3.25	2.25	1.01	2.12	0.75	1.12	2.62	23000
ST-1121222-CVP	1 1/8-12 UNF	3.25	2.25	1.26	2.12	0.75	1.12	2.62	23000
ST-1251022-CVP	1 1/4-12 UNF	3.25	2.25	1.01	2.12	0.75	1.12	2.62	23000
ST-1311025-CVP	1 5/16-12 UN	3.25	2.50	1.01	2.12	0.81	1.12	2.75	33700
ST-1311225-CVP	1 5/16-12 UN	3.25	2.50	1.26	2.12	0.81	1.12	2.75	33700
ST-1501025-CVP	1 1/2-12 UNF	3.25	2.50	1.01	2.12	0.81	1.12	2.75	33700
ST-1501225-CVP	1 1/2-12 UNF	3.25	2.50	1.26	2.12	0.81	1.12	2.75	33700
ST-1501226-CVP	1 1/2-12 UNF	3.62	2.75	1.26	2.12	1.06	1.18	3.31	58900

MAXIMUM PUSHING & PULLING FORCE ARE BASED ON A SUGGESTED MINIMUM SAFETY FACTOR OF 2

HYDRO CUSTOM IS NOT RESPONSIBLE FOR INCORRECT RESULTS OBTAINED WITH FIGURES IN THIS DOCUMENT. INFORMATION IS FOR REFERENCE ONLY. NO OTHER CONDITIONS ARE EXPRESSED OR IMPLIED.

WELDING PORTS

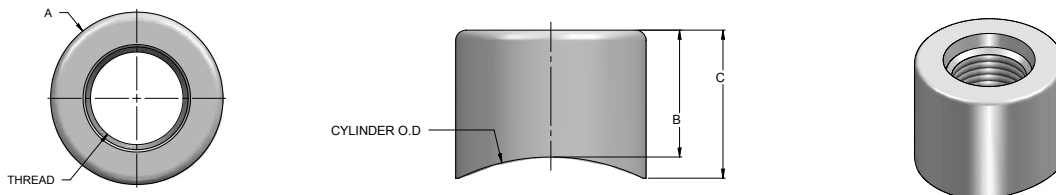

NPT PORTS

MODEL CODE	THREAD	DIMENSIONS (IN)			
		CYLINDER O.D.	A	B	C
025N-200062-POP	1/4 NPT	2.00	0.87	0.62	0.68
037N-250075-POP	3/8 NPT	2.50	1.12	0.75	0.87
050N-300087-POP	1/2 NPT	3.00	1.25	0.87	0.93
050N-350087-POP	1/2 NPT	3.50	1.25	0.87	0.93
050N-400087-POP	1/2 NPT	4.00	1.25	0.87	0.93
050N-450087-POP	1/2 NPT	4.50	1.25	0.87	0.93
075N-550100-POP	3/4 NPT	5.50	1.37	1.00	1.06

SAE PORTS

MODEL CODE	THREAD	DIMENSIONS (IN)			
		CYLINDER O.D.	A	B	C
04S-200062-POP	SAE-04	2.00	0.75	0.62	0.68
06S-250075-POP	SAE-06	2.50	1.00	0.75	0.81
08S-300093-POP	SAE-08	3.00	1.12	0.93	1.00
08S-350093-POP	SAE-08	3.50	1.12	0.93	1.00
08S-400093-POP	SAE-08	4.00	1.12	0.93	1.00
08S-450093-POP	SAE-08	4.50	1.12	0.93	1.00
12S-550100-POP	SAE-12	5.50	1.50	1.00	1.06

MATERIAL : C1020 STEEL
 MAXIMUM OPERATING PRESSURE : 3000 psi (SAFETY FACTOR = 2)

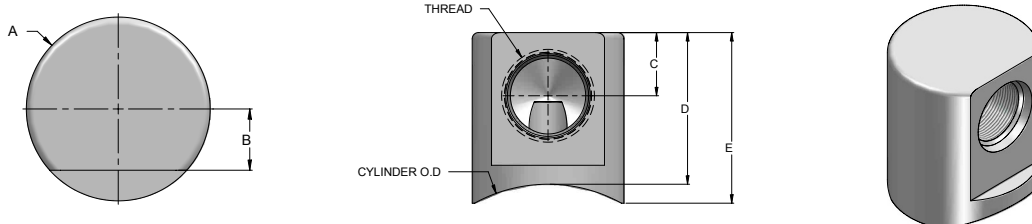

90 DEGREES PORTS

MODEL CODE	THREAD	DIMENSIONS (IN)					
		CYLINDER O.D.	A	B	C	D	E
025N-200112-90POP	1/4 NPT	2.00	1.12	0.37	0.43	1.12	1.25
037N-250125-90POP	3/8 NPT	2.50	1.25	0.43	0.50	1.25	1.37
050N-300150-90POP	1/2 NPT	3.00	1.62	0.50	0.62	1.50	1.68
050N-350150-90POP	1/2 NPT	3.50	1.62	0.50	0.62	1.50	1.62
050N-400150-90POP	1/2 NPT	4.00	1.62	0.50	0.62	1.50	1.62
050N-450150-90POP	1/2 NPT	4.50	1.62	0.50	0.62	1.50	1.62
075N-550200-90POP	3/4 NPT	5.50	2.12	0.62	0.87	2.00	2.18
04S-200112-90POP	SAE-04	2.00	1.12	0.37	0.43	1.12	1.25
06S-250125-90POP	SAE-06	2.50	1.25	0.43	0.50	1.25	1.37
08S-300150-90POP	SAE-08	3.00	1.62	0.50	0.62	1.50	1.68
08S-350150-90POP	SAE-08	3.50	1.62	0.50	0.62	1.50	1.62
08S-400150-90POP	SAE-08	4.00	1.62	0.50	0.62	1.50	1.62
08S-450150-90POP	SAE-08	4.50	1.62	0.50	0.62	1.50	1.62
12S-550200-90POP	SAE-12	5.50	2.12	0.62	0.81	2.00	2.18

MATERIAL : C1020 STEEL
 MAXIMUM OPERATING PRESSURE : 3000 psi (SAFETY FACTOR = 2)

HYDRO CUSTOM IS NOT RESPONSIBLE FOR INCORRECT RESULTS OBTAINED WITH FIGURES IN THIS DOCUMENT. INFORMATION IS FOR REFERENCE ONLY. NO OTHER CONDITIONS ARE EXPRESSED OR IMPLIED.

PISTONS

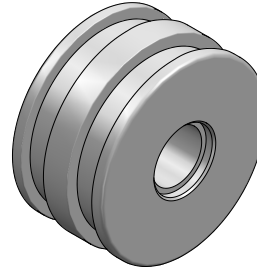
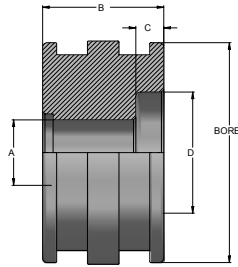

MODEL CODE	DIMENSIONS (IN)					
	BORE	ROD DIAMETER	A	B	C	D
ST-15062-PIP	1.50	1.00	0.62	1.50	-	-
ST-20075-PIP	2.00	1.25	0.75	1.50	-	-
ST-25087-PIP	2.50	1.50	0.87	1.62	0.37	1.62
ST-30087-PIP	3.00	1.50	0.87	1.62	0.37	1.62
ST-35100-PIP	3.50	1.75	1.00	1.62	0.43	1.87
ST-40125-PIP	4.00	2.00	1.25	1.75	0.68	2.62
ST-50150-PIP	5.00	2.50	1.50	2.50	0.62	3.25
ST-60200-PIP	6.00	3.00	2.00	2.50	0.62	3.62

MATERIAL : 65-45-12 DUCTILE CAST IRON
 PISTON FOR 5" & 6" BORE COME WITH A WEAR RING GROOVE

GLANDS

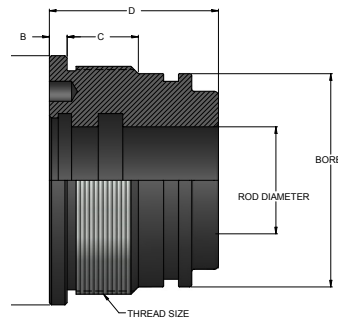

MODEL CODE	DIMENSIONS (IN)						THREAD
	BORE	ROD DIAMETER	A	B	C	D	
ST-15100-GLP	1.50	1.00	2.00	0.25	0.75	2.00	1.700-12 UN
ST-20125-GLP	2.00	1.25	2.50	0.25	0.87	2.25	2.200-12 UN
ST-25150-GLP	2.50	1.50	3.00	0.25	1.00	2.37	2.700-12 UN
ST-30150-GLP	3.00	1.50	3.50	0.25	1.00	2.37	3.200-12 UN
ST-35175-GLP	3.50	1.75	4.00	0.25	1.00	2.37	3.700-12 UN
ST-40200-GLP	4.00	2.00	4.50	0.25	1.00	2.37	4.200-12 UN
ST-50250-GLP	5.00	2.50	5.50	0.31	1.37	3.00	5.200-12 UN
ST-60300-GLP	6.00	3.00	6.75	0.50	1.56	3.50	6.250-12 UN

MATERIAL : 65-45-12 DUCTILE CAST IRON
 GLAND FOR 5" & 6" BORE COMES WITH A WEAR RING GROOVE

ROD BUSHINGS

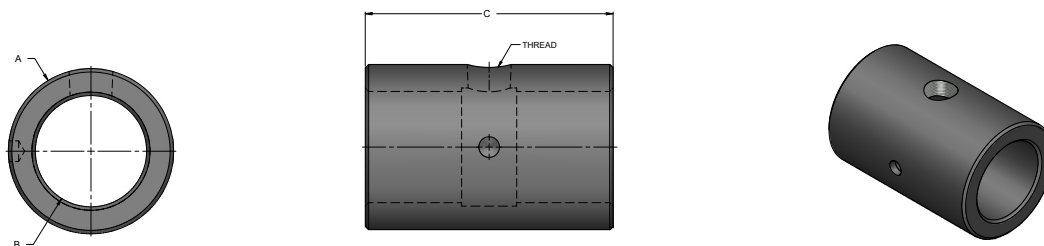

MODEL CODE	DIMENSIONS (IN)			THREAD	MAXIMUM LOAD PUSH / PULL (LBS)
	A	B	C		
BU-075200-BUP	1.25	0.76	2.00	1/8 NPT	5300
BU-100225-BUP	1.50	1.01	2.25	1/8 NPT	21200
BU-125225-BUP	2.00	1.26	2.25	1/8 NPT	29000
BU-150250-BUP	2.25	1.51	2.50	1/8 NPT	37700
BU-200325-BUP*	3.00	*2.01	3.25	1/8 NPT	59000

* COME WITH A SLEEVE TO PASS FROM 2" TO 1 3/4" PIN DIAMETER
 MAXIMUM PUSHING / PULLING FORCE ARE BASED ON A SUGGESTED MINIMUM SAFETY FACTOR OF 2
 MATERIAL : C1020 STEEL

END CAP BUSHINGS

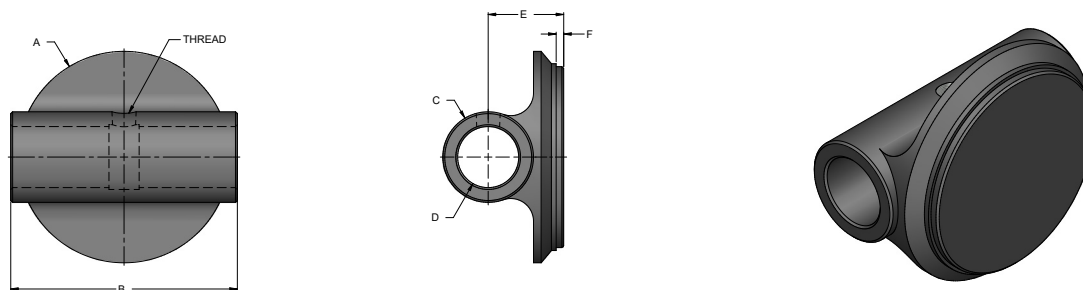

MODEL CODE	DIMENSIONS (IN)							THREAD	MAXIMUM LOAD PUSH / PULL (LBS)
	BORE	A	B	C	D	E	F		
BU-15075-CAP	1.50	2.00	2.25	1.25	0.76	1.12	0.12	1/8 NPT	5300
BU-20100-CAP	2.00	2.50	2.75	1.50	1.01	1.25	0.12	1/8 NPT	9500
BU-25100-CAP	2.50	3.00	3.25	1.50	1.01	1.25	0.12	1/8 NPT	14700
BU-30100-CAP	3.00	3.50	3.75	1.50	1.01	1.25	0.12	1/8 NPT	21200
BU-35125-CAP	3.50	4.00	4.25	2.00	1.26	1.50	0.12	1/8 NPT	29000
BU-40150-CAP	4.00	4.50	4.75	2.25	1.51	1.62	0.12	1/8 NPT	37700
BU-50200-CAP*	5.00	5.50	5.75	3.00	2.01	2.25	0.25	1/8 NPT	59000

* COME WITH A SLEEVE TO PASS FROM 2" TO 1 3/4" PIN DIAMETER
 MAXIMUM PUSHING / PULLING FORCE ARE BASED ON A SUGGESTED MINIMUM SAFETY FACTOR OF 2
 MATERIAL : C1045 CAST STEEL

END CAP CLEVIS

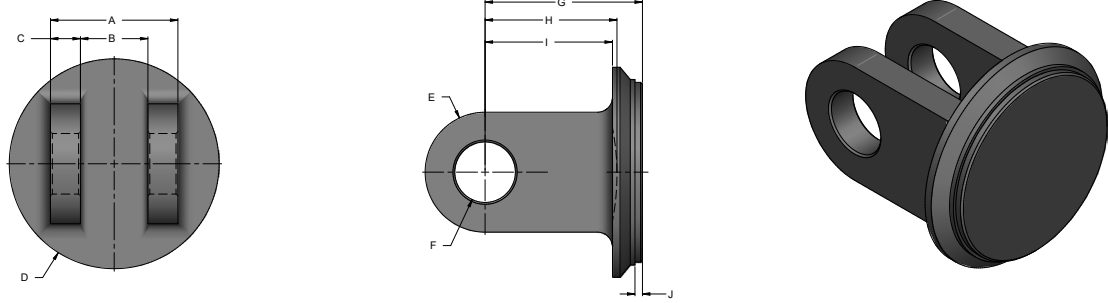

MODEL CODE	DIMENSIONS (IN)											MAXIMUM LOAD PUSH / PULL (LBS)
	BORE	A	B	C	D	E	F	G	H	I	J	
CL-15075-CAP	1.50	1.62	0.87	0.37	2.00	1.50	0.76	1.87	-	1.37	0.12	5300
CL-20100-CAP	2.00	2.12	1.12	0.50	2.50	2.00	1.01	2.62	-	2.12	0.12	9500
CL-25100-CAP	2.50	2.12	1.12	0.50	3.00	2.00	1.01	2.62	-	2.12	0.12	14750
CL-30100-CAP	3.00	2.12	1.12	0.50	3.50	2.00	1.01	2.62	-	2.12	0.12	22500
CL-35100-CAP	3.50	2.37	1.12	0.62	4.00	2.00	1.01	2.62	2.12	2.00	0.12	28100
CL-40100-CAP	4.00	2.37	1.12	0.62	4.50	2.00	1.01	2.50	2.00	1.75	0.12	28100
CL-50150-CAP	5.00	3.12	1.62	0.75	5.50	3.00	1.51	3.12	-	2.25	0.25	50600

MATERIAL : C1045 CAST STEEL
 MAXIMUM PUSHING / PULLING FORCE ARE BASED ON A SUGGESTED MINIMUM SAFETY FACTOR OF 2

PINS

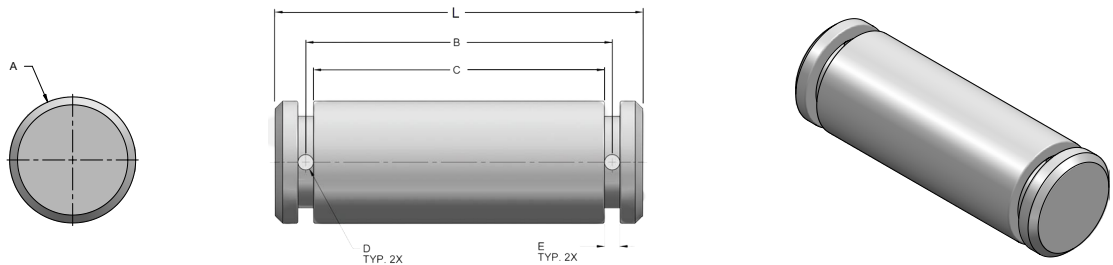

MODEL CODE	DIMENSIONS (IN)					MAXIMUM LOAD PUSH / PULL (LBS)	FOR MODELS
	A	B	C	D & E	C		
075175-PNP	0.750	1.87	1.75	0.12	2.38	15700	CL15, TCL15 CAP
075212-PNP	0.750	2.25	2.12	0.12	2.62	15700	TCL15 FRONT CLEVIS
100237-PNP	1.000	2.50	2.37	0.12	3.00	28100	CL20, CL25, CL30
100262-PNP	1.000	2.75	2.62	0.12	3.25	28100	CL35, CL40
100275-PNP	1.000	2.87	2.75	0.12	3.28	28100	TR2.5, TR3-20/25/30
100287-PNP	1.000	3.00	2.87	0.12	3.63	28100	TCL, TR3-35/40
125350-PNP	1.250	3.62	3.50	0.12	4.12	50500	TRxx-xx16-ASAE, TR3-50
150337-PNP	1.500	3.56	3.37	0.18	4.12	63100	CL50

MATERIAL : C1045 STEEL ZINC PLATED
 MAXIMUM PUSHING / PULLING FORCE ARE BASED ON A SUGGESTED MINIMUM SAFETY FACTOR OF 2

HYDRO CUSTOM IS NOT RESPONSIBLE FOR INCORRECT RESULTS OBTAINED WITH FIGURES IN THIS DOCUMENT. INFORMATION IS FOR REFERENCE ONLY. NO OTHER CONDITIONS ARE EXPRESSED OR IMPLIED.

BU & CL SERIES

MODEL CODE	DESCRIPTION
SK-BU-CL151000	1 1/2" BORE & 1" ROD
SK-BU-CL201250	2" BORE & 1 1/4" ROD
SK-BU-CL251500	2 1/2" BORE & 1 1/2" ROD
SK-BU-CL301500	3" BORE & 1 1/2" ROD
SK-BU-CL351750	3 1/2" BORE & 1 3/4" ROD
SK-BU-CL402000	4" BORE & 2" ROD
SK-BU-CL502500	5" BORE & 2 1/2" ROD

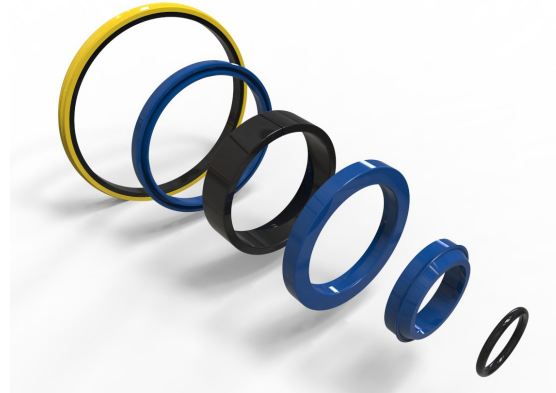

TR2.5 SERIES

MODEL CODE	DESCRIPTION
SK-TR3-201125	2" BORE & 1 1/8" ROD
SK-TR3-251250	2 1/2" BORE & 1 1/4" ROD
SK-TR3-301250	3" BORE & 1 1/4" ROD
SK-TR3-301500	3" BORE & 1 1/2" ROD
SK-TR3-351250	3 1/2" BORE & 1 1/4" ROD
SK-TR3-351500	3 1/2" BORE & 1 1/2" ROD
SK-TR3-401500	4" BORE & 1 1/2" ROD
SK-TR3-401750	4" BORE & 1 3/4" ROD
SK-TR3-402000	4" BORE & 2" ROD
SK-TR3-502000	5" BORE & 2" ROD

TR3 SERIES

MODEL CODE	DESCRIPTION
SK-TR3-201125	2" BORE & 1 1/8" ROD
SK-TR3-251250	2 1/2" BORE & 1 1/4" ROD
SK-TR3-301250	3" BORE & 1 1/4" ROD
SK-TR3-301500	3" BORE & 1 1/2" ROD
SK-TR3-351250	3 1/2" BORE & 1 1/4" ROD
SK-TR3-351500	3 1/2" BORE & 1 1/2" ROD
SK-TR3-401500	4" BORE & 1 1/2" ROD
SK-TR3-401750	4" BORE & 1 3/4" ROD
SK-TR3-402000	4" BORE & 2" ROD
SK-TR3-502000	5" BORE & 2" ROD

TCL SERIES

MODEL CODE	DESCRIPTION
SK-TCL-151000	1 1/2" BORE & 1" ROD
SK-TCL-201125	2" BORE & 1 1/8" ROD
SK-TCL-251250	2 1/2" BORE & 1 1/4" ROD
SK-TCL-301500	3" BORE & 1 1/2" ROD
SK-TCL-351750	3 1/2" BORE & 1 3/4" ROD
SK-TCL-402000	4" BORE & 2" ROD

WT3 SERIES

MODEL CODE	DESCRIPTION
SK-WT3-151000	1 1/2" BORE & 1" ROD
SK-WT3-201250	2" BORE & 1 1/4" ROD
SK-WT3-251375	2 1/2" BORE & 1 3/8" ROD
SK-WT3-301500	3" BORE & 1 1/2" ROD
SK-WT3-351750	3 1/2" BORE & 1 3/4" ROD
SK-WT3-402000	4" BORE & 2" ROD

NEW LINEAR TRANSDUCER EQUIPPED CYLINDER

HYDRO CUSTOM SERIES ARE DESIGNED SPECIFICALLY FOR MOBILE HYDRAULIC APPLICATION :

- LIVE CYLINDER POSITIONING FEEDBACK.
- ADAPTABLE TO THE NEW MECHATRONIC ENGINEERING.
- AVAILABLE WITH INTERNAL, EXTERNAL, AND PARALLEL DESIGN.
- HIGH VIBRATION/SHOCK RESISTANCE.
- PARALLEL SERIES CAN BE INTEGRATED TO EXISTING SYSTEMS.

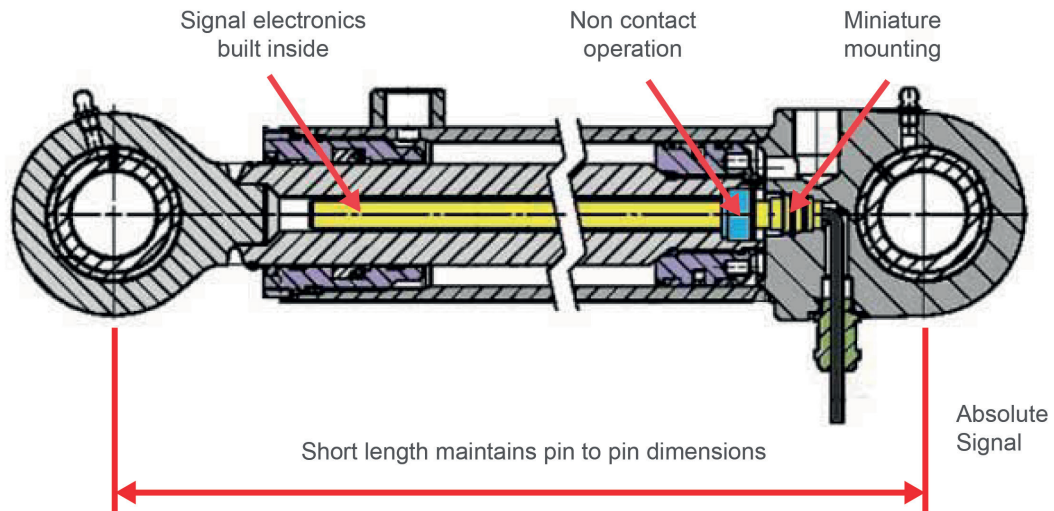

Analogue or digital outputs -
High cycling and vibration life

DESIGN, MANUFACTURING & QUALITY CONTROL

YOUR PARTNER TO MANUFACTURE HIGH-QUALITY HYDRAULIC CYLINDER FROM; 2 1/2 INCH. TO MORE THAN 25" BORE AND OUR MACHINERY CAN DO SUCH AS 24 FT. LONG CYLINDER.

WITH MORE THAN 25 YRS, IN BUSINESS AND A BRAND-NEW FACILITY OF 70,000 SFT. OF MANUFACTURING HYDROLICO INC. DIVISION CAN OFFER YOU MANY BENEFITS:

- AN EXPERIENCED AND QUALIFIED TEAM AS WELL AS ITS LEADING-EDGE PRODUCTION EQUIPMENT.
- EXPERIENCED ADVISORS IN DEVELOPMENT AND DESIGN.
- INNOVATIVE MANUFACTURING SOLUTIONS TAILORED TO THE NEEDS OF THE CLIENTS.
- CUSTOMIZED MANUFACTURING SOLUTIONS ADAPTED TO THE SPEED, QUANTITY AND DESIRED PRICE.
- A VARIETY OF SPECIALIZED SERVICES THAT CAN BE CUSTOMIZED TO YOUR NEEDS, INCLUDING VALIDATION OF 3D PROTOTYPES, REPEATED RIGOROUS TESTING, INSTALLATION AND ASSEMBLY IN A CONTAMINANT-FREE ENVIRONMENT.

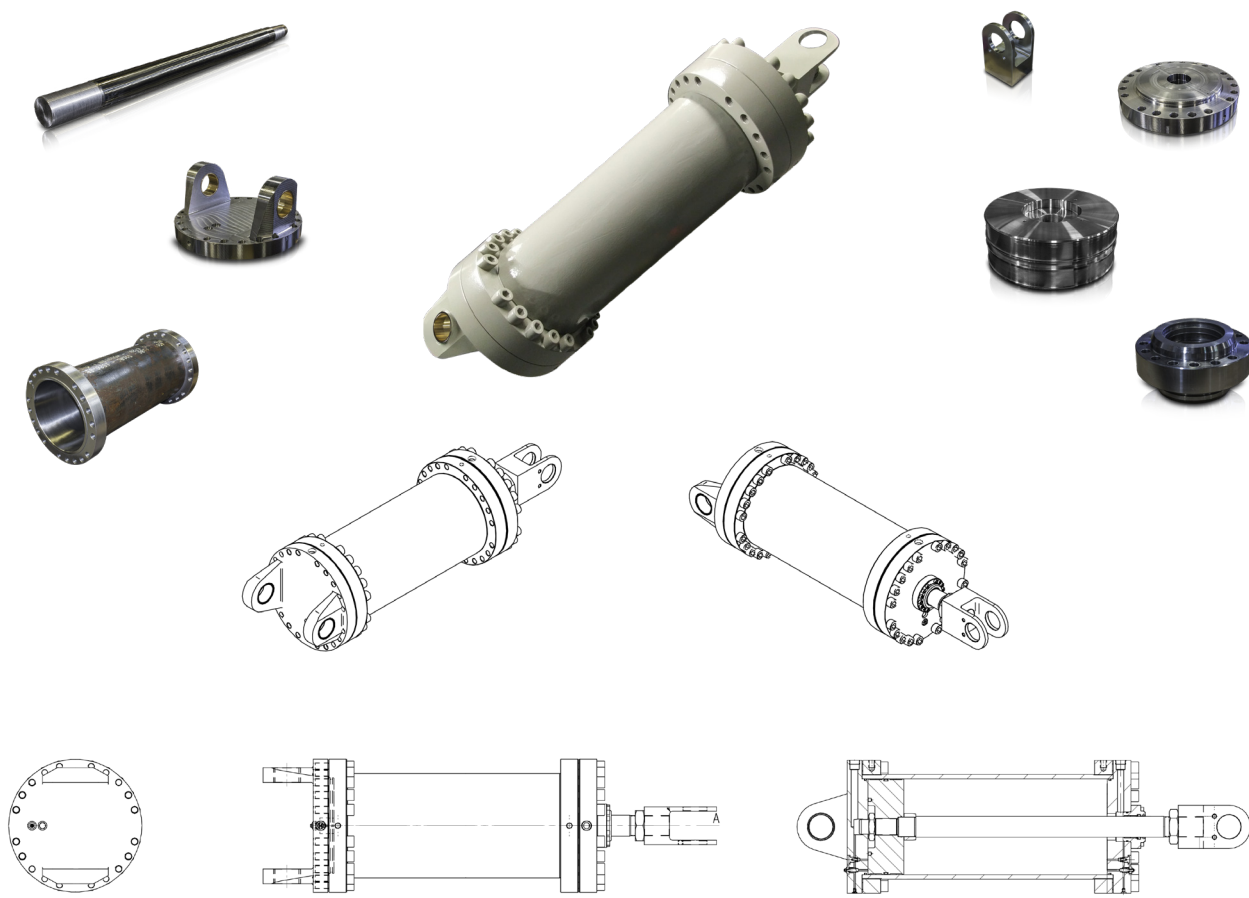

THE HYDRAULIC MOTORS HAVE AN ADVANTAGE OF SMALL VOLUME, HIGH EFFICIENCY, LOW NOISE, ETC. AND CAN BE USED IN A WIDE FIELD OF APPLICATION SUCH AS: CONSTRUCTION, AGRICULTURAL, PLASTIC, MINING, MATERIAL LIFTING, FORESTRY, LAWN AND TURF, MACHINE TOOLS AND STATIONARY, MARINE, ETC.



BMM
UP TO 1950 RPM
UP TO 407 LB-IN

BMM IS A MINI-MOTOR WITH HIGH SPEED CAPABILITIES.

P.39



BM1
UP TO 879 RPM
UP TO 3845 LB-IN

BM1 IS A SMALL VOLUME, SPOOL VALVE TYPE MOTOR, WITH OPTIONAL SIDE LOAD BEARING DESIGN. AVAILABLE IN H (EATON) AND S (DANFOSS) PORT CONFIGURATION. HIGH PRESSURE SHAFT SEAL UP TO 2900 PSI AVAILABLE.

P.40



BM2 / BM2W
UP TO 755 RPM
UP TO 5613 LB-IN

BM2 IS A MEDIUM VOLUME, SPOOL VALVE TYPE MOTOR, WITH OPTIONAL SIDE LOAD BEARING DESIGN. AVAILABLE IN H (EATON) AND S (DANFOSS) PORT CONFIGURATION. HIGH PRESSURE SHAFT SEAL UP TO 2900 PSI AVAILABLE.

BM2W WHEEL MOTOR IS A RECESSED MOUNTING FLANGE, WITH RADIAL BEARING DESIGN, WHICH CAN BEAR A GREATER LOAD. HIGH PRESSURE SHAFT SEAL UP TO 2900 PSI AVAILABLE.

P.42

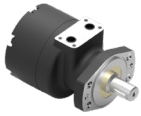

BME
UP TO 336 RPM
UP TO 9824 LB-IN

BME MOTOR HAS ADVANCED GEROLER GEAR SET DESIGN, THEY ARE SUITED FOR HIGH PRESSURE HIGH EFFICIENCY, LOW SPEED APPLICATIONS. IT CAN KEEP HIGH VOLUME EFFICIENCY, LONG WORKING LIFE. HIGH PRESSURE SHAFT SEAL UP TO 2900 PSI AVAILABLE.

P.44



BM5 / BM5S
UP TO 799 RPM
UP TO 6370 LB-IN

BM5 IS A LARGE VOLUME, DISC VALVE, HIGH PRESSURE MOTOR, WITH RADIAL BALL-BEARINGS DESIGN AND CAN BEAR GREATER LOAD. HIGH PRESSURE SHAFT SEAL UP TO 2900 PSI AVAILABLE.

BM5S BEARINGLESS MOTOR IS A SHORT MOTOR DESIGN WITHOUT BEARINGS, FOR GEARBOX ASSEMBLY APPLICATIONS.

P.46



BMT
UP TO 12958 LB-IN

BMT IS OUR LARGEST VOLUME DISC VALVE HIGH PRESSURE MOTOR WITH RADIAL BALL-BEARINGS DESIGN WHICH CAN BEAR GREATER LOAD AND IS SHORTER THAN OUR **BM6**.

P.48



BM6
UP TO 775 RPM
UP TO 3852 LB-IN

BM6 IS A LARGE VOLUME, DISC VALVE, HIGH PRESSURE MOTOR, WITH RADIAL BALL-BEARINGS DESIGN AND CAN BEAR GREATER LOAD, AND HAS HIGHER TORQUE CAPABILITIES THAN OUR **BM5**.

P.49



BMV
UP TO 17813 LB-IN

BMV IS A DISC VALVE, HIGH PRESSURE MOTOR, WITH RADIAL BALL-BEARINGS DESIGN AND EFFICIENT PERFORMANCE WHICH CAN BEAR GREATER LOAD THAN **BMT**. ITS FIGURATION IS BIGGER THAN **BMT**.

P.50

BMM SERIES MOTOR IS A MINI-MOTOR WITH HIGH SPEED, VERY COMPACT DESIGN, SPOOL VALVE, ECONOMICAL TYPE MOTOR.

CHARACTERISTIC FEATURES

- * COMPACT DESIGN OF SPOOL AND GEAR SET, WHICH PROVIDE MINI VOLUME, HIGH POWER DENSITY AND LOW WEIGHT
- * CREDIBLE DESIGN FOR SHAFT SEAL, WHICH CAN BEAR HIGH PRESSURE AND BE USED IN PARALLEL OR IN SERIES
- * DIRECTION OF SHAFT ROTATION AND SPEED CAN BE CONTROLLED EASILY AND SMOOTHLY



DISPLACEMENT IN ³ (CM ³) / REV.		0.5 (8.2)	0.79 (12.9)	1.21 (19.9)	1.93 (31.6)	3.0 (50.3)
FLOW (GPM)	CONT.	4.2	5.2	5.2	5.2	5.2
	INT.	5.2	6.6	6.6	6.6	6.6
SPEED (RPM)	CONT.	1950	1550	1000	630	400
	INT.	2450	1940	1250	800	500
PRESSURE (PSI)	CONT.	1450	1450	1450	1450	1015
	INT.	2030	2030	2030	2030	2030
TORQUE (LB-IN)	CONT.	97	141	221	354	407
	INT.	132	203	309	504	778
LENGTH (IN)	L1	4.09	4.17	4.29	4.45	4.80
	L2	4.13	4.21	4.33	4.53	4.84
	L3	0.14	0.22	0.34	0.53	0.85

OTHER SHAFTS & MOUNTINGS AVAILABLE UPON REQUEST

SIDE PORT

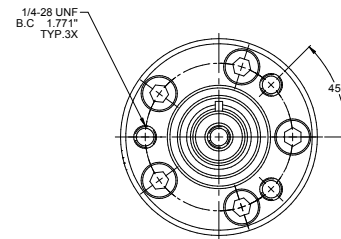
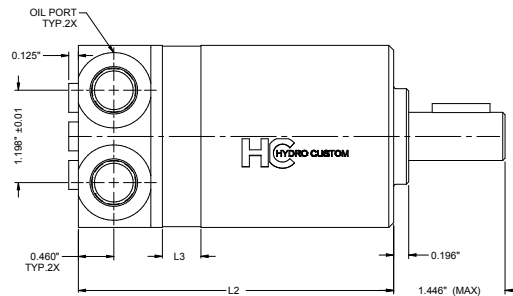
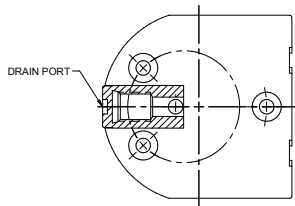

REAR PORT

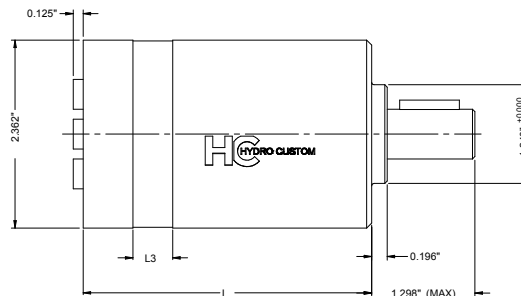
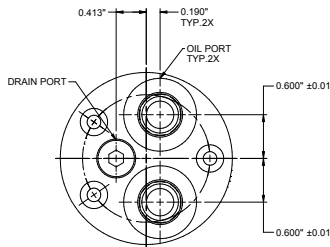

MODEL CODES

PORT CONFIGURATION	0.5 (8.2)	0.79 (12.9)	1.21 (19.9)	1.93 (31.6)	3.0 (50)
SIDE PORT	301-0050	301-0051	301-0052	301-0053	301-0055
REAR PORT	301-0060	301-0061	301-0062	301-0063	301-0065

BM1 SERIES MOTOR IS A SMALL VOLUME, SPOOL VALVE GEROLOR GEAR SET, ECONOMICAL TYPE MOTOR

CHARACTERISTIC FEATURES

- COMPACT DESIGN OF SPOOL AND GEAR SET, WHICH PROVIDE SMALL VOLUME, HIGH POWER AND LOW WEIGHT
- DIRECTION OF SHAFT ROTATION AND SPEED CAN BE CONTROLLED EASILY AND SMOOTHLY
- BEST COMBINATION OF EFFICIENCY AND ECONOMY IN MEDIUM LOAD APPLICATIONS
- STANDARD SHAFT SEALS RATED AT 1900 PSI
- NEW, ON MANY SERIES, HIGH PRESSURE SHAFT SEALS UP TO 2900 PSI, AVAILABLE UPON REQUEST



MAIN SPECIFICATIONS

DISPLACEMENT IN ³ (CM ³) / REV.		3.0 (50)	4.8 (80)	6.1 (100)	7.6 (125)	9.7 (160)	12.2 (200)	15.2 (250)	19.2 (315)	24.4 (400)
FLOW (GPM)	CONT.	12	12	15	15	15	15	15	15	15
	INT.	14.5	14.5	20	20	20	20	20	20	20
SPEED (RPM)	CONT.	716	750	550	450	360	280	220	189	140
	INT.	955	900	673	560	430	350	270	236	180
PRESSURE (PSI)	CONT.	2030	2030	2030	2030	2030	2030	1595	1305	1015
	INT.	2537	2537	2537	2537	2537	2537	2030	2030	1522
TORQUE (LB-IN)	CONT.	734	1140	1423	1812	2166	2519	3182	3589	3845
	INT.	955	1503	1874	2343	3014	3448	4022	4464	4694
	PEAK	1014	1630	1990	2681	3441	3967	4113	4885	4922
LENGTH (IN)	L	0.35	0.57	0.70	0.91	1.14	1.46	1.81	2.24	2.84
	L1	5.63	5.81	5.95	6.14	6.38	6.69	7.07	7.50	8.07
	L2	5.83	6	6.14	6.34	6.58	6.89	7.26	7.70	8.27

- NOTES**
1. CONTINUOUS DATA: THE MAX. VALUE OF OPERATING MOTOR CONTINUOUSLY.
 2. INTERMITTENT DATA: THE MAX. VALUE OF OPERATING MOTOR IS 10 % PER MINUTE.
 3. A SIMULTANEOUS MAX. RPM AND MAX. PRESSURE IS NOT RECOMMENDED.
 4. OPTIMUM OPERATING SITUATION SHOULD BE AT THE 1/3-2/3 OF THE CONTINUOUS OPERATION.

MODEL CODES

TYPE H PORT CONFIGURATION - SIDE LOAD BEARING OPTION

FLANGE	SHAFT	PORT SIZE	3.0 (50)	4.8 (80)	6.1 (100)	7.6 (125)	9.7 (160)	12.2 (200)	15.2 (250)	19.2 (315)	24.4 (400)
2 BOLT	1" STRAIGHT	SAE-10	316-0400H	316-0402H	316-0403H	316-0409H	316-0404H	316-0405H	316-0406H	316-0408H	316-0407H
		1/2 NPT	316-0390H	316-0392H	316-0393H	316-0399H	316-0394H	316-0395H	316-0396H	316-0398H	316-0397H
	1"-6T SPLINE	SAE-10	316-0800H	316-0802H	316-0803H	316-0809H	316-0804H	316-0805H	316-0806H	316-0808H	316-0807H
		1/2 NPT	316-0820H	316-0822H	316-0823H	316-0829H	316-0824H	316-0825H	316-0826H	316-0828H	316-0827H
4 BOLT	1" STRAIGHT	SAE-10	316-0500H	316-0502H	316-0503H	316-0509H	316-0504H	316-0505H	316-0506H	316-0508H	316-0507H
		1/2 NPT	316-0420H	316-0422H	316-0423H	316-0429H	316-0424H	316-0425H	316-0426H	316-0428H	316-0427H
	1"-6T SPLINE	SAE-10	316-0900H	316-0902H	316-0903H	316-0909H	316-0904H	316-0905H	316-0906H	316-0908H	316-0907H
		1/2 NPT	316-0920H	316-0922H	316-0923H	316-0929H	316-0924H	316-0925H	316-0926H	316-0928H	316-0927H

TYPE S PORT CONFIGURATION

FLANGE	SHAFT	PORT SIZE	3.0 (50)	4.8 (80)	6.1 (100)	7.6 (125)	9.7 (160)	12.2 (200)	15.2 (250)	19.2 (315)	24.4 (400)
2 BOLT	1" STRAIGHT	SAE-10	313-0400	313-0402	313-0403	313-0409	313-0404	313-0405	313-0406	313-0408	313-0407
		1/2 NPT	313-0390	313-0392	313-0393	313-0399	313-0394	313-0395	313-0396	313-0398	313-0397
	1"-6T SPLINE	SAE-10	313-0800	313-0802	313-0803	313-0809	313-0804	313-0805	313-0806	313-0808	313-0807
		1/2 NPT	313-1270	313-1272	313-1273	313-1279	313-1274	313-1275	313-1276	313-1278	313-1277
4 BOLT	1" STRAIGHT	SAE-10	313-0500	313-0502	313-0503	313-0509	313-0504	313-0505	313-0506	313-0508	313-0507
		1/2 NPT	313-0420	313-0422	313-0423	313-0429	313-0424	313-0425	313-0426	313-0428	313-0427
	1"-6T SPLINE	SAE-10	313-0900	313-0902	313-0903	313-0909	313-0904	313-0905	313-0906	313-0908	313-0907
		1/2 NPT	313-0920	313-0922	313-0923	313-0929	313-0924	313-0925	313-0926	313-0928	313-0927
4 BOLT + BEARING	1" STRAIGHT	SAE-10	317-0250	317-0252	317-0253	317-0259	317-0254	317-0255	317-0256	317-0258	317-0257

DIMENSIONS

H TYPE

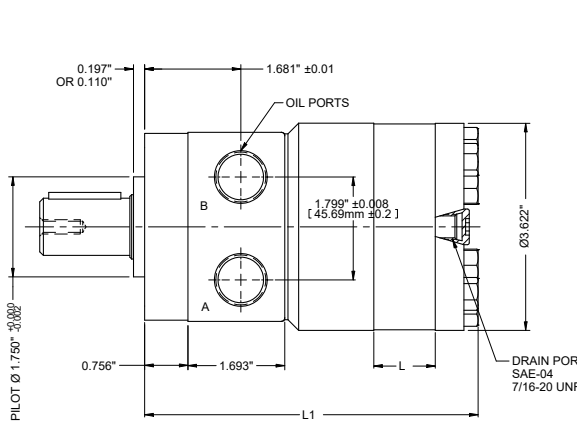

S TYPE

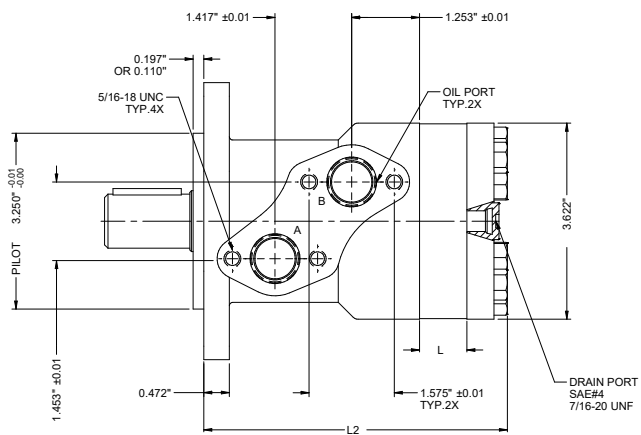

4 BOLT

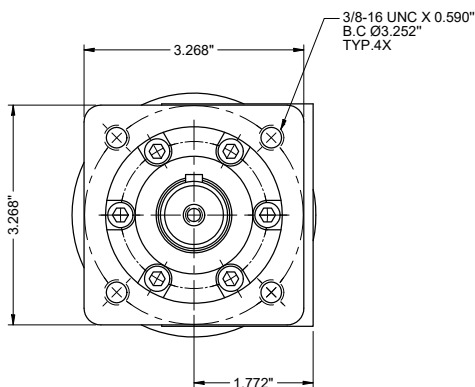

SQUARE FLANGE
4X 3/8-16 UNC BOLT ON Ø3.25"

2 BOLT

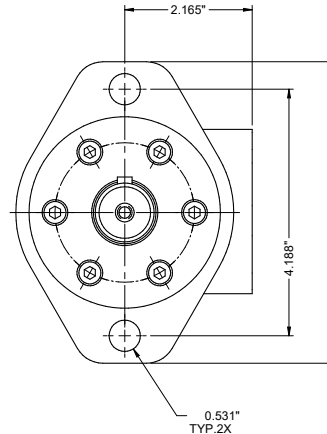

2 BOLTS FLANGE, Ø0.531\"X2
BOLT CENTER SPACE 4.188\"
PILOT Ø3.250\" X 0.197\""

SHAFTS

1\" STRAIGHT KEY

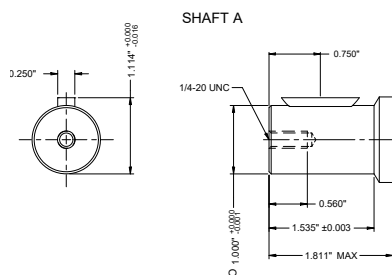

CYLINDER SHAFT : 1\" X 1.535\"
WOODRUFF KEY : 1\" X 0.250\"
LINK THREAD : 1/4-20 UNC

1\"- 6T SPLINE

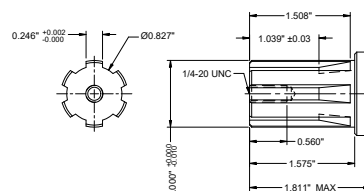

SPLINE SHAFT : 0.996\" X 1.535\"
0.996\" X 0.846\" X 0.246\" 6
TEETH LINK THREAD: 1/4-20 UN C

BM2 / BM2W SERIES MOTOR IS A MEDIUM, SPOOL VALVE TYPE MOTOR, THAT CAN BEAR HIGHER PRESSURE THAN BM1.

CHARACTERISTIC FEATURES

- IT ADOPTS THE GEROLOR DESIGN
- HAS HIGHER EFFICIENCY THAN OUR BM1 SERIES
- CREDIBLE DESIGN FOR SHAFT SEAL, WHICH CAN BEAR HIGH PRESSURE AND CAN BE USED IN PARALLEL OR IN SERIES APPLICATION
- DIRECTION OF SHAFT SPEED CAN BE CONTROLLED EASILY AND SMOOTHLY
- BEST EFFICIENCY AND ECONOMY IN MEDIUM LOAD APPLICATIONS
- STANDARD SHAFT SEALS RATED AT 1987 PSI
- NEW, ON MANY SERIES, HIGH PRESSURE SHAFT SEALS UP TO 2900 PSI



BM2



BM2W

MAIN SPECIFICATIONS

DISPLACEMENT IN ³ (CM ³) / REV.		3.0 (50)	4.8 (80)	6.1 (100)	7.6 (125)	9.7 (160)	12.2 (200)	15.2 (250)	19.2 (315)	24.4 (400)	30.4 (500)
FLOW (GPM)	CONT.	10.5	15.8	15.8	15.8	15.8	15.8	15.8	15.8	15.8	15.8
	INT.	13.2	20	20	20	20	20	20	20	20	20
SPEED (RPM)	CONT.	755	750	600	475	375	300	240	190	160	110
	INT.	970	940	750	600	470	375	300	240	200	128
PRESSURE (PSI)	CONT.	2030	2030	2030	2030	2392	1885	1595	1235	1235	1160
	INT.	2537	2900	2900	2900	2900	2900	2900	1667	1667	1305
TORQUE (LB-IN)	CONT.	884	1414	1759	2210	2829	2917	3403	3403	4287	5613
	INT.	1105	1680	2122	2581	3359	3960	4844	4880	5923	6674
LENGTH (IN)	L	0.35	0.57	0.70	0.91	1.14	1.46	1.81	2.24	2.84	3.54
	L1	5.75	5.97	6.09	6.30	6.54	6.85	7.21	7.64	8.23	8.94
	L2	5.95	6.16	6.29	6.50	6.73	7.05	7.40	7.84	8.43	9.13
	L3	6.18	6.42	6.54	6.73	6.99	7.28	7.64	8.07	8.66	9.37

- NOTES**
1. CONTINUOUS DATA: THE MAX. VALUE OF OPERATING MOTOR CONTINUOUSLY.
 2. INTERMITTENT DATA: THE MAX. VALUE OF OPERATING MOTOR IS 10 % PER MINUTE.
 3. A SIMULTANEOUS MAX. RPM AND MAX. PRESSURE IS NOT RECOMMENDED.
 4. OPTIMUM OPERATING SITUATION SHOULD BE AT THE 1/3~2/3 OF THE CONTINUOUS OPERATION.

MODEL CODES

TYPE H PORT CONFIGURATION - SIDE LOAD BEARING OPTION

FLANGE	SHAFT	PORT SIZE	3.0 (50)	4.8 (80)	6.1 (100)	7.6 (125)	9.7 (160)	12.2 (200)	15.2 (250)	19.2 (315)	24.4 (400)	30.4 (500)
2 BOLT	1" KEY	SAE-10	323-0300H	323-0302H	323-0303H	323-030AH	323-0304H	323-0305H	323-0306H	323-0307H	323-0308H	323-0309H
4 BOLT	1" KEY	SAE-10	323-0400H	323-0402H	323-0403H	323-040AH	323-0404H	323-0405H	323-0406H	323-0407H	323-0408H	323-0409H

TYPE H PORT CONFIGURATION - SIDE LOAD BEARING + HIGH PRESSURE SHAFT SEAL OPTIONS

FLANGE	SHAFT	PORT SIZE	3.0 (50)	4.8 (80)	6.1 (100)	7.6 (125)	9.7 (160)	12.2 (200)	15.2 (250)	19.2 (315)	24.4 (400)	30.4 (500)
2 BOLT	1" KEY	SAE-10	523-0300H	523-0302H	523-0303H	523-030AH	523-0304H	523-0305H	523-0306H	523-0307H	523-0308H	523-0309H
4 BOLT	1" KEY	SAE-10	523-0400H	523-0402H	523-0403H	523-040AH	523-0404H	523-0405H	523-0406H	523-0407H	523-0408H	523-0409H

TYPE S PORT CONFIGURATION

FLANGE	SHAFT	PORT SIZE	3.0 (50)	4.8 (80)	6.1 (100)	7.6 (125)	9.7 (160)	12.2 (200)	15.2 (250)	19.2 (315)	24.4 (400)	30.4 (500)
2 BOLT	1" KEY	SAE-10	322-0300	322-0302	322-0303	322-030A	322-0304	322-0305	322-0306	322-0307	322-0308	322-0309
		1/2 NPT	322-0180	322-0182	322-0183	322-018A	322-0184	322-0185	322-0186	322-0187	322-0188	322-0189
4 BOLT	1" KEY	SAE-10	322-0250	322-0252	322-0253	322-025A	322-0254	322-0255	322-0256	322-0257	322-0258	322-0259
		1/2 NPT	322-0390	322-0392	322-0393	322-039A	322-0394	322-0395	322-0396	322-0397	322-0398	322-0399

SIDE LOAD BEARING AND HIGH PRESSURE SHAFT SEALS OPTION ALSO AVAILABLE

WHEEL MOTOR CONFIGURATION

FLANGE	SHAFT	PORT SIZE	3.0 (50)	4.8 (80)	6.1 (100)	7.6 (125)	9.7 (160)	12.2 (200)	15.2 (250)	19.2 (315)	24.4 (400)	30.4 (500)
WHEEL	1 1/4" TAPER	SAE-10	328-0420F	328-0422F	328-0423F	328-042AF	328-0424F	328-0425F	328-0426F	328-0427F	328-0428F	328-0429F

SIDE LOAD BEARING AND HIGH PRESSURE SHAFT SEALS OPTION ALSO AVAILABLE

DIMENSIONS

H TYPE

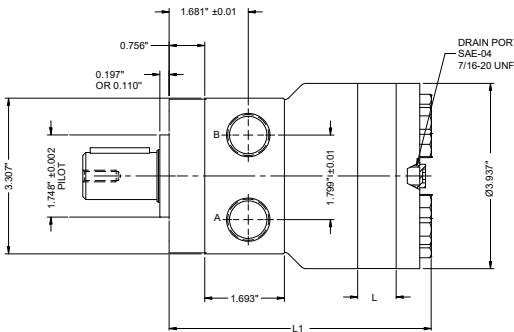

S TYPE

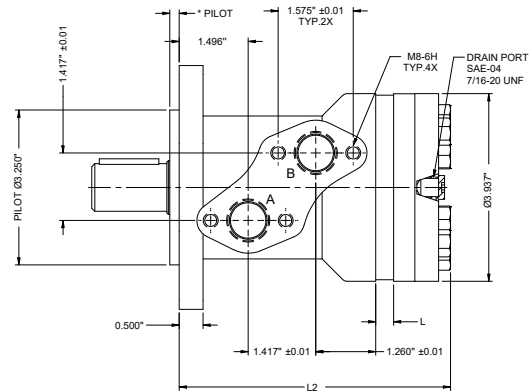

4 BOLT

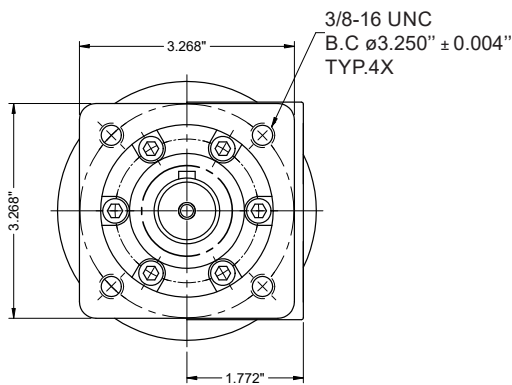

SQUARE FLANGE
4X 3/8-16 UNC BOLT ON Ø3.25"

2 BOLT

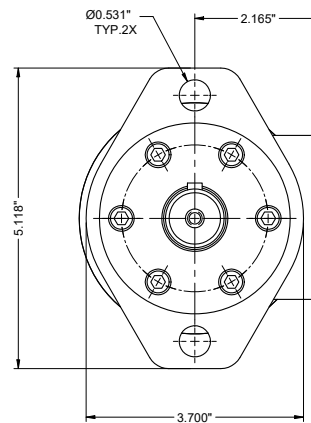

2 BOLTS FLANGE, Ø0.531" X 2 BOLT CENTER SPACE 4.188"
PILOT Ø3.250" X 0.197"

SHAFTS

1" KEY

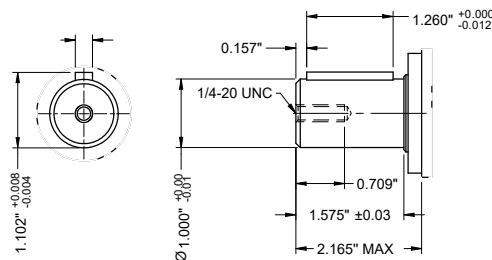

BM2W / 1 1/4" TAPER

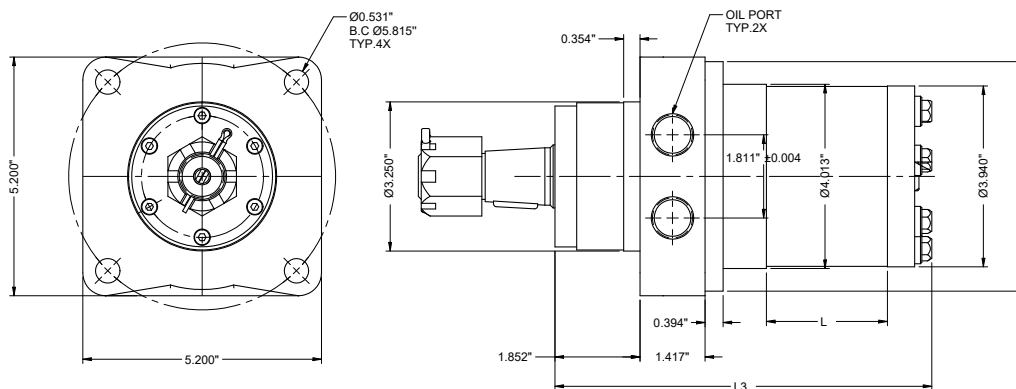

BME SERIES MOTOR HAS ADVANCED GEROLER GEAR SET DESIGN, THEY ARE SUITED FOR HIGH PRESSURE HIGH EFFICIENCY, LOW SPEED APPLICATIONS. IT CAN KEEP HIGH VOLUME EFFICIENCY, LONG WORKING LIFE.

CHARACTERISTIC FEATURES

- ADVANCED GEROLER GEAR SET DESIGN, LOW PRESSURE OF START-UP, HIGH EFFICIENCY
- HIGH PRESSURE APPLICATIONS, HIGH TORQUE. HAS NEEDLE BEARINGS DESIGN, IT CAN BEAR HIGH AXIAL AND RADIAL FORCES
- ADVANCE HIGH SPEED DISTRIBUTION FLOW DESIGN, AUTOMATICALLY COMPENSATE IN OPERATING, HIGH VOLUME EFFICIENCY, RUN SMOOTHLY AT LOW SPEED
- STANDARD SHAFT SEALS RATED AT 1900 PSI
- NEW, ON MANY SERIES, HIGH PRESSURE SHAFT SEALS UP TO 2900 PSI

BMEW WHEEL MOUNT



BME 6 HOLES MAGNETO



MAIN SPECIFICATIONS

DISPLACEMENT IN ³ (CM ³) / REV.		7.75 (125)	9.94 (160)	12.20 (200)	15.80 (250)	18.00 (300)	22.70 (375)	28.86 (475)	32.95 (540)	45.46 (750)
FLOW (GPM)	CONT.	11.89	15.85	18.49	19.81	21.13	19.81	19.81	19.81	19.81
	INT.	15.85	19.81	22.45	23.78	25.10	23.78	23.78	23.78	23.78
SPEED (RPM)	CONT.	336	350	330	290	250	200	150	140	100
	INT.	450	440	425	350	315	240	180	170	120
PRESSURE (PSI)	CONT.	2973	2973	2973	2973	2973	2973	2538	2030.5	1523
	INT.	3480	3480	3480	3480	3480	3480	2756	2538	1740
TORQUE (LB-IN)	CONT.	3088	4159	4708	6195	7169	8762	9824	8673	9293
	INT.	3611	4850	5328	6992	8231	10089	10691	10974	10443
LENGTH (IN)	L	6.06	6.22	6.33	6.53	6.69	6.93	185	7.28	8.22
	L1	4.43	4.56	4.69	4.89	5.02	5.29	5.64	5.87	6.66

- NOTE:**
1. CONTINUOUS DATA: THE MAX. VALUE OF OPERATING MOTOR CONTINUOUSLY.
 2. INTERMITTENT DATA: THE MAX. VALUE OF OPERATING MOTOR IN 6 SECONDS PER MINUTE.
 3. A SIMULTANEOUS MAX. RPM AND MAX. PRESSURE IS NOT RECOMMENDED.
 4. OPTIMUM OPERATING SITUATION SHOULD BE AT THE 1/3-2/3 OF THE CONTINUOUS OPERATING SITUATION.

MODEL CODES

FLANGE	SHAFT	7.75 (125)	9.94 (160)	12.20 (200)	15.80 (250)	18.00 (300)	22.70 (375)	28.86 (475)	32.95 (540)	45.46 (750)
MAGNETO MOUNT	1 1/4" STRAIGHT	392-0020F	392-0021F	392-0022F	392-0023F	392-0024F	392-0026F	392-0027F	392-0028F	392-0029F
	1 1/4" SPLINE	392-2020F	392-2021F	392-2022F	392-2023F	392-2024F	392-2026F	392-2027F	392-2028F	392-2029F
	1" STRAIGHT	392-0050F	392-0051F	392-0052F	392-0053F	392-0054F	392-0056F	392-0057F	392-0058F	392-0059F
	1" SPLINE	392-1000F	392-1001F	392-1002F	392-1003F	392-1004F	392-1006F	392-1007F	392-1008F	392-1009F
WHEEL MOTOR	1 1/4" TAPER	392-3000F	392-3001F	392-3002F	392-3003F	392-3004F	392-3006F	392-3007F	392-3008F	392-3009F
	1 1/4" STRAIGHT	392-3020F	392-3021F	392-3022F	392-3023F	392-3024F	392-3026F	392-3027F	392-3028F	392-3029F
	1 1/4" SPLINE	392-2030F	392-2031F	392-2032F	392-2033F	392-2034F	392-2036F	392-2037F	392-2038F	392-2039F

ALSO AVAILABLE:

- OTHER SHAFT DIMENSIONS
- OTHER MOUNTING FLANGES

DIMENSIONS

MAGNETO - 6 BOLT

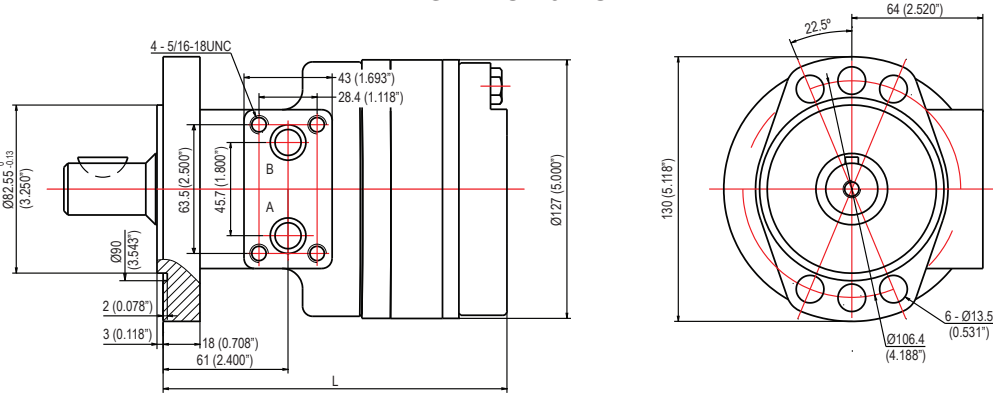

BMEW WHEEL MOUNT

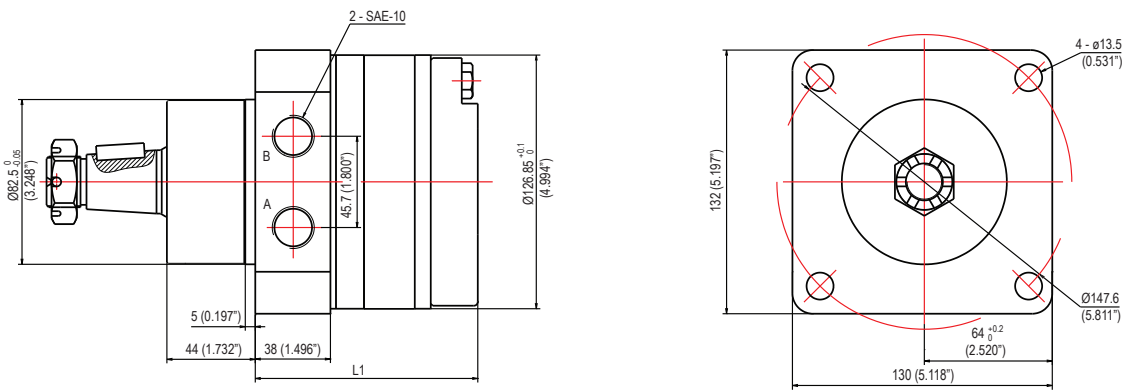

SHAFTS

1 1/4" STRAIGHT KEY

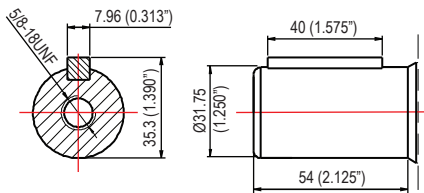

1 1/4"-14T SPLINE

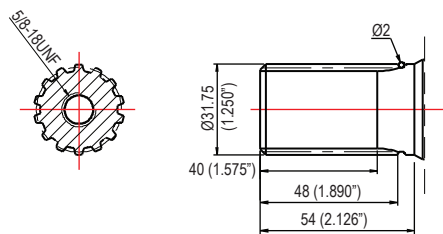

1" STRAIGHT KEY

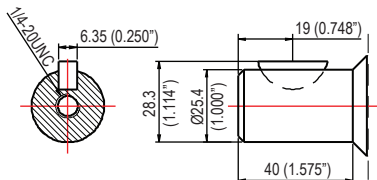

1 1/4" TAPER

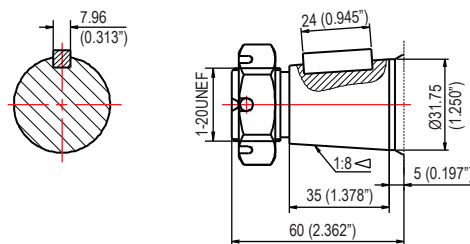

BM5 IS A LARGE VOLUME, DISC VALVE, HIGH PRESSURE MOTOR WITH RADIAL BEARINGS DESIGN AND CAN BEAR GREATER LOAD.

- HIGH PRESSURE SHAFT SEAL UP TO 2900 PSI AVAILABLE



MAIN SPECIFICATIONS

DISPLACEMENT IN ³ (CM ³) / REV.		4.8 (80)	6.1 (100)	7.6 (125)	9.7 (160)	12.2 (200)	15.2 (250)	18.6 (305)	24.4 (400)	30.4 (500)
FLOW (GPM)	CONT.	20	20	20	20	20	20	20	20	20
	INT.	22	25	25	30	30	30	30	30	30
SPEED (RPM)	CONT.	799	742	576	460	365	294	246	183	148
	INT.	908	924	720	713	577	462	365	287	230
PRESSURE (PSI)	CONT.	2980	3045	3045	3045	3045	2900	2900	2320	1740
	INT.	4350	4350	4350	3770	3770	3770	3480	2465	2030
	PEAK	4350	4350	4350	4350	4350	4350	4350	2900	2465
TORQUE (LB-IN)	CONT.	2033	2564	3182	4058	4791	5658	5967	7337	7470
	INT.	2555	3359	4243	4685	5622	6895	6851	8044	8398
	PEAK	2917	3713	4774	4818	5834	7205	8212	8840	9061
LENGTH (IN)	L	0.59	0.73	0.90	1.14	1.41	1.77	2.20	2.83	3.56
	L3	7.08	7.22	7.40	7.64	7.91	8.27	8.70	9.33	10.25

- NOTES**
1. CONTINUOUS DATA: THE MAX. VALUE OF OPERATING MOTOR CONTINUOUSLY.
 2. INTERMITTENT DATA: THE MAX. VALUE OF OPERATING MOTOR IS 10 % PER MINUTE.
 3. A SIMULTANEOUS MAX. RPM AND MAX. PRESSURE IS NOT RECOMMENDED.
 4. OPTIMUM OPERATING SITUATION SHOULD BE AT THE 1/3-2/3 OF THE CONTINUOUS OPERATION.

MODEL CODES

FLANGE	SHAFT	4.8 (80)	6.1 (100)	7.6 (125)	9.7 (160)	12.2 (200)	15.2 (250)	18.6 (305)	24.4 (400)	30.4 (500)
SAE-A 4 BOLT	1 1/4" STRAIGHT	351-0571	351-0572	351-0573	351-0574	351-0575	351-0576	351-0577	351-0578	351-0570
	1 1/4" SPLINE	351-2031	351-2032	351-2033	351-2034	351-2035	351-2036	351-2037	351-2038	351-2030
	1" STRAIGHT	351-0581	351-0582	351-0583	351-0584	351-0585	351-0586	351-0587	351-0588	351-0580
	1" SPLINE	351-1301G	351-1302G	351-1303G	351-1304G	351-1305G	351-1306G	351-1307G	351-1308G	351-1300G
MAGNETO MOUNT	1 1/4" STRAIGHT	351-0211	351-0212	351-0213	351-0214	351-0215	351-0216	351-0217	351-0218	351-0210
	1 1/4" SPLINE	351-2111	351-2112	351-2113	351-2114	351-2115	351-2116	351-2117	351-2118	351-2110
WHEEL MOTOR	1 1/4" TAPER	351-3141	351-3142	351-3143	351-3144	351-3145	351-3146	351-3147	351-3148	351-3140

ALSO AVAILABLE:

- OTHER SHAFT DIMENSIONS
- OTHER MOUNTING FLANGES

DIMENSIONS

BM5

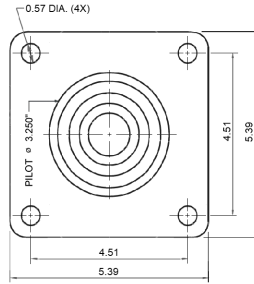
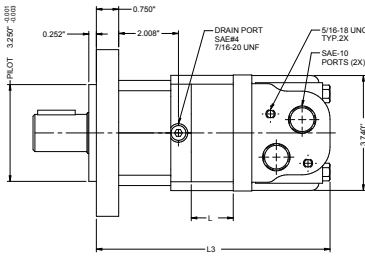

BM5W

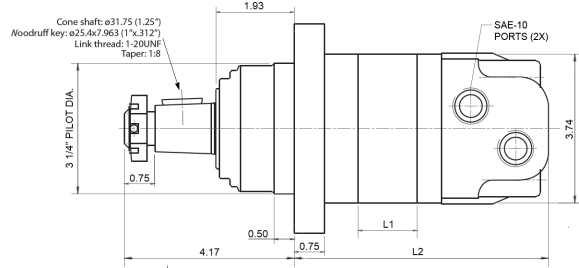

MOUNTING FLANGES

SAE A - 4 BOLT

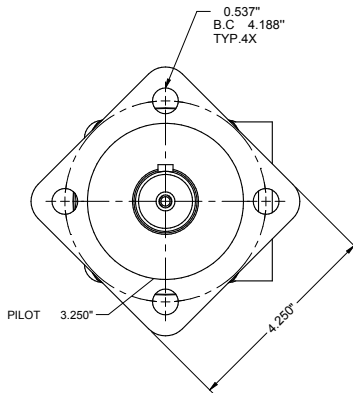

MAGNETO - 6 BOLT

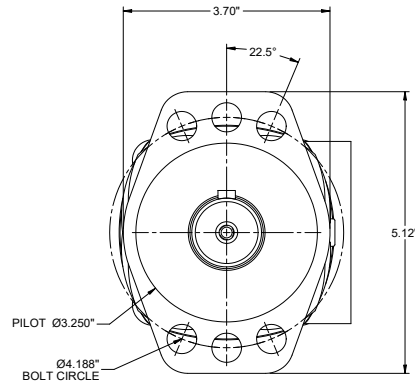

SHAFTS

1 1/4" STRAIGHT KEY

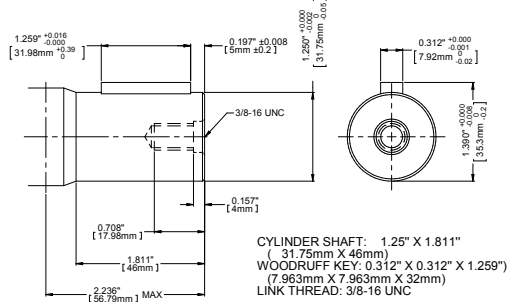

1 1/4"-14T SPLINED

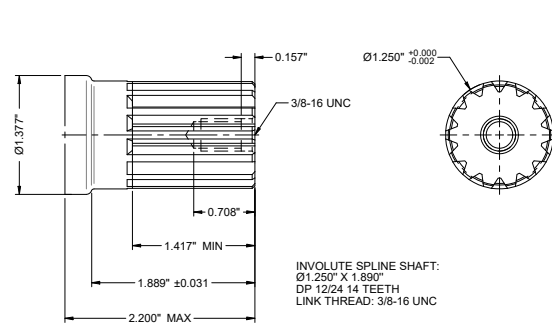

1" STRAIGHT KEY

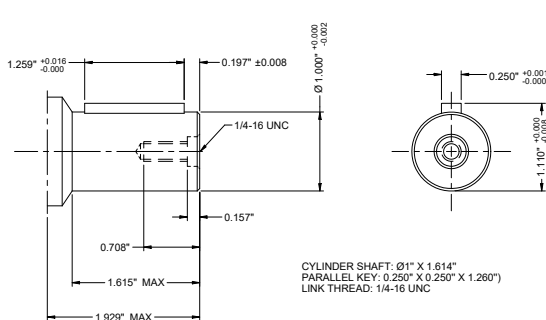

1"-6T SPLINED

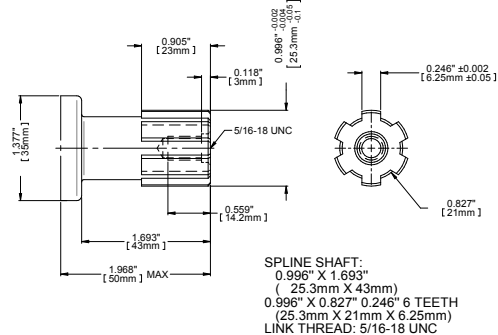

BMT IS A LARGE VOLUME DISC VALVE, HIGH PRESSURE MOTOR, WITH RADIAL BALL-BEARINGS DESIGN, AND CAN BEAR GREATER LOAD.

CHARACTERISTIC FEATURES

- THE MOTOR CAN BE USED IN HIGH PRESSURE AND HIGH TORQUE
- ADVANCED DESIGN IN DISC DISTRIBUTION FLOW, WHICH CAN PROVIDE IMPROVED PERFORMANCE AT LOW SPEED
- THE VALVE CAN AUTOMATICALLY COMPENSATE FOR THE WEAR, SO THE VOLUMETRIC EFFICIENCY IS HIGH
- DOUBLE TAPER ROLLER BEARINGS PERMIT HIGH RADIAL LOADS. THE MOTORS CAN BE USED ON HEAVIER VEHICLES IN TRACTION DRIVE APPLICATIONS

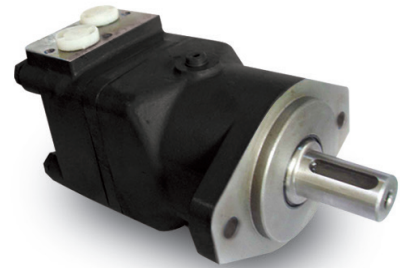

MAIN SPECIFICATIONS

DISPLACEMENT IN ³ (CM ³) / REV.		15.2 (250)	19.2 (315)	24.3 (400)	30.4 (500)	38.4 (630)	48.7 (800)
FLOW (GPM)	CONT.	33	33	33	33	33	33
	INT.	40	40	40	40	40	40
SPEED (RPM)	CONT.	495	380	302	237	196	154
	INT.	592	458	364	284	233	185
PRESSURE (PSI)	CONT.	2900	2900	2600	2320	2030	1812
	INT.	3480	3480	3045	2610	2320	1885
TORQUE (LB-IN)	CONT.	6435	8515	9691	11020	11665	12958
	INT.	7860	10214	11231	12471	13258	13453
LENGHT (IN)	L	8.37	8.58	8.86	9.17	9.65	10.22

- NOTES**
1. CONTINUOUS DATA: THE MAX. VALUE OF OPERATING MOTOR CONTINUOUSLY.
 2. INTERMITTENT DATA: THE MAX. VALUE OF OPERATING MOTOR IN 6 SECONDS PER MINUTE.
 3. A SIMULTANEOUS MAX. RPM AND MAX. PRESSURE IS NOT RECOMMENDED.
 4. THE CONVERSION FACTORS IS ON THE PAGE 4, CONSULT IT PLEASE.
 5. OPTIMUM OPERATING SITUATION SHOULD BE AT THE 1/3~2/3 OF THE CONTINUOUS OPERATING SITUATION.

MODEL CODES

FLANGE	SHAFT	15.2 (250)	19.2 (315)	24.3 (400)	30.4 (500)	38.4 (630)	48.7 (800)
SAE-C 4 BOLT	1 1/2" STRAIGHT	370-0141	370-0142	370-0143	370-0144	370-0145	370-0146

OTHER MOUNTINGS AND SHAFTS AVAILABLE

DIMENSIONS

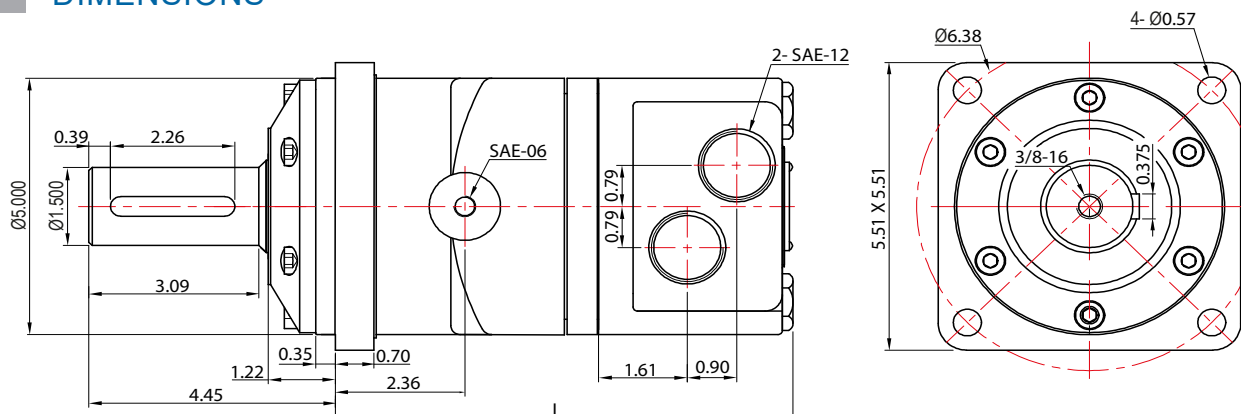

BM6 IS A LARGE VOLUME, DISC VALVE, HIGH PRESSURE MOTOR, WITH RADIAL BALL-BEARINGS DESIGN AND CAN BEAR GREATER LOAD, AND HAS HIGHER TORQUE CAPABILITIES THAN OUR BM5

CHARACTERISTIC FEATURES

- THE MOTOR CAN BE USED IN HIGH PRESSURE AND HIGH TORQUE
- ADVANCED DESIGN IN DISC DISTRIBUTION FLOW, WHICH CAN PROVIDE IMPROVED PERFORMANCE AT LOW SPEED
- THE VALVE CAN AUTOMATICALLY COMPENSATE FOR THE WEAR, SO THE VOLUMETRIC EFFICIENCY IS HIGH
- DOUBLE TAPER ROLLER BEARINGS PERMIT HIGH RADIAL LOADS. THE MOTORS CAN BE USED ON HEAVIER VEHICLES IN TRACTION DRIVE APPLICATIONS

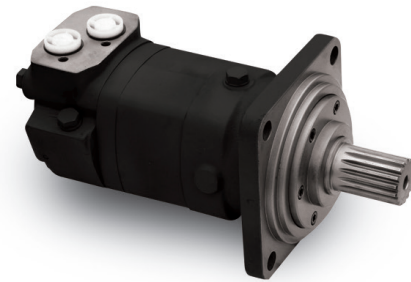

MAIN SPECIFICATIONS

DISPLACEMENT IN ³ (CM ³) / REV.		11.8 (195)	14.9 (245)	18.9 (310)	24.0 (395)	29.8 (490)	38.1 (625)	48.7 (800)	60.0 (985)
FLOW (GPM)	CONT.	40	40	40	40	40	40	40	40
	INT.	45	55	60	60	60	60	60	60
SPEED (RPM)	CONT.	775	615	485	383	307	241	184	153
	INT.	866	834	698	563	454	355	276	230
PRESSURE (PSI)	CONT.	2975	2975	2975	2975	2450	2030	1740	1740
	INT.	4500	4500	4500	4500	3990	2465	2030	2030
TORQUE (LB-IN)	CONT.	5083	6497	8212	10051	10723	11731	12483	13852
	INT.	7602	10440	11934	14453	16619	12155	14551	16540
LENGHT (IN)	L3	10.15	10.35	10.63	11.02	11.42	12.00	12.83	13.58

- NOTES**
1. CONTINUOUS DATA: THE MAX. VALUE OF OPERATING MOTOR CONTINUOUSLY.
 2. INTERMITTENT DATA: THE MAX. VALUE OF OPERATING MOTOR IN 6 SECONDS PER MINUTE.
 3. A SIMULTANEOUS MAX. RPM AND MAX. PRESSURE IS NOT RECOMMENDED.
 4. THE CONVERSION FACTORS IS ON THE PAGE 4, CONSULT IT PLEASE.
 5. OPTIMUM OPERATING SITUATION SHOULD BE AT THE 1/3-2/3 OF THE CONTINUOUS OPERATING SITUATION.

MODEL CODES

FLANGE	SHAFT	11.8 (195)	14.9 (245)	18.9 (310)	24.00 (395)	29.8 (490)	38.1 (625)	48.7 (800)	60.0 (985)
SAE-C 4 BOLT	1 1/2" STRAIGHT	361-0181	361-0182	361-0183	361-0184	361-0185	361-0186	361-0188	361-0187

OTHER MOUNTINGS AND SHAFTS AVAILABLE

DIMENSIONS

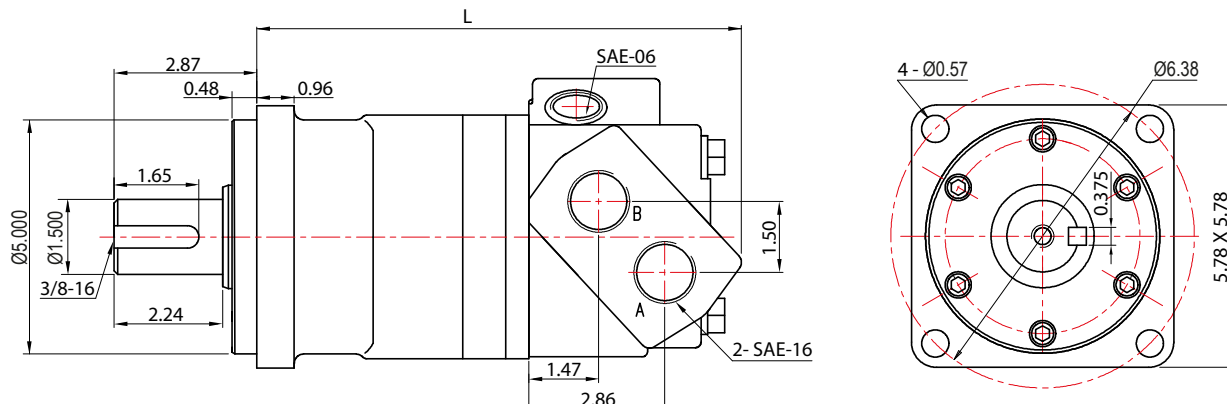

BMV IS A DISC VALVE, HIGH PRESSURE MOTOR, WITH RADIAL BALL-BEARINGS DESIGN AND EFFICIENT PERFORMANCE WHICH CAN BEAR GREATER LOAD THAN BMT. ITS FIGURATION IS BIGGER THAN **BMT**.

CHARACTERISTIC FEATURES

- THE MOTOR CAN BE USED IN HIGH PRESSURE AND HIGH TORQUE
- ADVANCED DESIGN IN DISC DISTRIBUTION FLOW, WHICH CAN PROVIDE IMPROVED PERFORMANCE AT LOW SPEED
- THE VALVE CAN AUTOMATICALLY COMPENSATE FOR THE WEAR, SO THE VOLUMETRIC EFFICIENCY IS HIGH
- DOUBLE TAPER ROLLER BEARINGS PERMIT HIGH RADIAL LOADS. THE MOTORS CAN BE USED ON HEAVIER VEHICLES IN TRACTION DRIVE APPLICATIONS



MAIN SPECIFICATIONS

DISPLACEMENT IN ³ (CM ³) / REV.		19.2 (315)	24.3 (400)	30.4 (500)	38.4 (630)	48.7 (800)	60.9 (1000)
FLOW (GPM)	CONT.	42	53	53	53	53	53
	INT.	53	63	63	63	63	63
SPEED (RPM)	CONT.	510	500	400	320	250	200
	INT.	630	600	480	380	300	240
PRESSURE (PSI)	CONT.	3045	3045	3045	3045	3045	3045
	INT.	3625	3625	3625	3625	3625	3625
TORQUE (LB-IN)	CONT.	7213	10502	13039	14869	15824	17813
	INT.	9892	12659	15611	17371	17689	20155
LENGHT (IN)	L	8.38	8.66	8.98	9.44	10.02	10.65

- NOTES**
1. CONTINUOUS DATA: THE MAX. VALUE OF OPERATING MOTOR CONTINUOUSLY.
 2. INTERMITTENT DATA: THE MAX. VALUE OF OPERATING MOTOR IN 6 SECONDS PER MINUTE.
 3. A SIMULTANEOUS MAX. RPM AND MAX. PRESSURE IS NOT RECOMMENDED.
 4. THE CONVERSION FACTORS IS ON THE PAGE 4, CONSULT IT PLEASE.
 5. OPTIMUM OPERATING SITUATION SHOULD BE AT THE 1/3-2/3 OF THE CONTINUOUS OPERATING SITUATION.

MODEL CODES

FLANGE	SHAFT	19.2 (315)	24.3 (400)	30.4 (500)	38.4 (630)	48.7 (800)	60.9 (1000)
SAE-C 4 BOLT	2 1/4" STRAIGHT	381-0021	381-0022	381-0023	381-0024	381-0025	381-0026

OTHER MOUNTINGS AND SHAFTS AVAILABLE

DIMENSIONS

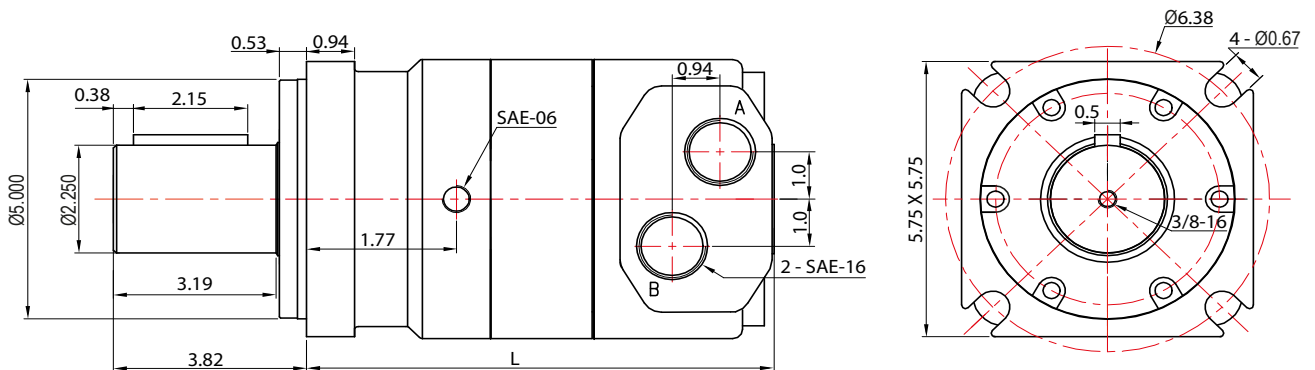

BM2B BRAKE MOTOR

BM2B BRAKE MOTOR IS DESIGNED WITH BRAKE DEVICE, SHUTTLE VALVE, INTERNAL CONTROL OIL LOOP. COMPACT DESIGN FOR SMALL VOLUME AND EASY INSTALLATION.

DISPLACEMENT IN ³ (CM ³) / REV.	4.8 (80)	6.1 (100)	7.6 (125)	9.7 (160)	12.2 (200)	15.2 (250)	19.2 (315)
RELEASE PRESSURE (PSI)	188-246	188-246	188-246	320-375	320-375	320-375	320-375
BRAKE TORQUE (Nm) (LB-IN)	<=300 <=2655	<=300 <=2655	<=300 <=2655	<=500 <=4425	<=500 <=4425	<=500 <=4425	<=500 <=4425
MAX PSI	2030	2030	2030	2030	2030	1595	1305
MAX GPM	13	13	13	13	13	13	13



BM6B BRAKE MOTOR

BM6B MOTOR IS A BM6 WITH MULTI-DISC BRAKE WHICH RELEASES USING HYDRAULIC PRESSURE. THE MOTOR HAS THE SAME WORK PERFORMANCE AS A REGULAR BM6 WHEN THE BRAKE IS RELEASED.

DISPLACEMENT IN ³ (CM ³) / REV.	11.8 (195)	14.9 (245)	18.9 (310)	24.0 (395)	29.8 (490)	38.1 (625)
RELEASE PRESSURE (PSI)	362	362	362	362	362	362
BRAKE TORQUE (Nm) (LB-IN)	<=800 <=1080	<=800 <=1080	<=800 <=1080	<=800 <=1080	<=800 <=1080	<=800 <=1080
MAX PSI	2975	2975	2975	2975	2465	2465
MAX GPM	40	40	40	40	40	40

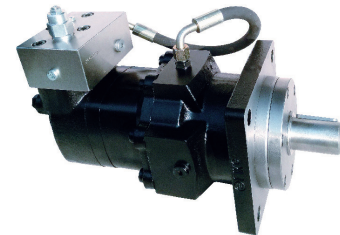

HYDRAULIC BRAKES TO INSTALL ON MOTORS

ZD80 AND ZD100 SERIES HYDRAULIC BRAKES ARE MULTI-DISC BRAKE DESIGN. THEY ARE WIDELY APPLIED IN HEAVY LOAD MACHINES SUCH AS; CRANES, AGRICULTURAL MACHINES, ENVIRONMENTAL SANITATION MACHINES, ETC.

- COMPACT DESIGN
- CAN BE INDEPENDENTLY USED WITHOUT MOTORS
- EXCELLENT PERFORMANCE
- EASY TO INSTALL

MAIN SPECIFICATION

MODELS	ZD80	ZD100
MIN STATIC TORQUE (LB-IN)	3982	4865
MIN OPENING PRESSURE (PSI)	362	
MAX OPENING PRESSURE (PSI)	4350	
MIN OIL QUANTITY FOR BRAKE RELEASING (CC)	7-8	
OIL VOLUME (CC)	50-120	
MAX PRESSURE IN DRAIN SPACE (PSI)	7	

MODEL CODE	FEMALE	MALE	MOUNTING FLANGE
ZD80-A014	1"-6T SPLINE	1"-6T SPLINE	SAE-A 2/4 BOLTS
ZD80-A024		1" KEY	



CROSSOVER RELIEF VALVES

- MADE TO ABSORB PEAK OF PRESSURE
- COMPACT DESIGN
- FITS MANY MANUFACTURERS

MODEL CODE	FITS ON MOTORS	PSI RANGE	PORT SIZE
469-8210	BMM	500-2000	SAE-06
460-2100	BM1/BM2	725-1450	SAE-10
460-2210	BM1/BM2	1000-3000	
465-1210	BM5	1000-3000	

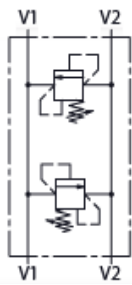

INTEGRATED COUNTERBALANCE VALVES

- MADE TO SMOOTHLY BRAKE ROTATION
- FITS ON BM1 & BM2 MOTORS- INTEGRATE A
- SHUTTLE TO SEND A SIGNAL/OIL

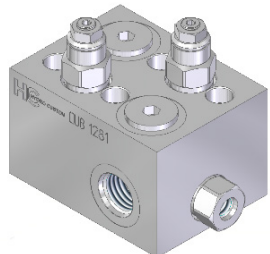
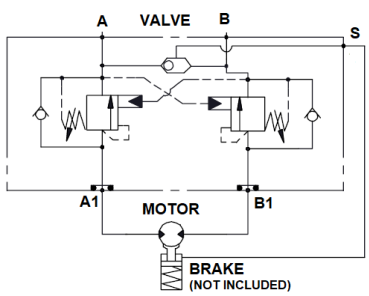

MODEL CODE ZUB 1281

STEERING COLUMNS

- FITS ON MOST COMMON DANFOSS & CHARLYNN UNITS

MODEL CODE	LENGTH (IN)
651-1579-S	6.0
650-1500-S	8.0
651-1504-S	16.0

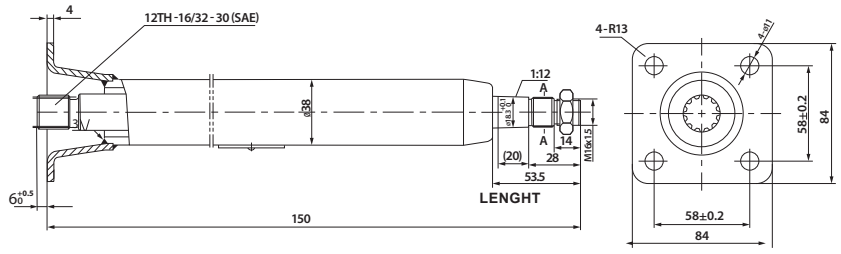

1.5ME SERIE

- BI-DIRECTIONAL
- SAE-AA 2 BOLT MOUNTING FLANGE
- 1/2 PARALLEL SHAFT
- SAE 04 DRAIN PORT
- * **NEW HIGH PRESSURE SHAFT SEAL AVAILABLE**
CAN GO UP TO 450 PSI COMPARE TO 43 PSI WITHOUT



MODEL CODE	DISPLACEMENT IN ³ (CM ³) / REV.	MAX PSI	RPM MIN	RPM MAX	PORT SIZE IN & OUT
610910328	0.17 (2.8)	3625	700	4500	SAE-08
610911088	0.21 (3.5)	3625		4500	
610910348	0.25 (4.1)	3625		4000	
610911098	0.32 (5.2)	3335		4000	
610910368	0.38 (6.2)	3335	600	3600	SAE-10
610911108	0.46 (7.6)	2900		3300	
610910388	0.57 (9.3)	2610		3000	
610910398	0.67 (11)	2465		3000	

2ME SERIE

- BI-DIRECTIONAL
- SAE-A 2 BOLT MOUNTING FLANGE
- 5/8" PARALLEL SHAFT
- SAE 04 DRAIN PORT
- * **NEW HIGH PRESSURE SHAFT SEAL AVAILABLE**
CAN GO UP TO 450 PSI COMPARE TO 43 PSI WITHOUT



MODEL CODE	DISPLACEMENT IN ³ (CM ³) / REV.	MAX PSI	RPM MIN	RPM MAX	PORT SIZE IN & OUT
612095948	0.40 (6.5)	3600	600	4000	SAE-10
612081668	0.50 (8.3)		500	3600	
612083618	0.68 (11.3)			3500	
612084388	0.84 (13.8)			3400	
612084398	1.01 (16)	3140	450	3200	SAE-12
612084408	1.15 (19)			3000	
612084418	1.37 (22.5)			2900	
612084428	1.58 (26)			2600	

- ALSO AVAILABLE**
- OTHER SHAFT DIMENSIONS
 - OUTRIGGER BEARING TO ACCEPT SIDE LOAD
 - REAR PORT COVER
 - INTERNAL DRAIN

2MGE CAST IRON SERIE

- BI-DIRECTIONAL
- SAE-A 2 BOLT MOUNTING FLANGE
- 5/8" PARALLEL SHAFT
- SAE 04 DRAIN PORT
- * **NEW HIGH PRESSURE SHAFT SEAL AVAILABLE**
CAN GO UP TO 450 PSI COMPARE TO 43 PSI WITHOUT



MODEL CODE	DISPLACEMENT IN ³ (CM ³) / REV.	MAX PSI	RPM MIN	RPM MAX	PORT SIZE IN & OUT
614670872	1.01 (16)	3600	450	3200	SAE-10
614670882	1.18 (19)	3140	450	3200	SAE-12
614670892	1.37 (22.5)	2900	450	3000	SAE-12
614670902	1.58 (26)	2600	450	2850	SAE-12

3ME SERIE

- BI-DIRECTIONAL
- SAE-B 2 BOLT MOUNTING FLANGE
- 7/8" PARALLEL SHAFT
- 3/8" BSP DRAIN PORT
- * **NEW HIGH PRESSURE SHAFT SEAL AVAILABLE :**
CAN GO UP TO 450 PSI COMPARE TO 43 PSI WITHOUT



MODEL CODE	DISPLACEMENT IN ³ (CM ³) / REV.	MAX PSI	RPM MIN	RPM MAX	PORT INLET	PORT OUTLET
612978738	1.65 (27)	3600	600	3000	SAE-16	SAE-12
612978748	2.04 (38)		500			
612978768	2.86 (46)	3500	400	2750	SAE-20	SAE-16
612978778	3.30 (55)	3190		2500		

ALSO AVAILABLE

- OTHER SHAFT DIMENSIONS
- OUTRIGGER BEARING TO ACCEPT SIDE LOAD
- REAR PORT COVER
- INTERNAL DRAIN

- AVAILABLE WITH ISO, SAE AND DIN STANDARD MOUNTING
- HIGH SPEED AND HIGH EFFICIENCY MOTORS
- SMOOTH OPERATION OVER THE ENTIRE SPEED RANGE
- LONG LIFE WITH HIGH PERFORMANCES

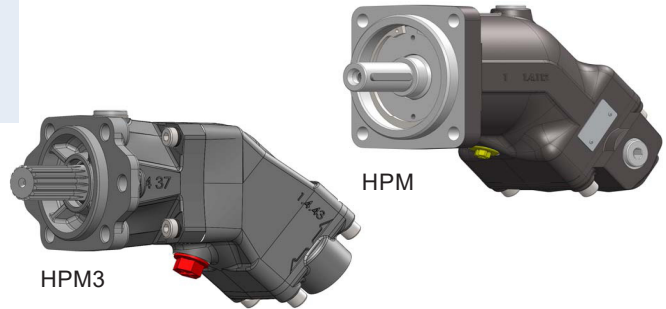

HPM3 SERIE

MODEL CODE	DISPLACEMENT IN ³ (CM ³) / REV.	PRESSURE (PSI)	RPM	PORT SIZE	MOUNTING FLANGE	SHAFT
213 074 05040	2.44 (40)	5075 CONT. 5800 INT.	100 MIN 1900 CONT. 2500 INT.	SAE-16	SAE-B 2/4B	7/8-13T SPLINE
214 080 05040					SAE-C 4B	1 1/4-14T SPLINE
214 091 05040					SAE-C 4B	1 1/4 STRAIGHT
214 080 05047	2.87 (47)	4900	100 MIN 1900 CONT. 2500 INT.	SAE-16	SAE-C 4B	1 1/4-14T SPLINE
214 090 05047					SAE-C 4B	1 1/4 STRAIGHT
214 080 05055	3.36 (55)	4060	100 MIN 1900 CONT. 2500 INT.	SAE-16	SAE-C 4B	1 1/4-14T SPLINE
214 090 05055					SAE-C 4B	1 1/4 STRAIGHT
214 080 05064	3.90 (64)	3625	100 MIN 1900 CONT. 2500 INT.	SAE-16	SAE-C 4B	1 1/4-14T SPLINE
214 091 05064					SAE-C 4B	1 1/4 STRAIGHT

HPM SERIE

MODEL CODE	DISPLACEMENT IN ³ (CM ³) / REV.	PRESSURE (PSI)	RPM	PORT SIZE	MOUNTING FLANGE	SHAFT
221 074 06012	1.04 (12)	5075 CONT. 5800 INT.	100 MIN 6300 CONT. 6800 INT.	SAE-12	SAE-B 2B	7/8-13T SPLINE
221 091 06012						1" STRAIGHT
221 074 06017	1.04 (17)	5075 CONT. 5800 INT.	100 MIN 6300 CONT. 6800 INT.	SAE-12	SAE-B 2B	7/8-13T SPLINE
221 091 06017						1" STRAIGHT
221 074 05025	1.53 (25)	5075 CONT. 5800 INT.	100 MIN 6300 CONT. 6800 INT.	SAE-12	SAE-B 2B	7/8-13T SPLINE
221 091 05025						1" STRAIGHT
221 077 05025						1"-15T SPLINE
221 074 05034	2.07 (34)	5075 CONT. 5800 INT.	100 MIN 6300 CONT. 6800 INT.	SAE-12	SAE-B 2B	7/8-13T SPLINE
221 091 05034						1" STRAIGHT
221 077 05034						1"-15T SPLINE
224 094 05040	2.44 (40)	5075 CONT. 5800 INT.	100 MIN 5000 CONT. 5500 INT.	SAE-16	SAE-C 4B	1 1/4 STRAIGHT
224 094 05047	2.87 (47)					
224 094 05055	3.36 (55)					
224 094 05064	3.90 (64)					
224 094 21080	4.88 (80)	5075 CONT. 5800 INT.	100 MIN 4000 CONT. 4500 INT.	CODE 62 FLANGE 3/4	SAE-C 4B	1 1/4 STRAIGHT
224 094 21091	5.55 (91)					
224 094 21108	6.59 (108)					

ANTI-CAVITATION VALVE

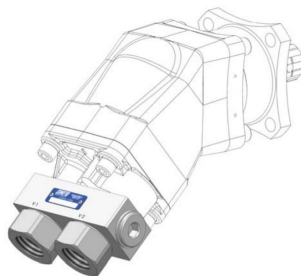
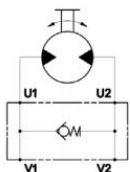

SPEED SENSOR



TMF 900

FIXED DISPLACEMENT AXIAL PISTON MOTORS



FEATURES:

- HIGH PRESSURE
- HIGH ROTATION SPEED
- EXCELLENT VOLUMETRIC AND MECHANICAL EFFICIENCY
- COMPACT DESIGN

DISPLACEMENT IN ³ (CM ³) / REV.	MAX			WEIGHT KG (LB)
	PSI (RATED)	PSI PEAK	RPM	
4.4 (72)	5800	6525	4100	28 (62)
5.5 (90)			4000	
6.7 (110)			3800	
				34 (75)

TMV 550

TWO SPEED AXIAL PISTON MOTORS



FEATURES:

- EXCELLENT WEIGHT/POWER RATIO
- HIGH ROTATION SPEED
- EXCELLENT VOLUMETRIC AND MECHANICAL EFFICIENCY
- COMPACT DESIGN

DISPLACEMENT IN ³ (CM ³) / REV.	MAX			WEIGHT KG (LB)
	PSI (RATED)	PSI PEAK	RPM	
2.7 (46)	4350	5800	4000	20 (44)
3.1 (50)				
3.9 (64)				

TMV 650

TWO SPEED AXIAL PISTON PLUG-IN MOTORS



FEATURES:

- SWASHPLATE DESIGN FOR HYDROSTATIC TRANSMISSIONS
- PLUG-IN MOUNTING
- HEAVY DUTY BEARINGS FOR LONG SERVICE LIFE
- HIGH PERMISSIBLE OUTPUT SPEED

DISPLACEMENT IN ³ (CM ³) / REV.	MAX			WEIGHT KG (LB)
	PSI (RATED)	PSI PEAK	RPM	
1.5 (25)	4350	5075	3500	15,6 (34)
1.8 (30)				
2.1 (35)				
2.3 (38)				
2.7 (45)				

TMF 600

FIXED DISPLACEMENT AXIAL PISTON MOTORS

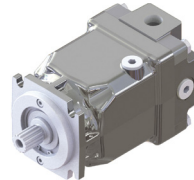

FEATURES:

- HIGH STARTING TORQUE
- SMOOTH OPERATION
- LONG SERVICE LIFE
- HIGH POWER DENSITY
- BUILT-IN VALVES AVAILABLE
- SPEED SENSOR AVAILABLE

DISPLACEMENT IN ³ (CM ³) / REV.	MAX			WEIGHT KG (LB)
	PSI (RATED)	PSI PEAK	RPM	
1.3 (22)	5075	6090	4200	11,3 (25)
1.7 (28)			4000	
2.1 (35)		5945	3600	17,8 (39)
2.4 (40)				
2.8 (46)				
3.1 (50)				
3.8 (63)		6090	3500	32,5 (72)
4.3 (71)				
4.6 (75)				
5.6 (92)				
100 (6.1)	5945			

Our power units follow the same vigorous production and assembly processes as the rest of our products. The Hydro Custom power units are used in various applications :

- Car lift
- Snow plow
- Dock leveler
- Lift table
- Scissor lift
- Tail gate
- Fork lift
- Tipper trailer
- Dump trailer
- Garbage truck
- RV
- Wheel chair and medical

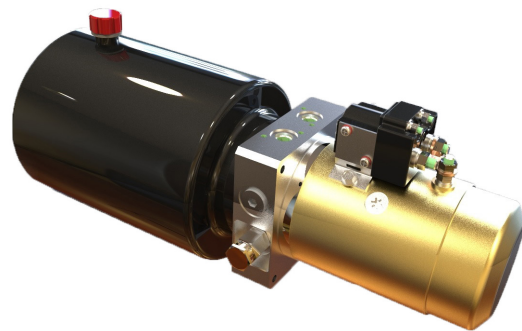
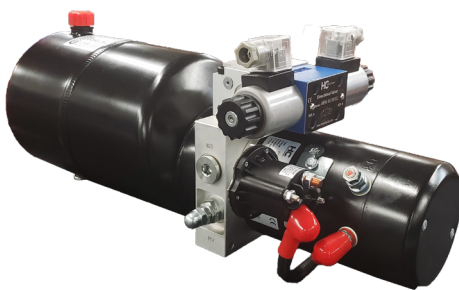

FEATURES AND BENEFITS

- Choice of configurations of multiple components such as pumps, valves, motors and tanks
- Experienced advisors in hydraulic circuit conception that will help you with the design of powers units according to your needs and requirements
- Power units can be fitted with blocks manifold designed to your specifications and manufactured in our workshops
- Mounting and testing of power units in a clean environment and without contamination, according to procedures established by highly qualified technicians
- Manufacturing customized solutions or series are possible taking into consideration the time of execution, the amount and the budgetary
- Price constraints
- 3D drawings, hydraulic and electrical plans and reports of tests (flow, pressure, speed, etc.) upon request
- Variety of standard power units distributed in our three warehouses across North America
- Several points of service in North America with hydraulic spare parts
- Well studied Quality/Price Ratio in order to provide you with the best possible offer
- Tank can be used horizontally or vertically

Whatever your requirements, our experienced team will be able to design the unique hydraulic solution that meets your individual specifications. Project appraisal, inventory request and orders are accessible to affiliated distributors.

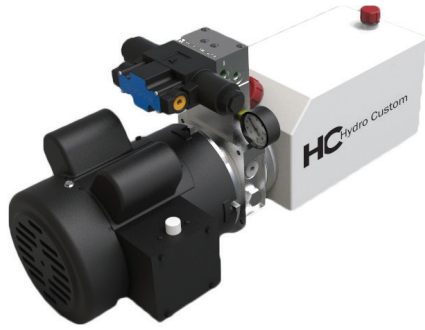
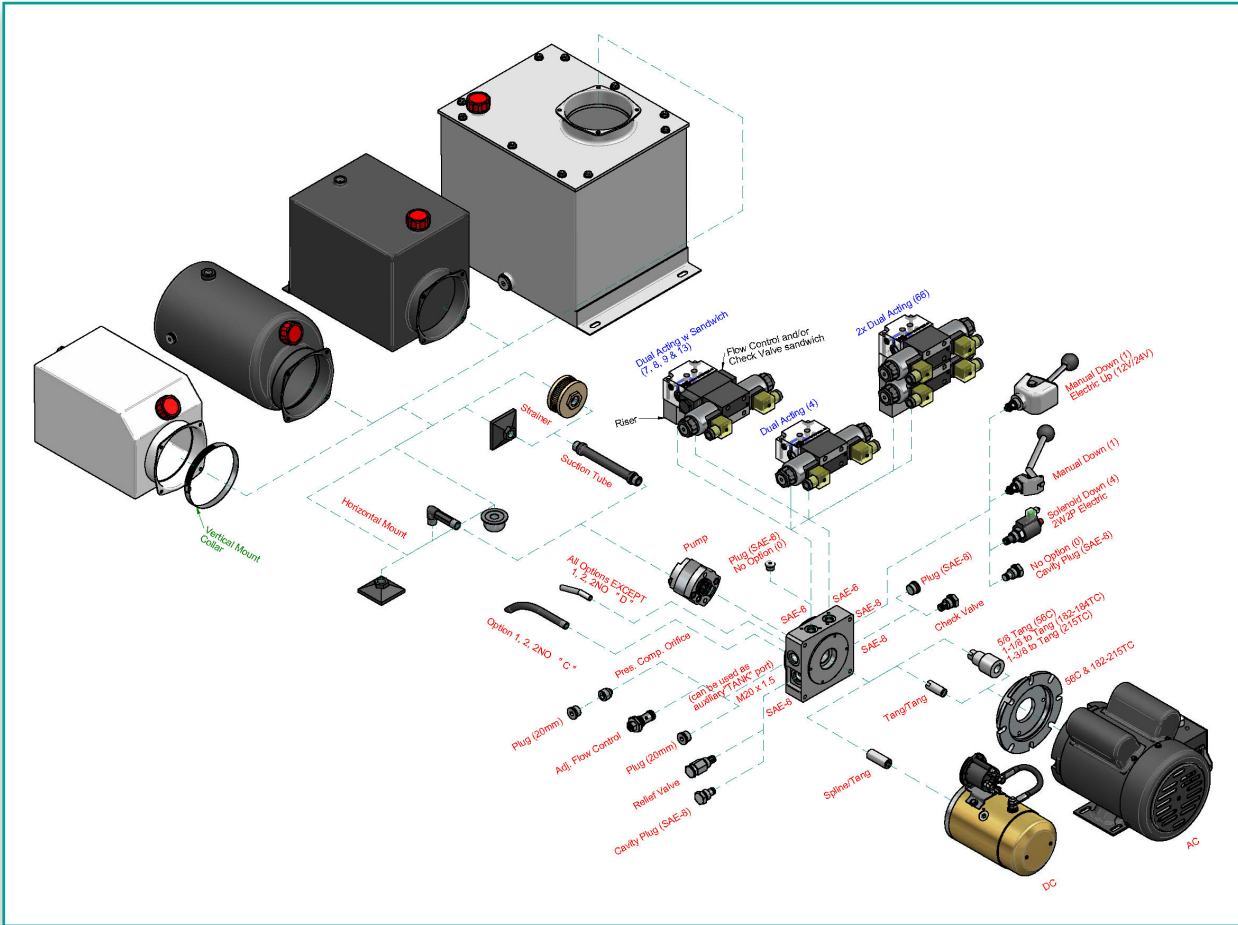

MODEL CODE

EXAMPLE

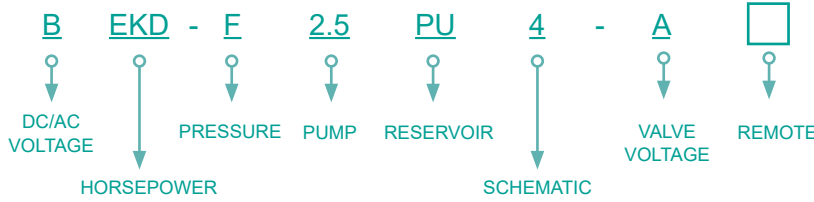

VOLTAGE & POWER

DC MOTORS 2500 RPM

CODE	VOLTAGE & HORSEPOWER
1W2W	12V, 2 HP
2A2W	24V, 2.5 HP

AC MOTORS 1800 RPM

CODE	VOLTAGE
B	110/220V, 1 PH. (UP TO 2HP)
C	575V, 3 PH.
D	220V, 1PH. (3HP AND MORE)
E	208-230/460V, 3 PH.

CODE	HORSEPOWER
CKE	1/2 HP
DKE	3/4 HP
EKE	1 HP
EKD	1 HP (TANG SHAFT)
EKDB	1 HP + BUTTON & CABLE*
EKDT	1 HP + TOGGLE & CABLE*
FKE	1 1/2 HP
GKE	2 HP
GKD	2 HP (TANG SHAFT)
HKH	3 HP
JKJ	5 HP
KKK	7.5 HP

*AVAILABLE FOR 110/220V MOTORS ONLY

PRESSURE

CODE	PRESSURE
X	NO RELIEF
D	580 - 2300 PSI
F	1150 - 3000 PSI
H	1750 - 3600 PSI

PUMPS

CODE	MAX PSI *	MAX RPM	FLOW GPM	
			AC UNIT	DC UNIT
0.8	3300	6000	0.34	SEE CHARTS
1.2	3300	6000	0.51	
1.6	3300	6000	0.69	
2.1	3300	6000	0.90	
2.5	3300	6000	1.05	
3.2	3000	5000	1.36	
4.2	3000	4000	1.80	
6.0	2750	3000	2.50	
8.0	2320	2100	3.40	
8H	3700	5000	3.43	

*PLEASE REFER TO THE PRESSURE LIMITATION CHART

PRESSURE LIMITATION (PSI) MOTOR & PUMP COMBINATION

HP	PUMP CODE									
	0.8	1.2	1.6	2.1	2.5	3.2	4.2	6.0	8.0	8H
1/2	2140	1400	1050	800	680	530	400	280	210	210
3/4	3200	2140	1580	1200	1020	800	600	420	320	320
1	3300	2850	2100	1600	1360	1060	800	560	430	430
1 1/2	3300	3300	3167	2430	2040	1600	1200	850	640	640
2	3300	3300	3300	3230	2720	2120	1600	1140	850	850
3	3300	3300	3300	3300	3300	3000	2430	1700	1270	1270
5	3300	3300	3300	3300	3300	3000	3000	2350	1700	2100
7 1/2	3300	3300	3300	3300	3300	3000	3000	2350	1700	2500

12VDC UNITS GPM FLOW CHART

PSI	PUMP (CC)						
	0.8	1.2	1.6	2.1	2.5	3.2	4.2
0	0,99	1,50	1,53	2,51	2,71	3,24	4,25
500	0,87	1,33	1,35	1,88	2,25	2,71	2,91
1000	0,85	1,18	1,12	1,65	1,98	2,31	2,14
1500	0,77	1,12	1,06	1,48	1,72	1,78	1,59
2000	0,73	1,04	0,95	1,35	1,53	1,65	1,19
2500	0,69	0,95	0,9	1,12	1,39	1,45	0,9
3000	0,63	0,71	0,79	1,03	1,22	1,32	0,85

WARNING! MORE THAN 250 AMPERES

24VDC UNITS GPM FLOW CHART

PSI	PUMP (CC)						
	0.8	1.2	1.6	2.1	2.5	3.2	4.2
0	1,12	1,74	2,05	2,38	2,77	3,31	3,43
500	0,90	1,34	1,62	1,78	2,11	2,54	2,64
1000	0,79	1,19	1,41	1,62	1,72	2,01	2,18
1500	0,73	1,04	1,21	1,37	1,40	1,45	1,78
2000	0,66	0,95	1,12	1,19	1,22	1,32	1,59
2500	0,63	0,89	0,99	1,06	1,16	1,21	1,39
3000	0,59	0,79	0,94	0,92	1,11	1,20	1,32

DIMENSIONS

DC MOTORS

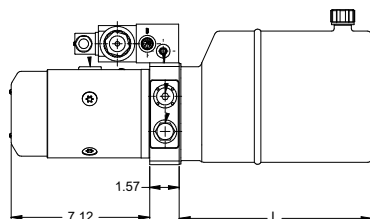

AC MOTORS

HP	DIM "C" (IN)
1/2	12.1
3/4	
1	
1 1/2	
2	18.5
3	
5	
7.5	20.9

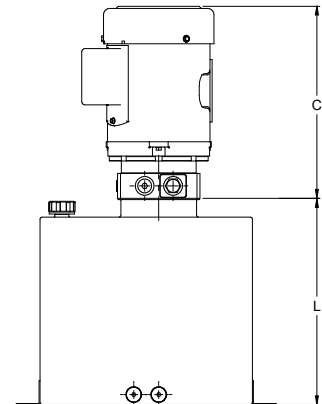

RESERVOIRS

BREATHER WITH DIPSTICK INCLUDED

PLASTIC HORIZONTAL

CODE	GALLONS	USABLE	DIM "L" (IN)
PA	1.0	0.7	7.9
PB	1.3	1.2	11.4
PL	1.6	1.4	13.2
PC	2.1	2.1	17.3
PD	2.6	2.5	20.9
PE	3.2	2.6	21.6
PG	3.7	2.9	23.4
PP	4.2	3.4	27.6
PQ	5.5	5.2	41.3

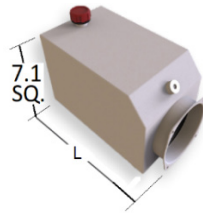

PLASTIC VERTICAL

CODE	GALLONS	USABLE	DIM "L" (IN)
QA	1.0	0.7	7.9
QB	1.3	1.2	11.4
QL	1.6	1.4	13.2
QC	2.1	2.1	17.3
QD	2.6	2.5	20.9
QE	3.2	2.6	21.6
QG	3.7	2.9	23.4
QP	4.2	3.4	27.6
QQ	5.5	5.2	41.3

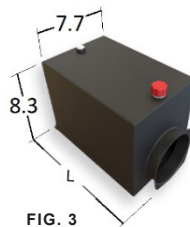
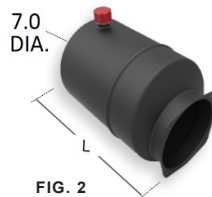
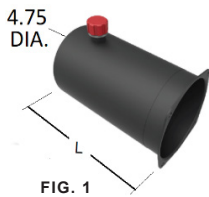
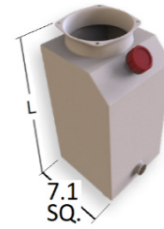

STEEL HORIZONTAL

CODE	GALLONS	USABLE	DIM "L" (IN)	FIG.
RY	0.4	0.26	6.3	1
RZ	0.5	0.4	8.5	
RA	1.0	0.8	9.0	2
RB	1.3	1.1	10.6	
RL	1.6	1.4	11.4	
RC	2.1	1.9	14.6	
RD	2.6	2.4	17.3	3
RE	3.2	3.0	21.3	
SD	2.6	2.2	10.2	
SE	3.2	2.6	11.8	
SF	4.0	3.6	16.1	
SH	5.3	4.7	21.0	
SJ	6.6	6.2	27.8	

STEEL VERTICAL

CODE	GALLONS	USABLE	DIMS (IN)			FIG.		
			H	W	L			
TA	1.0	0.7	9.0	4	4	4		
TB	1.3	0.9	10.6					
TL	1.6	1.2	11.4					
TC	2.1	1.7	14.6					
TD	2.6	2.2	17.3	5	5	5		
TE	3.2	2.8	21.3					
UP	4.2	3.9	23.2					
UQ	5.5	5.1	29.2	6	6	6		
U2	6.5	6.0	11.0				13.4	13.0
U3	9.2	8.5	13.4				14.2	13.0
U4	10.6	10.0	11.0				13.4	19.0
U6	15.9	15.0	13.8	17.7	17.3			

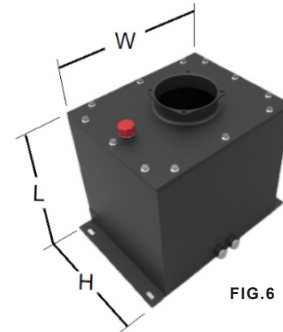

SCHEMATICS

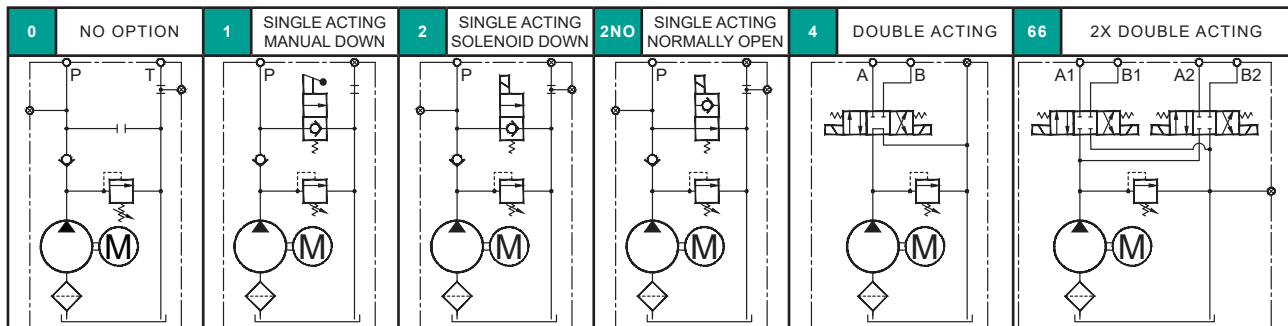

VALVES VOLTAGE

CODE	DESCRIPTION
OMIT	NO VOLTAGE
A	12VDC
B	24VDC
C	110VAC

REMOTE CONTROLS

CODE	DESCRIPTION
OMIT	NO REMOTE
R*	REMOTE CONTROL (10 FOOT CABLE)

* DC MOTORS ONLY



OTHER SCHEMATICS

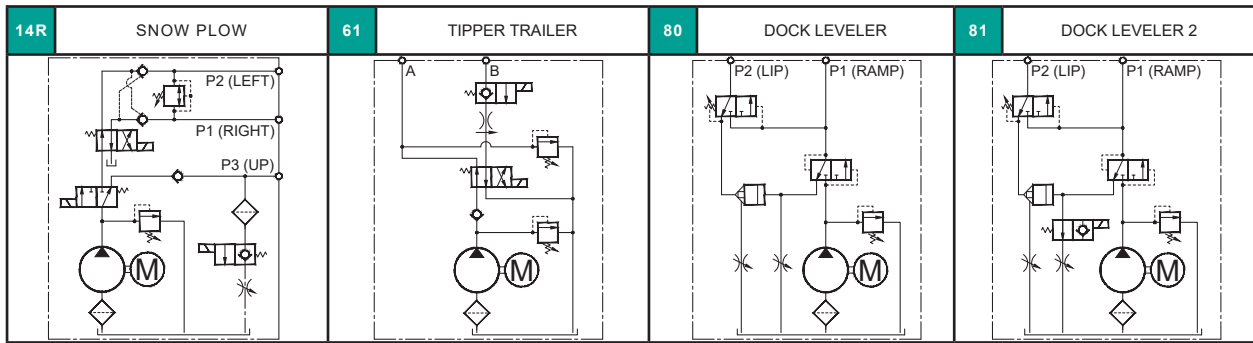

PICKUP SNOW PLOWS

SPECIAL DESIGN DC DRIVEN POWER PACK WITH REMOTE

MODEL CODE: 1W2W-F2.5RY14-AR

- CUSHION VALVE TO ABSORB SHOCKS ON LEFT-RIGHT MOVEMENT
- MADE FOR 3 SINGLE ACTING CYLINDERS
- LEFT/RIGHT LIFT AND FLOAT

REMOTE SPECIFICATIONS

- 2 AXIS JOYSTICK (LEFT, RIGHT, UP & DOWN)
- ROCKER SWITCH WITH LIGHT TO ACTIVATE FLOAT POSITION
- 10 FT. CABLE



TIPPER TRAILERS

- DC DRIVEN HYDRAULIC POWER PACK FOR DUMPERS WITH REMOTE



DOCK LEVELERS

- AC DRIVEN POWER PACK USED ON ALL MAJOR LOADING DOCKS
- SEQUENTIAL LIP LIFT ACTION



CAR LIFTS

- AC DRIVEN POWER PACK USED ON CAR/TRUCK LIFTS FOR MAINTENANCE OR STORING APPLICATIONS



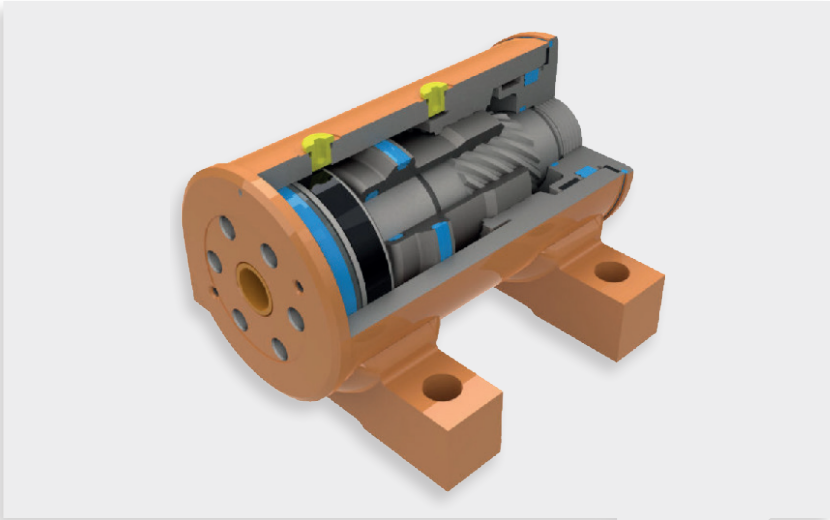

Powerful
High torque
High bearing



Drift free positioning
Zero internal leakage
Smooth operation
No external brake required



Backdrives in overload conditions
Hydraulic fuse
Prevents mechanical damage



Ultra-Compact
High power density
Fits in tight spaces



Streamline design
Eliminates linkages and bearings
Reduced bill of materials



Durable
Suitable for harsh environments
Moving parts enclosed

TEFC MOTORS

- CHOICE OF 1/3 TO 20HP
- 1800 RPM (3600 RPM AVAILABLE)
- SINGLE AND THREE PHASE
- NEMA FRAME FROM 56 TO 215TC
- IP44 CLASS, 1.15 FS



HP	MODEL CODE			FRAME
	115/230V SINGLE PHASE	575V 3 PHASE	208-230/460V 3 PHASE	
1/3	F56C1/3S4C	F56C1/3M4D	F56C1/3M4A	56C
1/2	F56C1/2S4C	F56C1/2M4D	F56C1/2M4A	
3/4	F56C3/42S4C	F56C3/4M4D	F56C3/4M4A	
1	F56C1S4	F56C1M4D	F56C1M4A	
1.5	F56C1.5S4C	F56C1.5M4D	F56C1.5M4A	
2	F56C2S4C	F56C2M4D	F56C2M4A	
3	-	F182TC3M4D	F182TC3M4A	182TC
5	-	F184TC5M4D	F184TC5M4A	184TC
7.5	-	F215TC7.5M4D	F215TC7.5M4A	213TC
10	-	F215TC10M4D	F215TC10M4A	215TC
15	-	F215TC15M4D	F215TC15M4A	

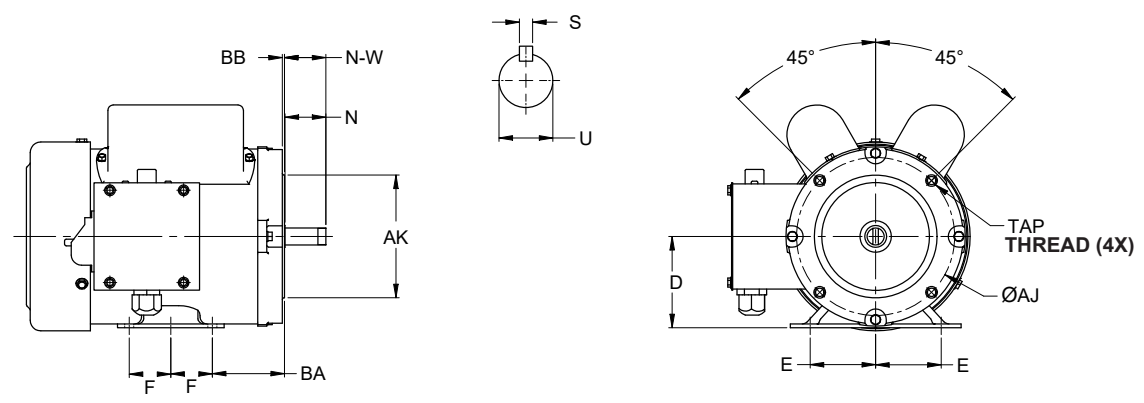

FRAME SIZE	DIMENSIONS (IN)											THREAD
	D	E	F	N	U	S	N-W	AJ	AK	BA	BB	
56C	3.50	2.44	1.50	1.93	5/8	3/16	1.88	5.88	4.50	2.75	0.16	3/8-16 UNC
143TC	3.50	2.75	2.00	2.31	7/8	3/16	2.25	5.88	4.50	2.25		
145TC			2.50									
182TC 184TC	4.50	3.75	2.25	2.88	1 1/8	1/4	2.75	7.25	8.50	2.75	0.25	1/2-12 UNC
213TC	5.25	4.25	2.75	3.38	1 3/8	5/16	3.13	7.25	8.50	3.50		
215TC			3.50									

- VERY ECONOMICAL & COMPACT DESIGN
- DIRECT MOUNT MOTOR CAN BE ORDERED SEPARATELY

MODEL CODE

EXAMPLE: DM56CS4C - 4PS2.8

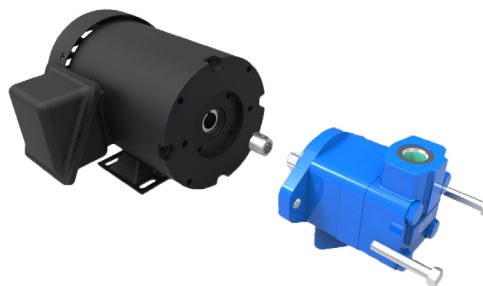
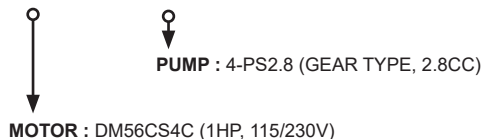

MOTORS - TEFC - 1800 RPM

HP	MODEL CODE			FRAME	PUMP SIDE FLANGE & SHAFT
	115/230V SINGLE PHASE	575V THREE PHASES	208-230/460V THREE PHASES		
1/2	DM56C1/2S4CF	-	-	56C	SAE-A 2B FLANGE & SAE AA-4B FLANGE
3/4	DM56C3/4S4CF	-	-		
1	DM56C1S4CF	-	-		
1 1/2	DM56C1.5S4CF	-	-		
2	DM56C2S4CF	-	-		
3	DM56C3S4CF	-	-		
	-	DM215TC3M4DF	DM215TC3P4AF	215TC	SAE-A 2B FLANGE
5	-	DM215TC5M4DF	DM215TC5P4AF		
7 1/2	-	DM215TC7.5M4DF	DM215TC7.5P4AF		
10	-	DM215TC10M4DF	DM215TC10P4AF		
15	-	DM215TC15M4DF	DM215TC15P4AF		
20	-	DM215TC20M4DF	DM215TC20P4AF		

PUMPS GEAR TYPE

CODE	GPM	MODEL
4PS1.4	0,71	1.5 PE PAGE 68
4PS2.1	1,00	
4PS2.8	1,23	
4PS3.5	1,71	
2PE4.5	2,1	2 PE PAGE 69
2PE6.5	3,12	
2PE8.3	3,9	
2PE11.3	5,3	
2PE13.8	6,55	
2PE16	7,87	

VANE TYPE

CODE	GPM	MODEL
22S1	1,5	V10 PAGE 74
22S2	3,0	
22S3	4,5	
22S4	6,0	
22S5	7,5	
22S6	9,0	
22S7	10,5	V20 PAGE 74
22S8	12,0	
22S9	13,5	
22S10	15,0	
22S11	16,5	
22S12	18,0	
22S13	19,5	

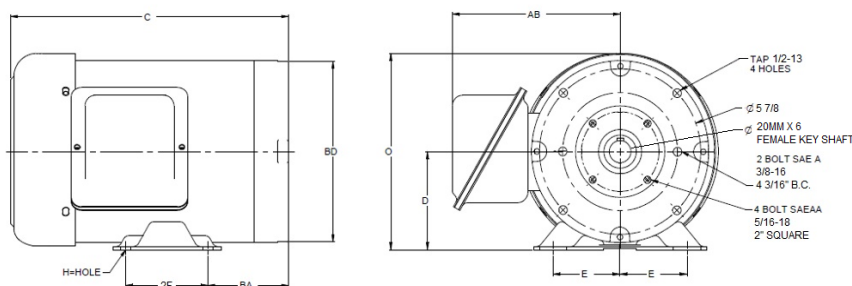

FRAME	DIMENSIONS (IN)									
	C	D	E	2F	H	O	BD	AB	BA	
56C	10.12	3.5	2.43	3.0	0.34 SLOTS	7.0	6.5 DIA	6.12	2.94	
215TC	15.62	5.25	4.25	7.0	0.40 DIA	11.0	8.5 DIA	8.38	3.5	

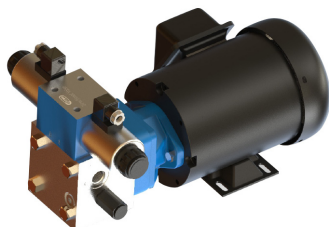

ALSO AVAILABLE

- HYDRAULIC CIRCUIT DIRECTLY MOUNTED ON THE PUMP
- VERY COMPACT DESIGN. LESS PIPING
- MANY OPTIONS
- OTHER OPTIONS AVAILABLE

ALUMINIUM GEAR PUMPS

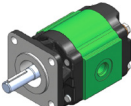

1.5PE
From 0.71 to 5.22 GPM
Up to 5000 RPM
Up to 3625 PSI

P.68



2PE
From 2.1 to 12.31 GPM
Up to 4000 RPM
Up to 3600 PSI

P.69



2.5PB
From 2.81 to 20.9 GPM
Up to 3000 RPM
Up to 3600 PSI

P.70



3PE
From 9.7 to 34.9 GPM
Up to 3000 RPM
Up to 3600 PSI

P.71

VANE PUMPS



V10/V20
From 1.5 to 19.5 GPM
Up to 4800 RPM
Up to 2500 PSI

P.74



25VQ/35VQ/45VQ
From 18 to 90 GPM
Up to 2700 RPM
Up to 3000 PSI

P.74



VARIABLE DISPLACEMENT
From 3 to 10.5 GPM
Up to 1800 RPM
Up to 1700 PSI

P.75

QUIET GEAR PUMPS



GR1
From 6.1 to 21.2 GPM
Up to 3000 RPM
Up to 3800 PSI

P.72

PISTON PUMPS



PPV VARIABLE DISPLACEMENT
From 28.5 to 61.8 GPM
Up to 2500 RPM
Up to 5433 PSI

P.78

CAST IRON GEAR PUMPS



PG330
From 6.1 to 21.2 GPM
Up to 3000 RPM
Up to 3800 PSI

P.73



BENT AXIS
From 6.1 to 21.2 GPM
Up to 3000 RPM
Up to 3800 PSI

P.78



PNC
From 38.58 to 71.3 GPM
Up to 3000 RPM
Up to 3500 PSI

P.73



A10V SWASHPLATE
From 8.5 to 66.5 GPM
Up to 3300 RPM
Up to 3000 PSI

P.79

OTHER PUMPS



PTO PUMP
From 7 to 22.5 GPM
Up to 1000 RPM
Up to 2000 PSI

P.78



PTO PUMP
From 11 to 19.2 GPM
Up to 540 RPM
Up to 3600 PSI

P.78



2 STAGE PUMPS
Up to 3600 RPM
Up to 3000 PSI

P.78

HAND PUMPS



HAND PUMP
Up to 3500 PSI

P.79



TPV 1100
Up to 3600 RPM
Up to 4350 PSI

P.80



TPV 1300
Up to 3600 RPM
Up to 4350 PSI

P.80



TPV 1500
Up to 3600 RPM
Up to 4350 PSI

P.81



TPV 3600
Up to 3600 RPM
Up to 5800 PSI

P.82



TPV 4300
Up to 3600 RPM
Up to 4060 PSI

P.82



TPV 5000
Up to 3600 RPM
Up to 4350 PSI

P.83

PTO



PTO
For transmissions and motors
SAE and DIN

P.78

1.5PE SERIE

- CLOCKWISE ROTATION
- 1/2 STRAIGHT KEY SHAFT

- ALSO AVAILABLE**
- COUNTERCLOCKWISE ROTATION
 - OTHER SHAFTS & FLANGES
 - TANDEM PUMPS & MULTIPLE PUMPS

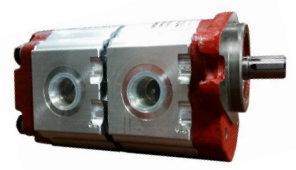
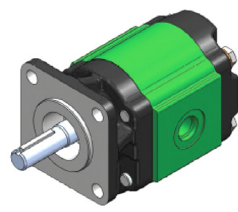

1.5PE TANDEM PUMP

MODEL CODE	DISPLACEMENT IN ³ (CM ³) / REV.	GPM @ 1800 RPM	MAX RPM	MAX PSI	PORT SIZE		MOUNTING	DIM "H" (IN)		
					INLET	OUTLET				
6109 1030 2	0.091 (1.4)	0.71	5000	3625	SAE-08	SAE-06	SAE-AA 2 BOLT	3.26		
6109 1050 2							SAE-AA 4 BOLT			
6109 1031 2	0.128 (2.1)	1.00	5000	3625			SAE-AA 2 BOLT	3.34		
6109 1051 2							SAE-AA 4 BOLT			
6109 1032 2	0.158 (2.8)	1.23	4500	3625			SAE-AA 2 BOLT	3.42		
6109 1052 2							SAE-AA 4 BOLT			
6109 1108 2	0.219 (3.5)	1.71	4500	3625			SAE-AA 2 BOLT	3.49		
6109 1053 2							SAE-AA 4 BOLT			
6109 1034 2	0.256 (4.1)	1.99	4000	3625			SAE-AA 2 BOLT	3.56		
6109 1054 2							SAE-AA 4 BOLT			
6109 1109 2	0.299 (5.2)	2.33	4000	3335			SAE-08	SAE-06	SAE-AA 2 BOLT	3.68
6109 1055 2									SAE-AA 4 BOLT	
6109 1036 2	0.354 (6.2)	2.76	3600	3140	SAE-AA 2 BOLT	3.79				
6109 1056 2					SAE-AA 4 BOLT					
6109 1110 2	0.457 (7.6)	3.56	3300	2900	SAE-AA 2 BOLT	3.95				
6109 1057 2					SAE-AA 4 BOLT					
6109 1038 2	0.57 (9.3)	4.44	3000	2610	SAE-AA 2 BOLT	4.14				
6109 1058 2					SAE-AA 4 BOLT					
6109 1039 2	0.67 (11)	5.22	3000	2465	SAE-AA 2 BOLT	4.33				
6109 1059 2					SAE-AA 4 BOLT					

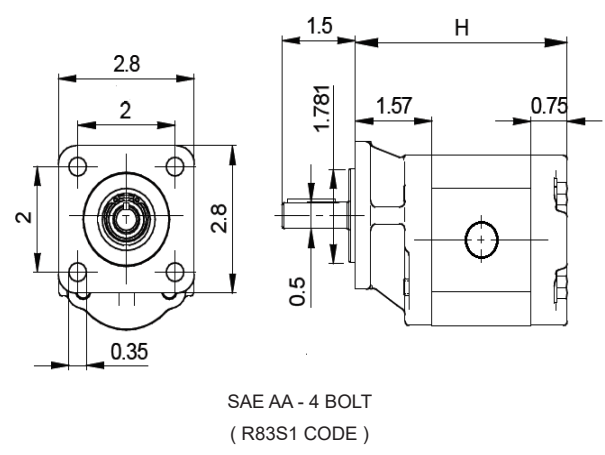
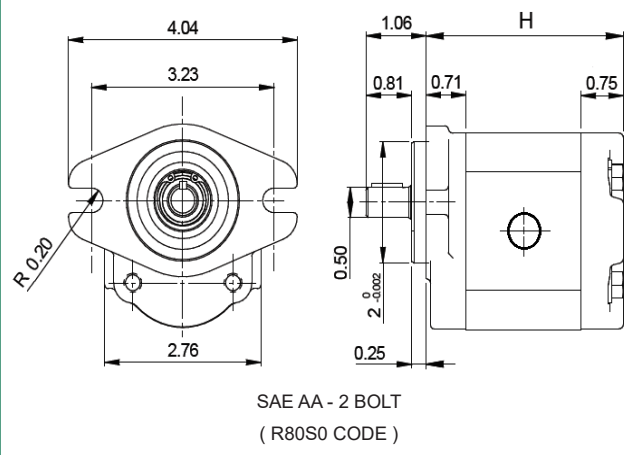

2PE SERIE

- CLOCKWISE ROTATION
- SAE-A 2 BOLT MOUNTING
- INLET: SAE-12 OUTLET: SAE-10

ALSO AVAILABLE

- COUNTERCLOCKWISE ROTATION
- OTHER SHAFTS & FLANGES
- TANDEM PUMPS & MULTIPLE PUMPS
- REAR COVERS WITH INTEGRATED VALVES
- OUTBOARD BEARING

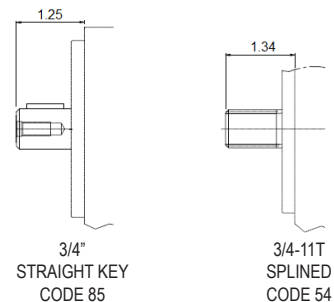
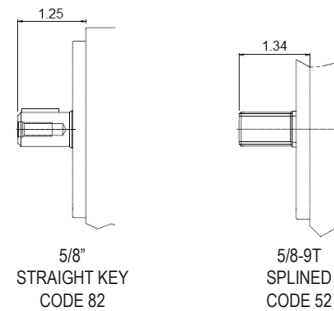
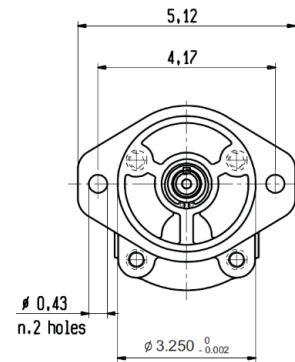
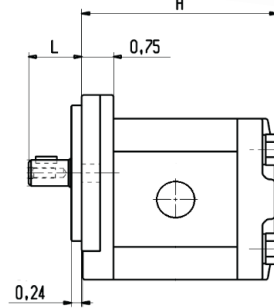
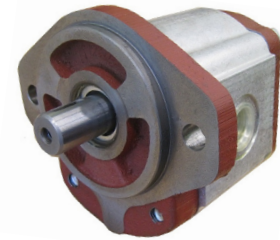

MODEL CODE	DISPLACEMENT IN ³ (CM ³) / REV.	GPM @ 1800 RPM	MAX RPM	MAX PSI	SHAFT	DIM "H" (IN)
6120 8164 2	0.27 (4.5)	2.1	4000	3600	5/8" STRAIGHT	2.58
6120 3372 2					5/8-9T SPLINE	
6120 3757 2					3/4" STRAIGHT	
6120 9594 2	0.40 (6.5)	3.12	4000	3600	5/8" STRAIGHT	2.72
6120 9596 2					5/8-9T SPLINE	
6120 9595 2					3/4" STRAIGHT	
6120 81662	0.50 (8.3)	3.9	3500	3600	5/8" STRAIGHT	2.82
6120 8055 2					5/8-9T SPLINE	
6120 3542 2					3/4" STRAIGHT	
6120 3475 2	0.68 (11.3)	5.3	3500	3600	3/4-11T SPLINE	3.10
6120 8167 2					5/8" STRAIGHT	
6120 7904 2					5/8-9T SPLINE	
6120 3543 2	0.84 (13.8)	6.55	3500	3600	3/4" STRAIGHT	3.25
6120 3512 2					3/4-11T SPLINE	
6120 8168 2					5/8" STRAIGHT	
6120 8056 2	1.01 (16)	7.87	3000	3600	5/8-9T SPLINE	3.40
6120 3544 2					3/4" STRAIGHT	
6120 3683 2					3/4-11T SPLINE	
6120 8169 2	1.15 (19)	8.96	3000	3140	5/8" STRAIGHT	3.72
6120 8309 2					5/8-9T SPLINE	
6120 3455 2					3/4" STRAIGHT	
6120 1808 2	1.37 (22.5)	10.68	2750	2900	3/4-11T SPLINE	3.94
6120 8170 2					5/8" STRAIGHT	
6120 7906 2					5/8-9T SPLINE	
6120 3456 2	1.58 (26)	12.31	2500	2600	3/4" STRAIGHT	4.17
6120 3514 2					3/4-11T SPLINE	
6120 8171 2					5/8" STRAIGHT	
6120 7907 2	1.58 (26)	12.31	2500	2600	5/8-9T SPLINE	4.17
6120 3276 2					3/4" STRAIGHT	
6120 3532 2					3/4-11T SPLINE	
6120 8172 2	1.58 (26)	12.31	2500	2600	5/8" STRAIGHT	4.17
6120 7908 2					5/8-9T SPLINE	
6120 3457 2					3/4" STRAIGHT	
6120 8066 2					3/4-11T SPLINE	

OTHER PORT CONNECTIONS

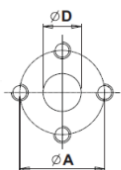

EUROPEAN FLANGE
CODE P

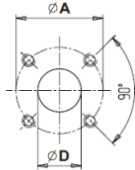

"BOSCH" FLANGE
CODE B

OTHER SHAFTS

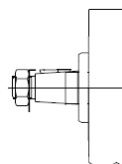

1:5 TAPERED CODE 25
1:8 TAPERED CODE 28

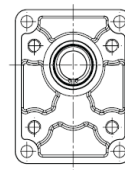

36.5MM PILOT DIA.
CODE P1

OTHER MOUNTING FLANGES

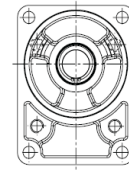

80MM PILOT DIA.
CODE B1



50MM PILOT DIA.
CODE B4/B5

2.5PB SERIE

- CLOCKWISE ROTATION
- SAE-B 2 BOLT MOUNTING

- ALSO AVAILABLE**
- SAE-A - 2 BOLT
 - COUNTERCLOCKWISE ROTATION
 - OTHER SHAFTS & FLANGES
 - TANDEM PUMPS & MULTIPLE PUMPS
 - REAR COVERS WITH INTEGRATED VALVE

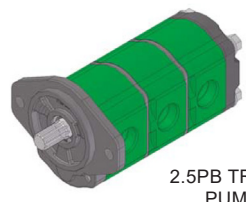
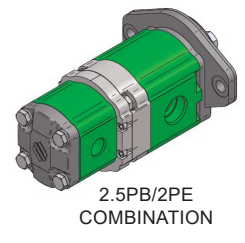

MODEL CODE	DISPLACEMENT IN ³ (CM ³) / REV.	GPM @ 1800 RPM	MAX RPM	MAX PSI	PORT SIZE		SHAFT	DIM "H" (IN)	
					INLET	OUTLET			
ONLY FOR MULTIPLE 2.5PB REAR PUMPS	0.36 (5.5)	2.81	3000	3600	SAE-12	SAE-10	-	4.02	
	0.50 (8.3)	3.88	3000	3600			-	4.12	
	6138 xxxx x 6138 7479 2	0.72 (11.5)	5.61	3000			3600	7/8" KEY	4.26
								7/8-13T SPLINE	
6138 xxxx x 6138 7470 2	0.86 (13.8)	6.7	3000	3600	SAE-12	SAE-10	7/8" KEY	4.35	
							7/8-13T SPLINE		
6138 7391 2 6138 7390 2	0.97 (16)	7.5	3000	3600	SAE-12	SAE-10	7/8" KEY	4.42	
							7/8-13T SPLINE		
6138 7393 2 6138 7392 2	1.17 (19)	9.1	3000	3600	SAE-12	SAE-10	7/8" KEY	4.56	
							7/8-13T SPLINE		
6138 7125 2 6138 7117 2	1.35 (22)	10.5	3000	3600	SAE-12	SAE-10	7/8" KEY	4.07	
							7/8-13T SPLINE		
6138 7373 2 6138 7372 2	1.53 (25)	11.9	3000	3600	SAE-16	SAE-12	7/8" KEY	4.79	
							7/8-13T SPLINE		
6138 7127 2 6138 7119 2	1.68 (28)	13	3000	3600	SAE-16	SAE-12	7/8" KEY	5.28	
							7/8-13T SPLINE		
6138 7128 2 6138 7120 2	1.97 (32)	15.3	3000	3300	SAE-16	SAE-12	7/8" KEY	5.49	
							7/8-13T SPLINE		
6138 7129 2 6138 7121 2	2.32 (38)	18	2750	2900	SAE-16	SAE-12	7/8" KEY	5.73	
							7/8-13T SPLINE		
6138 7130 2 6138 7122 2	2.69 (44)	20.9	2500	2465	SAE-16	SAE-12	7/8" KEY	6.03	
							7/8-13T SPLINE		

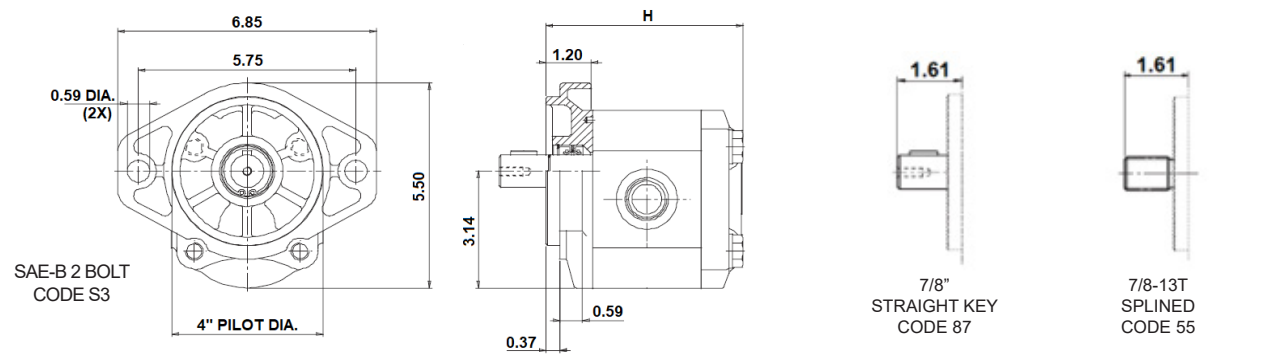

OTHER PORT CONNECTIONS



OTHER SHAFTS

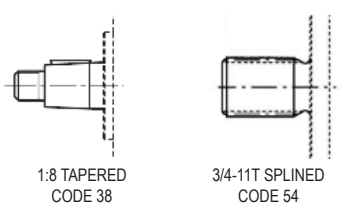

OTHER MOUNTING FLANGES

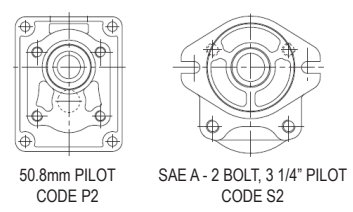

3PE SERIE

- CLOCKWISE ROTATION
- SAE-B 2 BOLT MOUNTING

ALSO AVAILABLE

- COUNTERCLOCKWISE ROTATION
- OTHER SHAFTS & FLANGES
- TANDEM PUMPS & MULTIPLE PUMPS
- REAR COVERS WITH INTEGRATED VALVE



3PE/2PE COMBINATION



MODEL CODE	DISPLACEMENT IN ³ (CM ³) / REV.	GPM @ 1800 RPM	MAX RPM	MAX PSI	PORT SIZE		SHAFT	DIM "H" (IN)
					INLET	OUTLET		
6130 1261 2	1.25 (21)	9.7	3000	3600	SAE-16	SAE-12	7/8" KEY	5.06
6130 1111 2							7/8-13T SPLINE	
6130 1262 2	1.65 (27)	12.8	3000	3600			7/8" KEY	5.26
6130 1112 2							7/8-13T SPLINE	
6130 1263 2	2.04 (33)	15.9	3000	3600			7/8" KEY	5.46
6130 1103 2							7/8-13T SPLINE	
6130 1264 2	2.36 (38)	18.4	3000	3600			7/8" KEY	5.61
6130 1113 2							7/8-13T SPLINE	
6130 1265 2	2.86 (46)	22.3	2750	3500	SAE-20	SAE-16	7/8" KEY	6.24
6130 7967 2							7/8-13T SPLINE	
6130 1266 2	3.30 (55)	25.7	2500	3190			7/8" KEY	6.48
6130 1104 2							7/8-13T SPLINE	
6130 1267 2	3.85 (65)	30	2500	2900			7/8" KEY	6.76
6130 1114 2							7/8-13T SPLINE	
6130 1268 2	4.48 (73.4)	34.9	2500	2610			7/8" KEY	7.03
6130 1115 2							7/8-13T SPLINE	

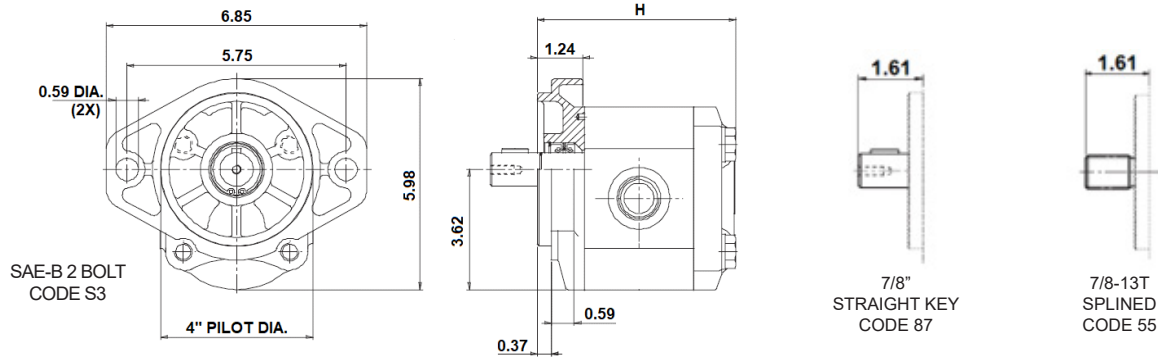

OTHER PORT CONNECTIONS

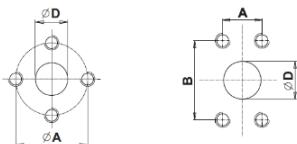

EUROPEAN FLANGE CODE P

CODE FLANGE 61 SALAMI CODE S

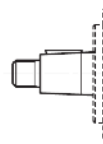

1.8 TAPERED CODE 38

OTHER SHAFTS

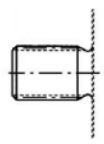

1-15T SPLINED CODE 56

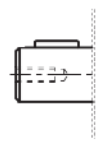

1" STRAIGHT KEY CODE 88

OTHER MOUNTING FLANGES

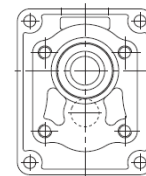

50.8mm PILOT CODE P2

QUIET GEAR PUMP 55DB

SETTIMAMECCANICA CONTINUUM® REPRESENTS THE NO NOISE ALTERNATIVE TO GEAR AND VANE PUMPS TO CREATE A BETTER WORKING ENVIRONMENT. PRODUCTS ARE IDEAL FOR HIGH PRESSURE APPLICATIONS DESIGNED WITH A NO NOISE PUMP TECHNOLOGY CAPABLE OF ELIMINATING ACOUSTIC EMISSIONS AND VIBRATIONS.



ADVANTAGES:

- SPECIAL ROTORS PROFILE AVOIDS OIL ENCAPSULATION
- **NO NOISE - AVERAGE 15DB (A) - LESS NOISE COMPARED TO STANDARD GEAR AND VANE PUMPS**
- EXTREMELY LOW VIBRATIONS AND PULSATIONS
- VERY HIGH EFFICIENCY FOR A WIDE RANGE OF SPEEDS (UP TO 6.500 RPM)
- MAXIMUM OPERATING PRESSURE UP TO 300 BAR
- INTERCHANGEABLE WITH STANDARD GEAR PUMPS

**NO NOISE
CONTINUUM®
TECHNOLOGY**

PARAMETERS:

PARAMETERS INFLUENCING EMISSIONS OF HYDRAULIC NOISE ARE:

- CAVITATION
- PRESSURE PEAKS RISING FROM TRAPPED FLUID BETWEEN GEAR TEETH
- RIPPLE OR FLOW PULSATION

DIFFERENTLY FROM TRADITIONAL GEAR PUMPS, THE PATENTED CONTINUUM® HELICAL ROTORS PROFILE DOES NOT TRAP ANY FLUID VOLUME, RESULTING IN A GENTLE FLUID TRANSMISSION AND AN OUTSTANDING REDUCTION OF PULSATIONS.

MODEL CODE	DISPLACEMENT IN ³ (CM ³) / REV.	GPM @1800 RPM	MAX RPM	MAX PSI	PORT SIZE		SHAFT	MOUNT
					INLET	OUTLET		
28-4.2AA2B10/08-1/2K	0.26 (4.2)	2.03	3600	3394	SAE-10	SAE-08	1/2" KEY	SAE-AA 2 BOLT
28-6.4AA2B10/08-1/2K	0.39 (6.4)	3.04		3394				
28-8.3AA2B10/08-1/2K	0.51 (8.3)	3.97		3031				
28-10.2AA2B10/08-1/2K	0.62 (10.2)	4.83		2741				
28-12.9AA2B10/08-1/2K	0.79 (12.9)	6.16		2466				
33-10.1A2B12/10-5/8K	0.62 (10.1)	4.83	3600	3989	SAE-12	SAE-10	5/8" KEY	SAE-A 2 BOLT
33-12.6A2B12/10-5/8K	0.77 (12.6)	6		3844				
33-15.2A2B12/10-5/8K	0.93 (15.2)	7.25		3495				
33-18.2A2B16/12-5/8K	1.11 (18.2)	8.65		2988				
38-15.9A2B16/12-5/8K	0.97 (15.9)	7.56	3600	3884	SAE-16	SAE-12	5/8" KEY	SAE-B 2 BOLT
38-17.92B16/12-5/8K	1.09 (17.9)	8.49		3582				
38-20A2B16/12-5/8K	1.09 (17.9)	9.51		3336				
38-22.1A2B16/12-5/8K	1.35 (22.1)	10.6		3220				
38-25.2A2B16/12-5/8K	1.54 (25.2)	12		2901				
38-28.3A2B16/12-5/8K	1.73 (28.3)	13.48		2611				

PG330 SERIE

- CLOCKWISE ROTATION
- SAE B -2/4 BOLT MOUNTING
- 7/8-13T SPLINED SHAFT

ALSO AVAILABLE

- COUNTERCLOCKWISE ROTATION
- OTHER SHAFTS & FLANGES
- TANDEM PUMPS & MULTIPLE PUMPS
- OUTBOARD BEARING

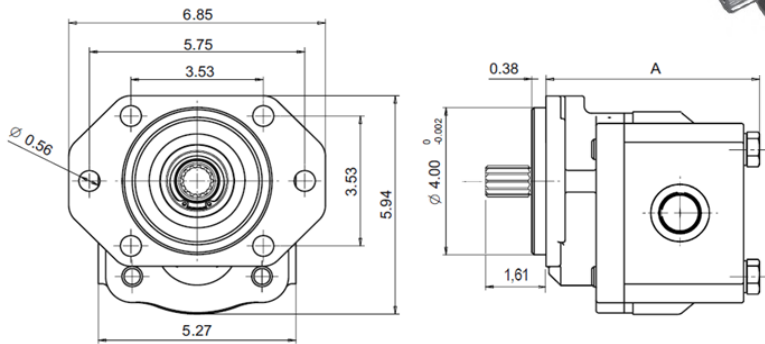
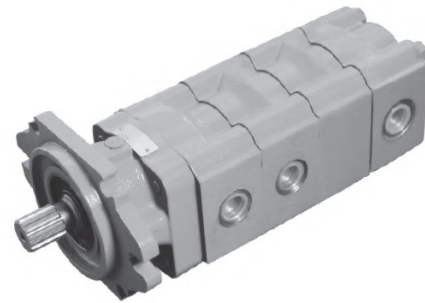

MODEL CODE	DISPLACEMENT IN ³ (CM ³) / REV.	GPM @ 1800 RPM	MAX RPM	MAX PSI	PORT SIZE		DIM "A" (IN)
					INLET	OUTLET	
6151 0000 2	1.43 (23)	6.1	3000	3800	SAE-16	SAE-12	5.54
6151 0001 2	1.74 (28)	7.5		4000			5.70
6151 0002 2	2.1 (34)	9		4000			5.88
6151 0003 2	2.46 (40)	10.6		3800			6.00
6151 0004 2	2.89 (47)	12.5	2700	4000	SAE-20	SAE-16	6.94
6151 0005 2	3.37 (55)	14.5		3800			7.18
6151 0006 2	3.92 (64)	16.9	2500	3500			7.45
6151 0007 2	4.48 (73)	19.2		3200			7.73
6151 0008 2	4.91 (80)	21.2		2900			7.96

PNC SERIE

- CLOCKWISE ROTATION
- SAE B -2/4 BOLT MOUNTING
- 1 1/4-14T SPLINED SHAFT

ALSO AVAILABLE

- SMALLER DISPLACEMENTS
- COUNTERCLOCKWISE ROTATION
- OTHER SHAFTS & FLANGES
- OUTBOARD BEARING
- TANDEM PUMPS & MULTIPLE PUMPS

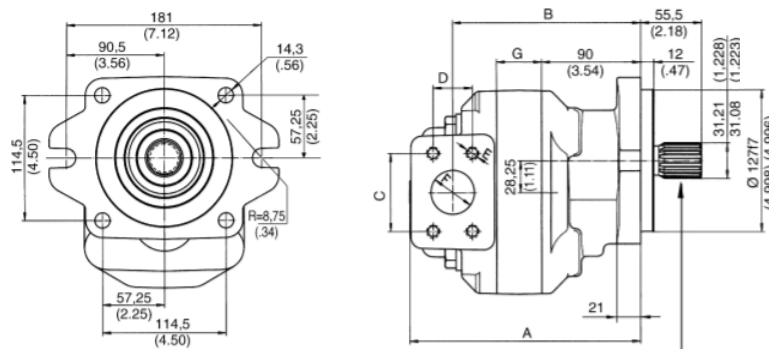
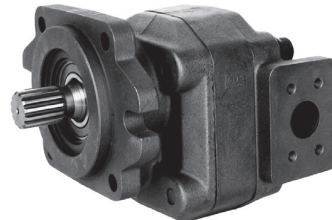

MODEL CODE	DISPLACEMENT IN ³ (CM ³) / REV.	GPM @ 1800 RPM	MAX RPM	MAX PSI	PORT SIZE		DIM "A" (IN)
					INLET	OUTLET	
1PNC 125 DG09M	5.08 (83)	39.5	3000	3500	1 1/2" CODE FLANGE 61 (M12 THREAD)	1 1/4" CODE FLANGE 61 (M10 THREAD)	8.83
1PNC 150 DG09M	6.1 (100)	47.5			9.17		
1PNC 175 DG09M	7.11 (116)	55.5	2500	3200	2" CODE FLANGE 61 (M12 THREAD)	1 1/2" CODE FLANGE 61 (M12 THREAD)	9.48
1PNC 200 DG09M	8.13 (133)	63.3	2000	2850			9.82
1PNC 225 DG09M	9.15 (150)	71.3	1750	2500			10.13

V10/V20 SERIES

- FULLY INTERCHANGEABLE WITH VICKERS

ALSO AVAILABLE

- NPT PORTS
- OTHER TYPE OF SHAFTS, PORTS
- COUNTERCLOCKWISE ROTATION
- PRIORITY REAR COVER



MODEL CODE	GPM @ 1800 RPM	MAX RPM	MAX PSI	PORT SIZE		SHAFT	MOUNTING				
				INLET	OUTLET						
V10-1S1S-1C20	1.5	4800	2500	SAE-16	SAE-08	3/4 KEY	SAE-A 2 BOLT				
V10-1S2S-1C20	3	4500									
V10-1S3S-1C20	4.5	4000									
V10-1S4S-1C20	6	3400									
V10-1S5S-1C20	7.5	3200									
V10-1S6S-1C20	9	3000	2200	SAE-20	SAE-12	3/4 KEY	SAE-A 2 BOLT				
V10-1P7S-1C20	10.5	2800	2000								
V20-1S7S-1C11	10.5	3000	2500					SAE-20	SAE-12	3/4 KEY	SAE-A 2 BOLT
V20-1S9S-1C11	13.5	2800									
V20-1S11S-1C11	16.5	2400									
V20-1P13P-1C11	19.5										

25VQ/35VQ/45VQ SERIES

- FULLY INTERCHANGEABLE WITH VICKERS

ALSO AVAILABLE

- OTHER TYPE OF SHAFTS, PORTS
- COUNTERCLOCKWISE ROTATION
- DOUBLE & TRIPLE PUMPS



MODEL CODE	GPM @ 1800 RPM	MAX RPM	MAX PSI	PORT SIZE		SHAFT	MOUNTING	
				INLET	OUTLET			
25VQ12A-1C20	18	2700	3000	1 1/2 CODE FLANGE 61	1" CODE FLANGE 61	7/8 KEY	SAE-B 2 BOLT	
25VQ14A-1C20	21							
25VQ17A-1C20	25							
25VQ21A-1C20	31.5	2500		2" CODE FLANGE 61	1 1/4 CODE FLANGE 61	1 1/4 KEY	SAE-C 2 BOLT	
35VQ25A-1C20	37.5							
35VQ30A-1C20	45	2400		2500	3" CODE FLANGE 61	1 1/2 CODE FLANGE 61	1 1/4 KEY	SAE-C 2 BOLT
35VQ35A-1C20	52.5							
35VQ38A-1C20	57							
45VQ42A-1C20	63	2200	2500		3" CODE FLANGE 61	1 1/2 CODE FLANGE 61	1 1/4 KEY	SAE-C 2 BOLT
45VQ50A-1C20	75							
45VQ60A-1C20	90							

VP VARIABLE DISPLACEMENT VANE PUMPS

- FULLY ADJUSTABLE FLOW AND PRESSURE COMPENSATOR. HIGH EFFICIENCY, LOW TEMPERATURE AND ENERGY-SAVING DESIGN
- VERY LOW NOISE, QUICK RESPONSE AND STEADY OPERATION
- ADJUSTMENT SCREWS FOR BOTH PRESSURE SETTING AND MAXIMUM FLOW SETTINGS

SPEED : MINIMUM : 800 RPM, MAXIMUM : 1800 RPM
 DRAIN MUST BE INSTALLED UNDER OIL LEVEL AND BELOW 7 PSI
 PIPE LENGTH SHOULD BE SHORTER THAN 3 FT
 INDEPENDENT RETURN LINE TO TANK REQUIRED

MODEL CODE

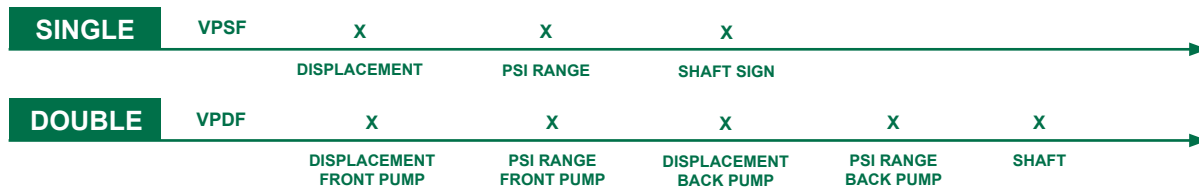

DISPLACEMENT

CODE	GPM @1800 RPM
12	3.17
15	3.96
20	5.28
30	7.93
40	10.56

PSI RANGE

CODE	PSI RANGE
A	140-280
B	215-500
C	425-780
D	710-1000

SHAFT

CODE	SHAFT
OMIT	PARALLEL KEY SHAFT
S	SPLINE SHAFT

SINGLE

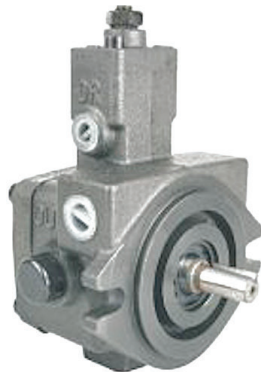

DOUBLE

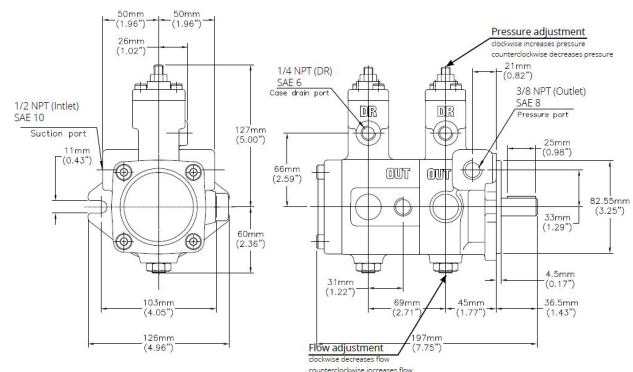
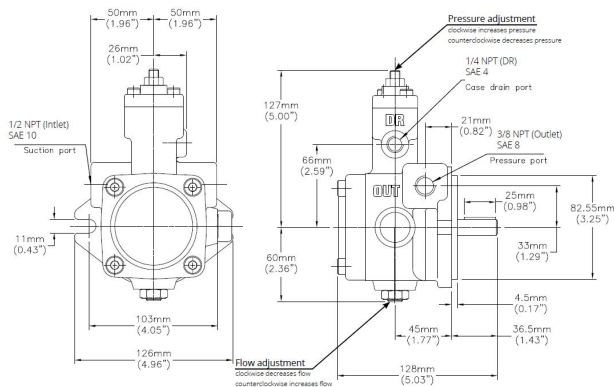

PPV LOAD SENSING VARIABLE DISPLACEMENT PUMPS

- SPECIFICALLY DESIGNED FOR THE NEEDS OF THE TRUCK MARKET
- WELL ADAPTED FOR APPLICATIONS IN : CRANES, REFUSE VEHICLES, SALT SPREADERS, SNOW EQUIPEMENT, CONSTRUCTION EQUIPEMENT AND TIPPER TRUCKS
- EXTREMELY COMPACT IN SIZE TO ALLOW DIRECT MOUNTING ON VEHICLE ENGINE OR PTO'S

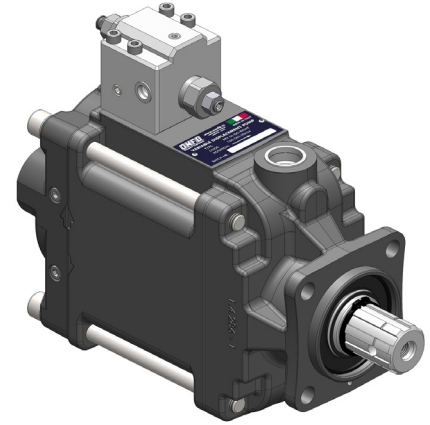

MODEL CODE	DISPLACMENT IN ³ (CM ³) / REV.	GPM @ 1800 RPM	MAX PSI	MAX RPM	MOUNTING FLANGE	SHAFT	PORT SIZE	ROTATION	OPTIONS
650 151 06LS1	3.66 (60)	28.5	5400 CONT. 5800 INT.	500 MIN 2500 CONT.	ISO 80MM 4B	DIN 5462	INLET: 50MM FLANGE	CW	- VOLUME STOP
650 151 06LS2					SAE-C 4B	1 1/4-14T SPLINE	OUTLET: SAE-16	CW	-
651 251 06LS1	5.59 (90)	43.6	5400 CONT. 5800 INT.	500 MIN 2300 CONT.	ISO 80MM 4B	DIN 5462	DRAIN: SAE-12	CW	- VOLUME STOP
650 151 09LS1					SAE-C 4B	1 1/4-14T SPLINE	OUTLET: SAE-16	CW	-
650 151 09LS2	6.71 (110)	52.3	5400 CONT. 5800 INT.	500 MIN 2200 CONT.	ISO 80MM 4B	DIN 5462	INLET: 50MM FLANGE	CW	- VOLUME STOP
651 251 11LS1					SAE-C 4B	1 1/4-14T SPLINE	OUTLET: SAE-16	CW	-
651 251 13LS2	7.90 (130)	61.8	5400 CONT. 5800 INT.	500 MIN 2100 CONT.	ISO 80MM 4B	DIN 5462	DRAIN: SAE-12	CW	VOLUME STOP
651 251 13LS7					SAE-C 4B	1 1/4-14T SPLINE	OUTLET: SAE-16	CCW	VOLUME STOP

SUCCION FITTINGS

MODEL CODE	DESCRIPTION
15511200507	ADAPTS 50MM FLANGE TO 2" ID SUCCION HOSE
15511200632	ADAPTS 50MM FLANGE TO 2 1/2" ID SUCCION HOSE
15611200767	ADAPTS 50MM FLANGE TO 3" ID SUCCION HOSE



HDS BENT AXIS FIXED DISPLACEMENT PUMPS

- BENT AXIS PISTON PUMP FOR TRUCKS
- 4 BOLT SAE B & SAE C MOUNTING
- FROM 0.73 IN (12 CC) TO 7.93 IN (130 CC)
- PRESSURES UP TO 6000 PSI



A10V VARIABLE DISPLACEMENT PUMPS

TECHNICAL SPECIFICATIONS

- SWASHPLATE AXIAL PISTON PUMP
- GOOD SUCTION CHARACTERISTICS
- COMPACT, LIGHTWEIGHT, LOW NOISE
- LONG SERVICE LIFE, HIGH PRECISION BEARINGS
- AXIAL AND RADIAL LOAD CAPACITY

MAXIMUM OPERATING PRESSURE

NOMINAL: 4060 PSI (280 BAR)
 INTERMITTENT: 4560 PSI (315 BAR)
 PEAK: 5075 PSI (350 BAR)
 MAXIMUM CASE DRAIN PRESSURE: 29 PSI (2 BAR)
 SUCCION PRESSURE RANGE: 11.6 - 435 PSI (0.8 - 30 BAR) ABSOLUTE



FEATURES

- PRESSURE COMPENSATOR WITH LOAD SENSE CONTROL (DFR)
- VOLUME STOP
- CLOCKWISE ROTATION
- SIDE PORTS WITH CODE 61 FLANGES
- BUNA SEALS

ALSO AVAILABLE

- MANY CONTROLS SUCH AS: REMOTE COMPENSATOR (DRG) AND COMPENSATOR WITH HORSEPOWER LIMITER (DFLR)
- COUNTERCLOCKWISE ROTATION
- END PORTS WITH CODE 61 OR 62 FLANGES
- VITON SEALS
- OTHER MOUNTING FLANGES AND SHAFTS

MODEL CODE	DISPLACEMENT IN ³ (CM ³) / REV.	GPM @ 1800 RPM	MAX RPM	MOUNTING FLANGE	SHAFT	PORTS CODE FLANGE 61	DRAIN PORT
A10VS018-DFR-31-R-P-K-C62N00	1.1 (18)	8.5	3300	SAE-A 2 BOLT	3/4" KEY	INLET: 1" OUTLET: 3/4"	SAE-06
A10VS018-DFR-31-R-P-S-C62N00					3/4 SPLINE		
A10VS028-DFR-31-R-P-K-C62N00	1.71 (28)	13	3000	SAE-B 2 BOLT	7/8" KEY	INLET: 1 1/4" OUTLET: 1"	SAE-08
A10VS028-DFR-31-R-P-S-C62N00					7/8" SPLINE		
A10VS045-DFR-31-R-P-K-C62N00	2.75 (45)	21	2600	SAE-B 2 BOLT	1" KEY	INLET: 1 1/2" OUTLET: 1"	SAE-10
A10VS045-DFR-31-R-P-S-C62N00					1" SPLINE		
A10VS071-DFR-31-R-P-K-C62N00	4.33 (71)	33.5	2200	SAE-C 2 BOLT	1 1/4" KEY	INLET: 2" OUTLET: 1"	SAE-10
A10VS071-DFR-31-R-P-S-C62N00					1 1/4" SPLINE		
A10VS0100-DFR-31-R-P-K-C62N00	6.10 (100)	47	2000	SAE-C 2 BOLT	1 1/2" KEY	INLET: 2 1/2"	SAE-12
A10VS0100-DFR-31-R-P-S-C62N00					1 1/2" SPLINE		
A10VS0140-DFR-31-R-P-K-C62N00	8.54 (140)	66.5	1800	SAE-D 4 BOLT	1 3/4" KEY	INLET: 2 1/2"	SAE-12
A10VS0140-DFR-31-R-P-S-C62N00					1 3/4" SPLINE		

PUMPS

PTO PUMPS

- SLIPS ONTO TRACTOR PTO SHAFT (NO GEARBOX REQUIRED)
- 2000 PSI MAXIMUM PRESSURE
- BARBED ADAPTOR FOR HOSE INCLUDED
- FEMALE PIPE ADAPTOR FOR 3/4 NPT INCLUDED

BAILEY PART NO	MODEL CODE	HP @ 2000 PSI	FLOW		SHAFT	PORTS SIZE
			@ RPM	GPM		
251560	HC-PTO-1A	32	540	21	1 3/8 - 6 T	INLET SAE-16
251555	HC-PTO-9A	27		17		
251563	HC-PTO-2A	18		11		OUTLET SAE-12
251565	HC-PTO-3A	34	1000	22.5	1 3/8 - 21 T	



GEAR BOX / PUMP ASSEMBLY

- SLIPS ONTO 540 RPM TRACTOR PTO SHAFTS
- ADAPTS TO 1 3/8 - 6T SPLINE SHAFT
- OTHER PUMPS FLOW AVAILABLE UPON REQUEST

MODEL CODE	HP @ 2000 PSI	GPM @ 540 RPM	MAX PSI	INLET	OUTLET
2.5PB-PTO-38D	25.4	19.2	2500	SAE-16	SAE-12
2.5PB-PTO-32D	21.4	16.3	3300		
2.5PB-PTO-22D	14.7	11	3600		

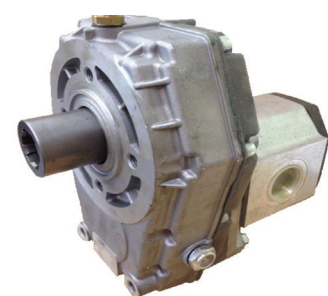

POWER TAKE-OFF

- NEW COMPLETE LINE ADAPTED TO YOUR NEED
- PTO'S WITH SAE B OUTPUT VERSION NOW AVAILABLE
- COMPATIBLE FOR FOLLOWING TRANSMISSIONS AND MOTORS : EATON, ALLISON, FORD, MACK, VOLVO AND OTHERS
- SEND US YOUR REQUESTS

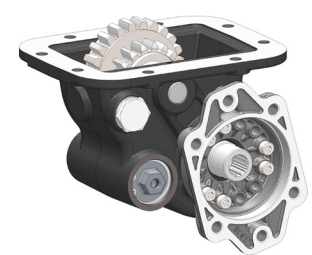

2 STAGES PUMPS

- IDEAL FOR LOGSPLITTERS
- CLOCKWISE ROTATION
- 3000 PSI MAXIMUM PRESSURE
- 3600 MAX RPM
- UNLOAD PRESSURE SET TO 650 PSI (400-900 PSI RANGE)
- 1" TUBE INLET

MODEL CODE	GPM @ 3600 RPM		SHAFT	MOUNTING FLANGE	OUTLET PORT
	HIGH SPEED LOW PRESSURE	LOW SPEED HIGH PRESSURE			
CBN-8.8/3.0	11	2.8	1/2 KEY	SAE-AA 4 BOLT	1/2 NPT
CBN-13/4.2	16	4			
CBDN-16/7	22	6	5/8 KEY	SAE-A 2 BOLT	3/4 NPT
CBDN-22/7	28	6			



HAND PUMPS

- TEMPERATURE -30° + 110° C (NBR)
- PORTS: SAE-06
- OPTIONS : MANUAL RELEASE, RELIEF VALVE, PRESSURE GAUGE

MODEL CODE

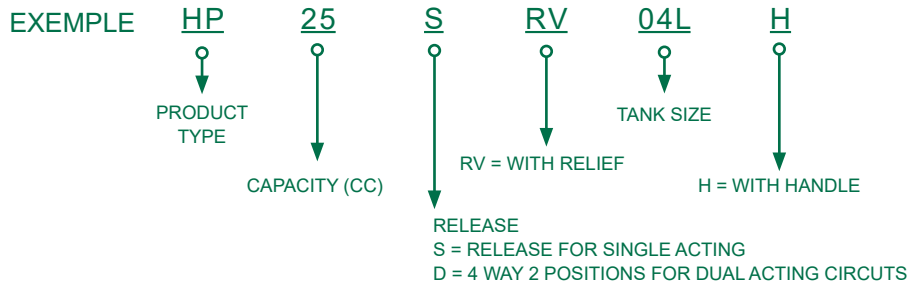

25 CC

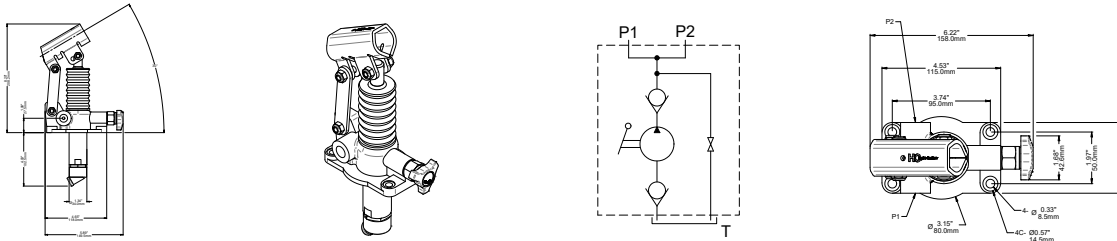

45 CC

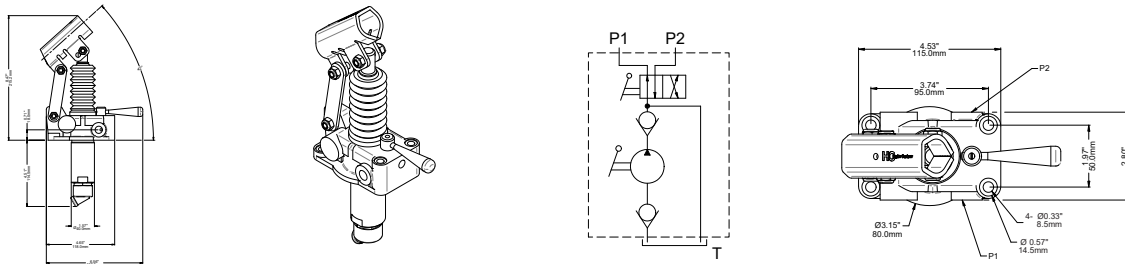

DISPLACEMENT (CC)	MAX PSI	FULL LOAD (CC)	PULL (CC)	PUSH (CC)
25	4351	25	13.4	11.6
45	3916	45	23.7	21.3

CAPACITY (LITER)	DIMENSIONS (MM)		
	A	B	C
1	150	100	120
1.5	150	100	120
2	150	100	185
3	150	100	255
5	175	175	200
7	175	175	275
10	175	175	380
16	230	230	350

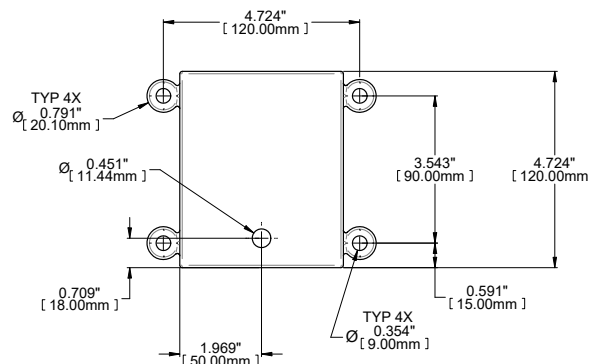
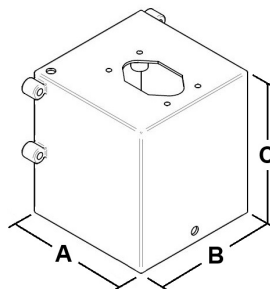

PUMPS

TPV 1100 VARIABLE DISPLACEMENT CLOSED LOOP SYSTEM AXIAL PISTON PUMPS

- FEATURES:**
- COMPACT DESIGN
 - SUITABLE FOR MULTIPLE PUMP ASSEMBLY
 - SAE A OR SAE B FLANGE
 - SPLINE AND KEYED SHAFTS AVAILABLE
 - BUILT-IN PRESSURE RELIEF VALVES
 - INTEGRATED CHARGE PUMP
- CONTROLS AVAILABLE:**
- DIRECT MECHANICAL CONTROL, LEVER OR NOT
 - CONTROL LEVER WITH SPRING RETURN TO NEUTRAL
 - INTEGRATED HYDRAULIC SERVO CONTROL
 - INTEGRATED ELECTRO-PROPORTIONAL SERVO CONTROL
- OPTIONS:**
- AUXILIARY GEAR PUMP
 - LEVER BY-PASS
 - FLUSHING VALVE
 - LEVER BY-PASS + PURGE VALVE
 - SCREW BY-PASS

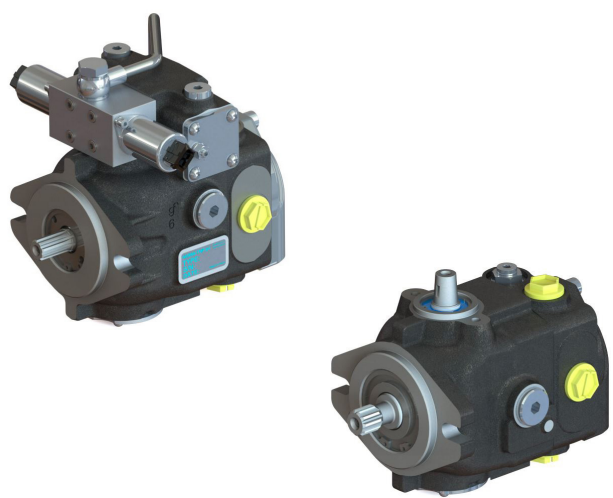

DISPLACEMENT IN ³ (CM ³) / REV.	RATED PRESSURE PSI	PEAK PRESSURE PSI	RATED SPEED RPM	WEIGHT LB (KG)
0.45 (7.4)	4350	5075	3600	24 (11)
0.54 (8.9)				
0.59 (9.6)				
0.68 (11.2)				
0.78 (12.8)				
0.83 (13.6)	3625	4350	2900	
0.91 (15.0)				
1.04 (17.1)				
1.11 (18.2)	3190	4060	2900	
1.18 (19.4)				
1.29 (21.1)				

TPV 1300 TANDEM PUMPS

- BASICALLY SAME TPV 1100 SPECIFICATIONS
- VERY COMPACT (BACK TO BACK PUMPS CONFIGURATION)

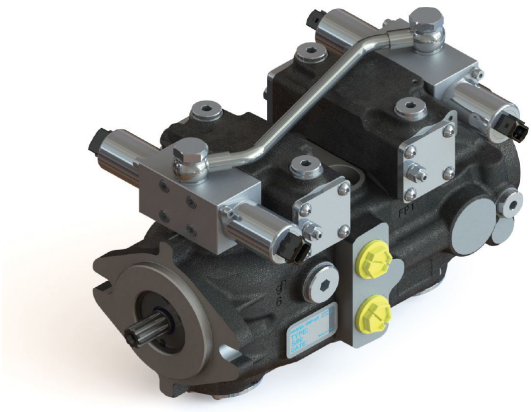

TPV 1500 VARIABLE DISPLACEMENT CLOSED LOOP SYSTEM AXIAL PISTON PUMP

FEATURES:

- COMPACT DESIGN
- HIGH POWER DENSITY
- SUITABLE FOR MULTIPLE PUMP ASSEMBLY
- SAE B MOUNT WITH 13T SPLINE SHAFT
- BUILT-IN PRESSURE RELIEF VALVES
- LOW NOISE INTEGRATED CHARGE PUMP

CONTROLS AVAILABLE:

- HYDRAULIC SERVO CONTROL
- ELECTRO-PROPORTIONAL SERVO CONTROL
- MECHANICAL LEVER SERVO CONTROL WITH FEEDBACK

OPTIONS:

- FEEDBACK ON CONTROLS
- PRE-ARRANGED FOR CONNECTION WITH EXTERNAL FILTER
- INTEGRATED FILTER WITH OR WITHOUT CLOGGING INDICATOR
- AUXILIARY GEAR PUMP
- FLUSHING VALVE WITH SCREW BY-PASS
- MAN ON BOARD
- SENSORS FOR RPM, ANGLE, PRESSURE

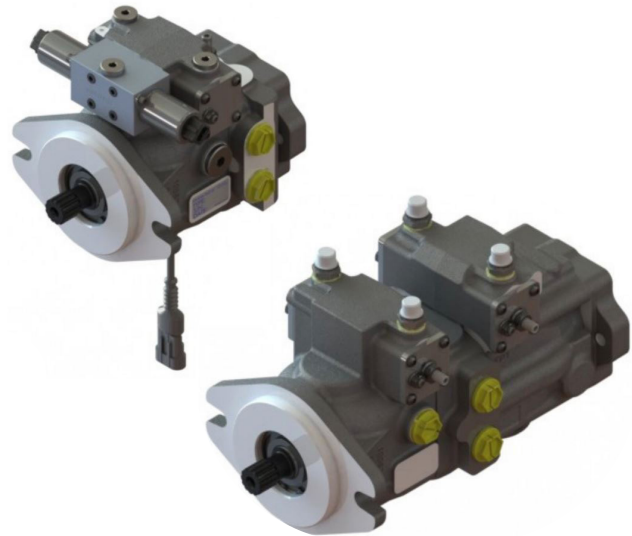

PUMPS

DISPLACEMENT IN ³ (CM ³) / REV.	RATED PRESSURE PSI	PEAK PRESSURE PSI	RATED SPEED RPM	WEIGHT LB (KG)
1.07 (17.6)	4350	5075	3600	31 (14)
1.14 (18.7)				
1.21 (19.9)				
1.29 (21.1)				
1.38 (22.7)	4060	4625		
1.46 (24.0)				

TPV 3600 VARIABLE DISPLACEMENT CLOSED LOOP SYSTEM AXIAL PISTON PUMPS

- FEATURES:**
- COMPACT DESIGN
 - SUITABLE FOR MULTIPLE PUMP ASSEMBLY
 - SAE B MOUNT WITH 13T OR 15T SPLINE SHAFT
 - BUILT-IN PRESSURE RELIEF VALVES
 - LOW NOISE INTEGRATED CHARGE PUMP
- CONTROLS AVAILABLE:**
- HYDRAULIC SERVO CONTROL
 - ELECTRO-PROPORTIONAL SERVO CONTROL
 - MECHANICAL LEVER SERVO CONTROL WITH FEEDBACK
- OPTIONS:**
- AUXILIARY GEAR PUMP
 - FEEDBACK ON CONTROLS
 - PRE-ARRANGED FOR CONNECTION WITH EXTERNAL FILTER
 - INTEGRATED FILTER WITH OR WITHOUT CLOGGING INDICATOR
 - FLUSHING VALVE WITH SCREW BY-PASS
 - MAN ON BOARD
 - SENSORS FOR RPM, ANGLE, PRESSURE

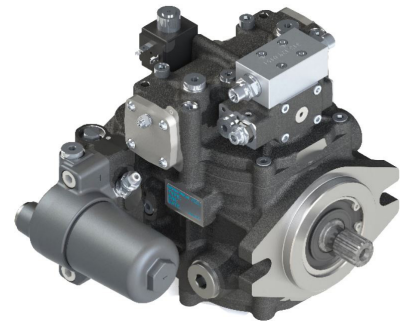

DISPLACEMENT IN ³ (CM ³) / REV.	RATED PRESSURE PSI	PEAK PRESSURE PSI	RATED SPEED RPM	WEIGHT LB (KG)
1.6 (26)	5800	6100	3600	57 (28)
1.7 (28)				
1.8 (30)				
1.9 (31)				
2.0 (32)				
2.1 (34)				
2.2 (36)				
2.3 (38)				
2.6 (43)				

TPV 4300 VARIABLE DISPLACEMENT CLOSED LOOP SYSTEM AXIAL PISTON PUMPS

- FEATURES:**
- COMPACT DESIGN
 - SUITABLE FOR MULTIPLE PUMP ASSEMBLY
 - SAE B MOUNT WITH 13T OR 15T SPLINE SHAFT
 - BUILT-IN PRESSURE RELIEF VALVES
 - LOW NOISE INTEGRATED CHARGE PUMP
- CONTROLS AVAILABLE:**
- HYDRAULIC SERVO CONTROL
 - ELECTRO-PROPORTIONAL SERVO CONTROL
 - ELECTRIC ON-OFF SERVO CONTROL
 - MECHANICAL LEVER SERVO CONTROL WITH FEEDBACK
- OPTIONS:**
- AUXILIARY GEAR PUMP
 - FEEDBACK ON CONTROLS
 - PRE-ARRANGED FOR CONNECTION WITH EXTERNAL FILTER
 - SCREW BY-PASS
 - MAN ON BOARD
 - PRESSURE CUT-OFF VALVE



DISPLACEMENT IN ³ (CM ³) / REV.	RATED PRESSURE PSI	PEAK PRESSURE PSI	RATED SPEED RPM	WEIGHT LB (KG)
2.0 (32)	4060	4625	3600	53 (24)
2.3 (38)				
2.7 (45)				
3.1 (50)				

TPV 5000 VARIABLE DISPLACEMENT CLOSED LOOP SYSTEM AXIAL PISTON PUMPS

FEATURES:

- COMPACT DESIGN
- SUITABLE FOR MULTIPLE PUMP ASSEMBLY
- SAE B MOUNT WITH 13T OR 15T SPLINE SHAFT
- BUILT-IN PRESSURE RELIEF VALVES

CONTROLS AVAILABLE:

- AUTOMOTIVE
- HYDRAULIC PROPORTIONAL
- ELECTRIC 2 POSITION ON-OFF
- ELECTRIC IMPULSE
- ELECTRO-PROPORTIONAL
- MECHANICAL LEVER SERVO CONTROL WITH FEEDBACK

OPTIONS:

- AUXILIARY GEAR PUMP
- FEEDBACK ON CONTROLS
- POWER LIMITER
- PRESSURE FILTER
- PRE-ARRANGED FOR CONNECTION WITH EXTERNAL FILTER
- INTEGRATED FILTER WITH OR WITHOUT CLOGGING INDICATOR
- ELECTRIC CUT-OFF VALVE
- HYDRAULIC AND MECHANICAL INCHING

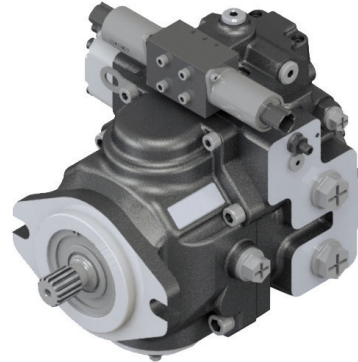

DISPLACEMENT IN ³ (CM ³) / REV.	RATED PRESSURE PSI	PEAK PRESSURE PSI	RATED SPEED RPM	WEIGHT LB (KG)
2.8 (46)	4350	5800	3600	64 (29)
3.1 (50)				
3.9 (64)				



BM20

SPOOL : 1-7

FLOW : 5.2 GPM

MAX PRESSURE : 4700 PSI P.86



BF40

SPOOL : 1-6

FLOW : 10.5 GPM

MAX PRESSURE : 4700 PSI P.90



MB2

SPOOL : 1

FLOW : 12 GPM

MAX PRESSURE : 3600 PSI P.86



MB3

SPOOL : 2-7

FLOW : 12 GPM

MAX PRESSURE : 4600 PSI P.86



VDM6A

SPOOL : 1-7

FLOW : 12 GPM

MAX PRESSURE : 5400 PSI P.88



VDM6

FLOW : 15 GPM

MAX PRESSURE : 5000 PSI P.87



MB4

SPOOL : 1-6

FLOW : 16 GPM

MAX PRESSURE : 4600 PSI P.88



BF70

SPOOL : 1-6

FLOW : 18.5 GPM

MAX PRESSURE : 4700 PSI P.90



RD500 & RD2500
 SPOOL : 1-3
 FLOW : 20 GPM
 MAX PRESSURE : 3000 PSI P.89



MB5
 SPOOL : 1-6
 FLOW : 21 GPM
 MAX PRESSURE : 4600 PSI P.88



BF90
 SPOOL : 1
 FLOW : 24 GPM
 MAX PRESSURE : 4700 PSI P.90



VDM8
 SPOOL : 1-5
 FLOW : 24 GPM
 MAX PRESSURE : 5000 PSI P.90



BM100
 SPOOL : 1-3
 FLOW : 26 GPM
 MAX PRESSURE : 4700 PSI P.91



BM150/180
 SPOOL : 1
 FLOW : 40 / 48 GPM
 MAX PRESSURE : 4700 PSI P.91



TIPPING VALVES
 FLOW : MODULAR 150/200/250
 MAX PRESSURE : 5800 PSI P.91

BM20 MANUAL VALVES

- ZINC COATED
- DOUBLE ACTING SPOOL, SPRING RETURN WITH LEVERS
- OPEN/CLOSED CENTER, POWER BEYOND OPTION
- HANDLES INCLUDED
- RELIEF SET TO 2550 PSI

MODEL CODE	NB OF SPOOL	GPM MAX	PSI MAX	PORT SIZE
902457	1	5.2	4700	P, T, A, B: SAE-06 P2 & T2: SAE-08
902458	2			
902459	3			
90211008	4			
90211009	5			
90211010	6			
90211011	7			



MB2 MANUAL VALVES

- BLACK PAINTED
- DOUBLE ACTING SPOOL, SPRING RETURN WITH LEVERS
- HANDLES INCLUDED
- RELIEF SET TO 2550 PSI
- OPEN CENTER ONLY, NO POWER BEYOND

MODEL CODE	NB OF SPOOL	GPM MAX	PSI MAX	PORT SIZE
MB2/1S-3/18L/E8-M1	1	12	3600	SAE-08

FITS "SD4"
WALVOIL FOOTPRINT



MB3 MANUAL VALVES

- BLACK PAINTED
- DOUBLE ACTING SPOOL, SPRING RETURN WITH LEVERS
- OPEN/CLOSED CENTER. POWER BEYOND OPTION
- HANDLES INCLUDED
- RELIEF SET TO 2550 PSI

MODEL CODE	NB OF SPOOL	MAX GPM	MAX PSI	PORT SIZE
MB3/1S-3/18L/E8-M3	1	12	4600	SAE-08
MB3/2S-3/18L/E8-M3	2			
MB3/3S-3/18L/E8-M3	3			
MB3/4S-3/18L/E8-M3	4			
MB3/5S-3/18L/E8-M3	5			
MB3/6S-3/18L/E8-M3	6			
MB3/7S-3/18L/E8-M3	7			

FITS "SD5"
WALVOIL FOOTPRINT



ALSO AVAILABLE

- MOTOR AND SINGLE ACTING SPOOLS
- 2 AXIS JOYSTICK
- DETENT, FLOAT CONTROL
- ELECTRIC, AIR & CABLE CONTROLS
- LIMIT SWITCH

VDM6 MANUAL VALVES

- ZINC COATED
- DOUBLE ACTING SPOOL, SPRING RETURN WITH LEVERS
- OPEN / CLOSED CENTER, POWER BEYOND OPTION
- HANDLES INCLUDED
- RELIEF SET AT 2550 PSI
- VERY GOOD METERING
- MINIMAL TOLERANCE BETWEEN PARTS FOR MINIMUM INTERNAL LEAKAGE
- SEVERAL TYPE OF SPOOLS AND CONTROLS



623100131

MODEL CODE	NB OF SPOOL	MAX GPM	MAX PSI	PORT SIZE
623100111	1	15	5000	P, A & B: SAE-08 T: SAE-10
623100121	2			
623100131	3			
623100141	4			
623100151	5			
623100161	6			
623105501	7			

OTHER POPULAR VALVES

MODEL CODE	DESCRIPTION
623108010	1 D.A. SPOOL, 12VDC WITH LEVERS
623106980	2 D.A. SPOOLS, 12VDC WITH LEVERS
623106330	1 D.A. DETENT KICK-OUT SPOOL, 1 S.A SPOOL
623103870	1 FLOATING + 1 D.A. SPOOL C/W JOYSTICK
623108191	7 SPOOL D.A C/W 2 JOYSTICKS SAE-06 ON A & B PORTS



623108191

POPULAR PARTS

MODEL CODE	DESCRIPTION
R23400320	DETENT KIT IN & OUT
R23400210	SPOOL SEAL KIT (PER SPOOL)
R23400221	SPRING RETURN KIT
R23400060	LEVER BOX
795428901	POWER BEYOND & CLOSE CENTER PLUG

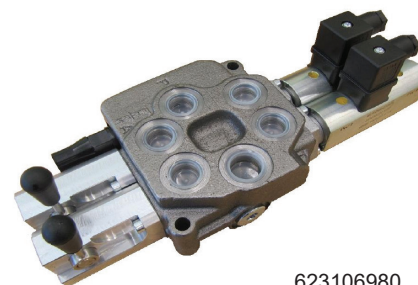

623106980

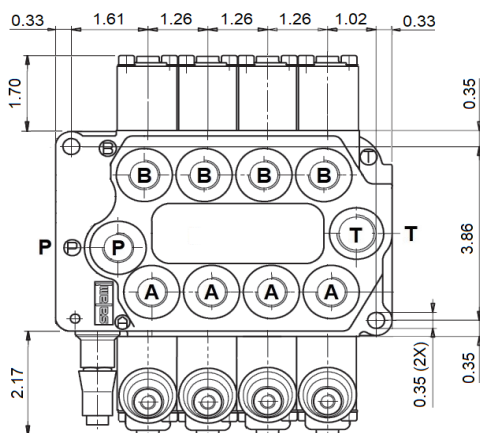

VDM6A MANUAL VALVES

- LOADCHECK ON EVERY SECTION
- POSSIBILITY FOR PORT RELIEFS
- DOUBLE ACTING SPOOL, SPRING RETURN WITH LEVERS
- OPEN/CLOSED CENTER. POWER BEYOND OPTION
- HANDLES INCLUDED
- RELIEF SET TO 2550 PSI

MODEL CODE	NB OF SPOOLS	MAX GPM	MAX PSI	PORT SIZE
625033600	2	12	5400	P, A & B: SAE-08 T: SAE-10
625033700	3			
625033800	4			
625034100	5			
625034200	6			
625034300	7			



MB4 MANUAL VALVES

- BLACK PAINTED
- DOUBLE ACTING SPOOL, SPRING RETURN WITH LEVERS
- OPEN/CLOSED CENTER. POWER BEYOND OPTION
- HANDLES INCLUDED
- RELIEF SET TO 2550 PSI
- MANY OPTIONS AVAILABLE

MODEL CODE	NB OF SPOOLS	MAX GPM	MAX PSI	PORT SIZE
MB4/1S-3/18L/E8-M3	1	16	4600	SAE-08
MB4/2S-3/18L/E8-M3	2			
MB4/3S-3/18L/E8-M3	3			
MB4/4S-3/18L/E8-M3	4			
MB4/5S-3/18L/E8-M3	5			

FITS "HCD10"
HYDROCONTROL
FOOTPRINT

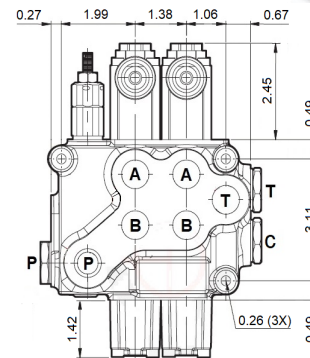

MB5 MANUAL VALVES

- BLACK PAINTED
- DOUBLE ACTING SPOOL, SPRING RETURN WITH LEVERS
- OPEN/CLOSED CENTER. POWER BEYOND OPTION
- HANDLES INCLUDED
- RELIEF SET TO 2550 PSI
- MANY OPTIONS AVAILABLE

MODEL CODE	NB OF SPOOLS	MAX GPM	MAX PSI	PORT SIZE
MB5/1S-3/18L/E8-M3	1	21	4600	P&T:SAE-12 A&B:SAE-10
MB5/2S-3/18L/E8-M3	2			
MB5/3S-3/18L/E8-M3	3			
MB5/4S-3/18L/E8-M3	4			
MB5/5S-3/18L/E8-M3	5			
MB5/6S-3/18L/E8-M3	6			

FITS "SD11"
WALVOIL FOOTPRINT

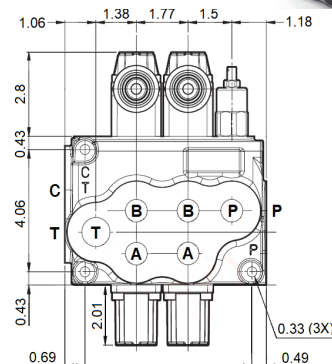

RD2500 & RD500 MANUAL VALVES - PRINCE

- 3000 PSI MAX PRESSURE
- DOUBLE ACTING SPOOLS
- LEVER BOX INCLUDED
- ADJUSTABLE RELIEF 1000-3000 PSI (SET TO 1500 PSI)



BAILEY PART NO	MODEL CODE	NB. OF SPOOLS	MAX GPM	PORT SIZE	DESCRIPTION	PARKER EQUIVALENT	WEIGHT (LBS)
220113	RD2575-T4-ESA1	1	20	P&T: 3/4 NPT A&B: 1/2 NPT	SPRING RETURN	400	9
220109	RD2575-T4-EDA1				3 POSITION DETENT	410	
220110	RD512CA5A4B1	1	30		SPRING RETURN	SP-4-HP	15
220522	RD522CCAA5A4B1	2				SP-4-4-HP	24
220532	RD532CCCAA5A4B1	3				SP-4-4-4-HP	37

LOG SPLITTER VALVES - PRINCE

- DOUBLE ACTING SPOOLS
- LEVER BOX INCLUDED
- ADJUSTABLE RELIEF UP TO 2750 PSI (SET TO 2250 PSI)
- PRESSURE RELEASE DETENT ADJUSTABLE FROM 1000-2000 PSI



LS-3000

BAILEY PART NO	MODEL CODE	NB. OF SPOOLS	MAX GPM	PSI MAX	PORT SIZE	DESCRIPTION	WEIGHT (LBS)
220092	LS-3000-1	1	25	2750	P&T: 3/4 NPT A&B: 1/2 NPT	PRESSURE RELEASE DETENT, SPOOL OUT POSITION	10
220093	LS-3000-2				3/4 NPT		
220090	LSR-3060-3				P&T: 3/4 NPT A&B: 1/2 NPT	HIGH SPEED EXTENSION (REGEN) PRESSURE RELEASE DETENT, SPOOL OUT POSITION	
	RD525MMEE5A4B1	2	30	3000	P&T: SAE-12 A&B: SAE-10	AUTO-CYCLE C/W POWER BEYOND	23

LOG SPLITTER VALVES - CHIEF

- DOUBLE ACTING SPOOLS
 - LEVER BOX INCLUDED
- LSV18N MODEL**
- ADJUSTABLE RELIEF 1000-3000 PSI (SET TO 1800 PSI)
 - NON ADJUSTABLE PRESSURE RELEASE DETENT SET TO 800 PSI
- LSV25N MODEL**
- ADJUSTABLE RELIEF 1000-2750 PSI (SET TO 2250 PSI)
 - PRESSURE RELEASE DETENT ADJUSTABLE FROM 1000-2600 PSI (SET TO 1400 PSI)



LSV18N

LSV25N

BAILEY PART NO	MODEL CODE	NB. OF SPOOLS	MAX GPM	PSI MAX	PORT SIZE	DESCRIPTION	WEIGHT (LBS)
220997	LSV18N	1	18	3000	P&T: 3/4 NPT A&B: 1/2 NPT	PRESSURE RELEASE DETENT, SPOOL OUT POSITION	5
220998	LSV25N		25	2750			10

BM100 MANUAL VALVES

- ZINC COATED
- DOUBLE ACTING SPOOL, SPRING RETURN WITH LEVERS
- OPEN/CLOSED CENTER. POWER BEYOND OPTION
- HANDLES INCLUDED
- RELIEF SET TO 2550 PSI

MODEL CODE	NB OF SPOOLS	MAX GPM	MAX PSI	PORT SIZE
93011006	1	26	3600	SAE-12
93011008	2			
93011009	3			

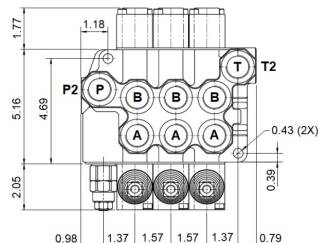

BM150/180 MANUAL VALVES

- 1 SPOOL VALVE
- ZINC COATED
- DOUBLE ACTING SPOOL, SPRING RETURN WITH LEVERS
- OPEN/CLOSED CENTER. POWER BEYOND OPTION
- HANDLES INCLUDED
- RELIEF SET TO 2550 PSI
- SPECIALLY DESIGNED FOR WINCHES
- AVAILABLE WITH ROTARY LEVERS

MODEL CODE	MAX GPM	MAX PSI	PORT SIZE	ROTARY LEVER
92511004	40	4700	P, T, A & B : SAE-12	X
925164			P2 & T2 : SAE-16	□
925603	48		SAE-16	X
925604				□



MODULAR 150/200/250 TIPPING VALVES

- GALVANIZED BODY AND NICKEL SPOOL
- BUILT-IN CHECK AND ADJUSTABLE SAFETY VALVES (DIRECT TYPE)
- MECHANICAL DIRECT END-OF-STROKE WITH ANTI-SHOCK SPRING
- MODULAR CAST-IRON BODY FOR PRESSURE UP TO 5801 PSI

MODEL CODE	NB OF SPOOLS	MAX GPM	MAX PSI	PORT SIZE
121-008-50372	1	40	5800	SAE-12
121-922-00517	1	66	5800	SAE-16

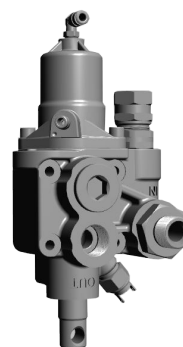

BM250 TIPPING VALVE

- MODULAR CAST-IRON BODY FOR PRESSURE UP TO 5801 PSI
- GALVANIZED BODY AND NICKEL SPOOL

MODEL CODE	NB OF SPOOLS	MAX GPM	MAX PSI	PORT SIZE
121-015-00104	1	66	5800	SAE-12

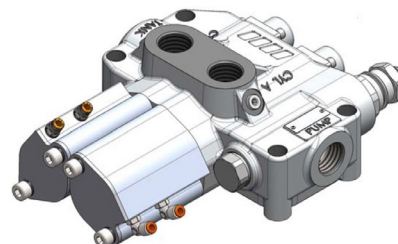



VD6A

SPOOL : 1-8
MAX GPM : 12
MAX PSI : 5100

----- P.93



SN-3

SPOOL : 1-12
MAX GPM : 1
MAX PSI : 4600

----- P.97



VD8A

SPOOL : 1-8
MAX GPM : 20
MAX PSI : 5100

----- P.94



SN-4

SPOOL : 1-12
MAX GPM : 21
MAX PSI : 4600

----- P.97



SN-5

SPOOL : 1-12
MAX GPM : 32
MAX PSI : 4600

----- P.97



VD10A

SPOOL : 1-8
MAX GPM : 97
MAX PSI : 4000

----- P.95



SN-6

SPOOL : 1-12
MAX GPM : 37
MAX PSI : 4600

----- P.97



VD12A

SPOOL : 1-8
MAX GPM : 63
MAX PSI : 4000

----- P.96



SN-8

SPOOL : 1-12
MAX GPM : 63
MAX PSI : 4600

----- P.97

VD6A MANUAL VALVES

- VERY GOOD METERING
- MINIMAL TOLERANCE BETWEEN PARTS FOR MINIMUM INTERNAL LEAKAGE
- PARALLEL CIRCUIT (SERIE AND TANDEM SECTIONS AVAILABLE)
- LOAD CHECK ON EACH SECTION
- SEVERAL TYPE OF SPOOLS AND CONTROLS
- POSSIBLY TO ADD PORT RELIEF WITH OR WITHOUT ANTI-CAVITATION
- HANDLES INCLUDED
- WE CAN ASSEMBLE AND CUSTOMIZE FOR YOU



MODEL CODE	SECTIONS	MAX GPM	MAX PSI	PORT SIZE
VD6A	1 - 8	16	5000	P & T: SAE-10 A & B: SAE-08

COMPONENTS

MODEL CODE	TYPE	DESCRIPTION
R23470090	INLET	RELIEF SET TO 2750 PSI
S23470070	SECTION	DOUBLE ACTING, SPRING RETURN, LEVER
S23480550		MOTOR, SPRING RETURN, LEVER
S23480820		SINGLE ACTING PORT A, SPRING RETURN, LEVER
S23480270		4TH POSITION FLOAT, SPRING RETURN, LEVER
S23480542		DOUBLE ACTING, 12V, EMERGENCY LEVER (10.6 GPM MAX)
S23480480		SERIE, DOUBLE ACTING, SPRING RETURN, LEVER
S23480970		TANDEM, DOUBLE ACTING, SPRING RETURN, LEVER
R23490030		OUTLET
R23400610	ASSY KIT	1 SECTION
R23400620		2 SECTIONS
R23400630		3 SECTIONS
R23400640		4 SECTIONS
R23400650		5 SECTIONS
R23400660		6 SECTIONS
R23400670		7 SECTIONS
R23400680		8 SECTIONS

PARTS

MODEL CODE	DESCRIPTION
795429200	POWER BEYOND PLUG OR CLOSED CENTER
R23400320	DETENT KIT IN & OUT R2
R23400280	DETENT KIT OUT R4
R23400250	DETENT KIT IN R5
R23400033	JOYSTICK KIT
R20289960	JOYSTICK HANDLE
R360T0600	CABLE ADAPTOR KIT
R23400100	PNEUMATIC CONTROL KIT
796370700	PORT RELIEF 290 - 725 PSI
796370701	PORT RELIEF 740 - 1305 PSI
796370702	PORT RELIEF 1320 - 1885 PSI
796370703	PORT RELIEF 1900 - 2970 PSI
796370704	PORT RELIEF 2985 - 4060 PSI
796370725	PORT RELIEF + ANTI-CAVITATION 1900 - 2970 PSI
796270726	PORT RELIEF + ANTI-CAVITATION 2985 - 3985 PSI
R25000650	ANTI-CAVITATION VALVE
R23400060	LEVER BOX
420192000	HANDLE
R23400221	SPRING RETURN
R23400210	SPOOL SEAL KIT
R23400200	SIDE SEAL KIT

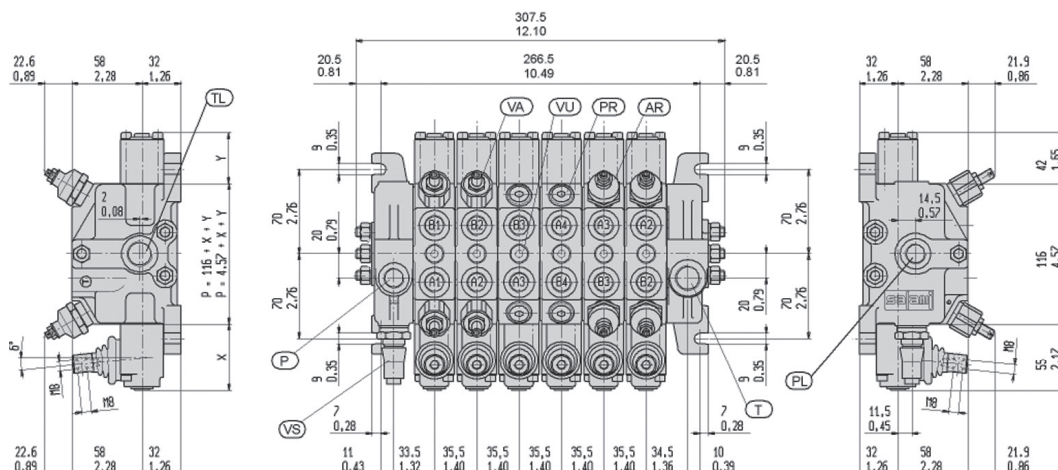

VD8A MANUAL VALVES

- VERY GOOD METERING
- MINIMAL TOLERANCE BETWEEN PARTS FOR MINIMUM INTERNAL LEAKAGE
- PARALLEL CIRCUIT (SERIE AND TANDEM SECTIONS AVAILABLE)
- LOAD CHECK ON EACH SECTION
- SEVERAL TYPE OF SPOOLS AND CONTROLS
- POSSIBLY TO ADD PORT RELIEF WITH OR WITHOUT ANTI-CAVITATION
- ELECTRO-HYDRAULIC CONTROL AVAILABLE
- HANDLES INCLUDED
- WE CAN ASSEMBLE AND CUSTOMIZE FOR YOU

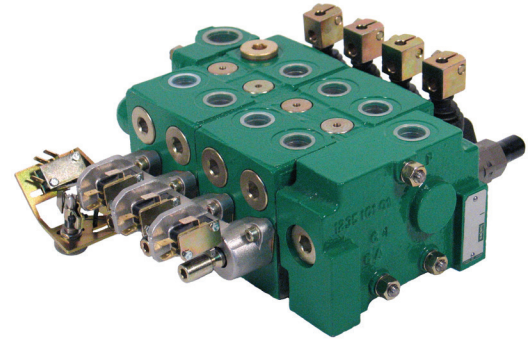

MODEL CODE	SECTIONS	MAX GPM	MAX PSI	PORT SIZE
VD8A	1 - 8	24	5000	P, A & B: SAE-10 T: SAE-12

COMPONENTS

MODEL CODE	TYPE	DESCRIPTION
R23570410	INLET	RELIEF SET TO 2750 PSI
S23580290	SECTION	DOUBLE ACTING, SPRING RETURN, LEVER
S23582951		MOTOR, SPRING RETURN, LEVER
S23581911		SINGLE ACTING PORT A, SPRING RETURN, LEVER
S23582600		4TH POSITION FLOAT, SPRING RETURN, LEVER
S23572720		DOUBLE ACTING, 12V, EMERGENCY LEVER (18.5 GPM MAX)
S23582390		SERIE, DOUBLE ACTING, SPRING RETURN, NO LEVER
S23582800		TANDEM, DOUBLE ACTING, SPRING RETURN, LEVER
R23580030		OUTLET
R23585010	ASSY KIT	1 SECTION
R23585020		2 SECTIONS
R23585030		3 SECTIONS
R23585040		4 SECTIONS
R23585050		5 SECTIONS
R23585060		6 SECTIONS
R23585070		7 SECTIONS
R23585080		8 SECTIONS

PARTS

MODEL CODE	DESCRIPTION
795429200	POWER BEYOND SLEEVE OR CLOSED CENTER
R23500300	DETENT KIT IN & OUT R2
R23500400	DETENT KIT OUT R4
R23500500	DETENT KIT IN R5
R23587570	JOYSTICK KIT
R20289960	JOYSTICK HANDLE
R360T0200	CABLE ADAPTOR KIT
R23575390	PNEUMATIC CONTROL KIT
796366200	PORT RELIEF 220 - 1015 PSI
796370801	PORT RELIEF 1030 - 2175 PSI
796366400	PORT RELIEF 2200 - 3115 PSI
796366700	PORT RELIEF + ANTI-CAVITATION 1450 - 5000 PSI
R20287910	LEVER BOX
420290180	HANDLE
R23575070	SPRING RETURN
R20272590	SPOOL SEAL KIT
R23572500	SIDE SEAL KIT

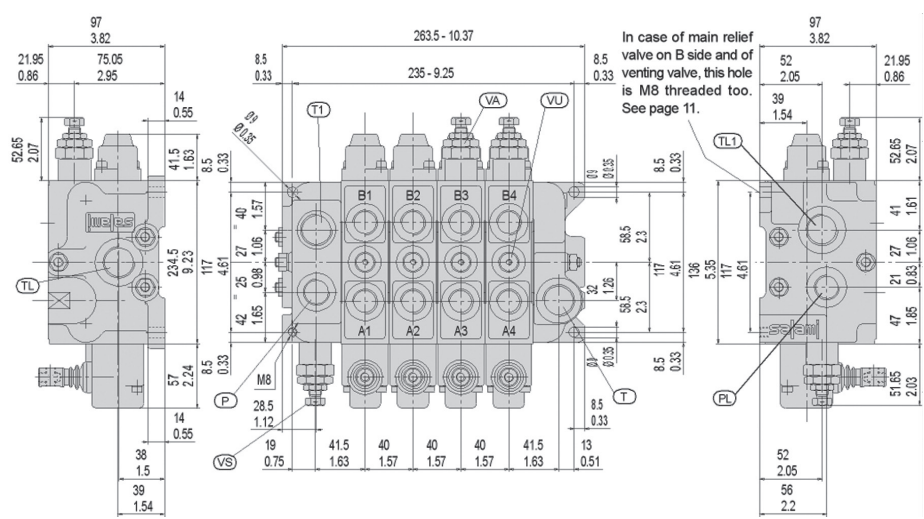

VD10A VALVES

- VERY GOOD METERING
- MINIMAL TOLERANCE BETWEEN PARTS FOR MINIMUM INTERNAL LEAKAGE
- PARALLEL CIRCUIT (SERIE AND TANDEM SECTIONS AVAILABLE)
- LOAD CHECK ON EACH SECTION
- SEVERAL TYPE OF SPOOLS AND CONTROLS
- POSSIBLY TO ADD PORT RELIEF WITH OR WITHOUT ANTI-CAVITATION
- HANDLES INCLUDED
- WE CAN ASSEMBLE AND CUSTOMIZE FOR YOU

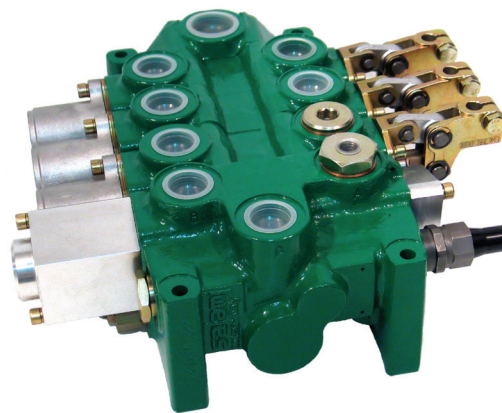

MODEL CODE	SECTIONS	MAX GPM	MAX PSI	PORT SIZE
VD10A	1 - 8	37	4000	P, A & B: SAE-12 T: SAE-16

COMPONENTS

MODEL CODE	TYPE	DESCRIPTION
S22081401	INLET + SECTION	RELIEF SET TO 2750 PSI
S22081391	SECTION	DOUBLE ACTING, SPRING RETURN, LEVER
S22081501		MOTOR, SPRING RETURN, LEVER
S22081531		4TH POSITION FLOAT, SPRING RETURN, LEVER
R22090050	OUTLET	OPEN CENTER
R22085110	ASSY KIT	1 SECTION
R22085120		2 SECTIONS
R22085130		3 SECTIONS
R22085140		4 SECTIONS
R22085150		5 SECTIONS
R22085160		6 SECTIONS
R22085170		7 SECTIONS
R22085180		8 SECTIONS

PARTS

MODEL CODE	DESCRIPTION
R22080130	POWER BEYOND SLEEVE OR CLOSED CENTER
R22400309	DETENT KIT IN & OUT R2
R22400409	DETENT KIT OUT R4
R22400509	DETENT KIT IN R5
R360T0500	CABLE ADAPTOR KIT
R22176331	PNEUMATIC CONTROL KIT
R22078410	PORT RELIEF 725 - 1525 PSI
R22078420	PORT RELIEF 1525 - 3045 PSI
R22470080	PORT RELIEF + ANTI-CAVITATION 725 - 4060 PSI
R22187570	LEVER BOX
422187690	HANDLE
R22100200	SPRING RETURN
R22472519	SPOOL SEAL KIT
R22072500	SIDE SEAL KIT

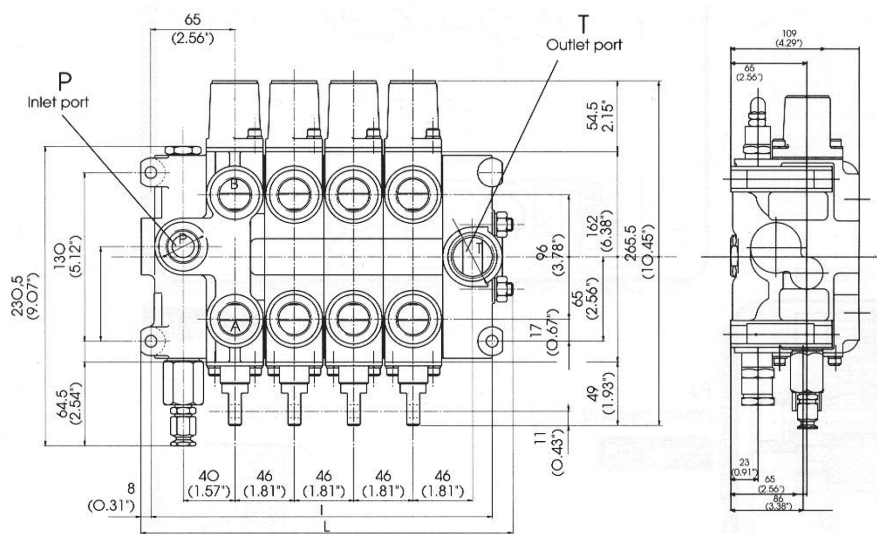

VD12A VALVES

- VERY GOOD METERING
- MINIMAL TOLERANCE BETWEEN PARTS FOR MINIMUM INTERNAL LEAKAGE
- PARALLEL CIRCUIT (SERIE AND TANDEM SECTIONS AVAILABLE)
- LOAD CHECK ON EACH SECTION
- SEVERAL TYPE OF SPOOLS AND CONTROLS
- POSSIBLY TO ADD PORT RELIEF WITH OR WITHOUT ANTI-CAVITATION
- HANDLES INCLUDED

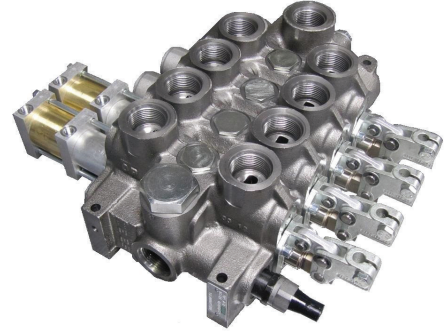

MODEL CODE	SECTIONS	MAX GPM	MAX PSI	PORT SIZE
VD12A	1 - 8	63	4000	P, A & B: SAE-12 T: SAE-16

COMPONENTS

MODEL CODE	TYPE	DESCRIPTION
S22480420	INLET + SECTION	RELIEF SET TO 2750 PSI
S22480410	SECTION	DOUBLE ACTING, SPRING RETURN, LEVER
S22480660		MOTOR, SPRING RETURN, LEVER
S22480470		4TH POSITION FLOAT, SPRING RETURN, LEVER
R22490029		OUTLET
R22490080	OUTLET	OPEN CENTER, SAE-20
R22485019	ASSY KIT	1 SECTION
R22485029		2 SECTIONS
R22485039		3 SECTIONS
R22485049		4 SECTIONS
R22485059		5 SECTIONS
R22485069		6 SECTIONS
R22485079		7 SECTIONS
R22485089		8 SECTIONS

PARTS

MODEL CODE	DESCRIPTION
795429500	POWER BEYOND PLUG OR CLOSED CENTER
R22400309	DETENT KIT IN & OUT R2
R22400409	DETENT KIT OUT R4
R22400509	DETENT KIT IN R5
R360T0500	CABLE ADAPTOR KIT
R22176331	PNEUMATIC CONTROL KIT
R22078410	PORT RELIEF 725 - 1525 PSI
R22078420	PORT RELIEF 1525 - 3045 PSI
R22470080	PORT RELIEF + ANTI-CAVITATION 725 - 4060 PSI
R22187570	LEVER BOX
422187690	HANDLE
R22100200	SPRING RETURN
R22472519	SPOOL SEAL KIT
R22472529	SIDE SEAL KIT

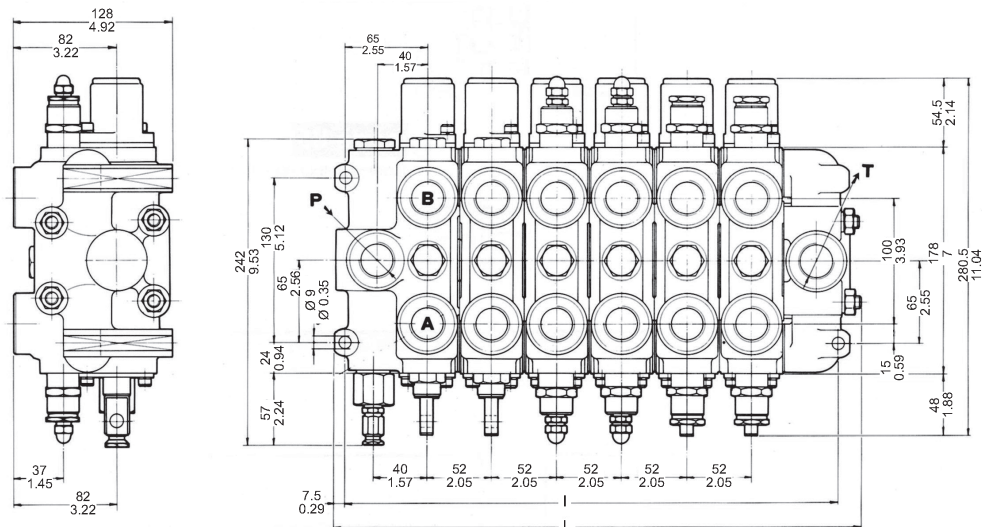

SN-3

NOMINAL FLOW RATE	13 GPM
OPERATING PRESSURE (MAXIMUM) PARALLE CIRCUIT	4600 PSI
BACK PRESSURE (MAXIMUM) ON OUTLET PORT T	360 PSI



SN-4

NOMINAL FLOW RATE	21 GPM
OPERATING PRESSURE (MAXIMUM) PARALLE CIRCUIT	4600 PSI
BACK PRESSURE (MAXIMUM) ON OUTLET PORT T	360 PSI



SN-5

NOMINAL FLOW RATE	32 GPM
OPERATING PRESSURE (MAXIMUM) PARALLE CIRCUIT	4600 PSI
BACK PRESSURE (MAXIMUM) ON OUTLET PORT T	360 PSI



SN-6

NOMINAL FLOW RATE	42 GPM
OPERATING PRESSURE (MAXIMUM) PARALLE CIRCUIT	4600 PSI
BACK PRESSURE (MAXIMUM) ON OUTLET PORT T	360 PSI



SN-8

NOMINAL FLOW RATE	63 GPM
OPERATING PRESSURE (MAXIMUM) PARALLE CIRCUIT	4600 PSI
BACK PRESSURE (MAXIMUM) ON OUTLET PORT T	360 PSI



PV4 VALVES

- LOAD SENSING PROPORTIONAL FOR FIXED AND VARIABLE DISPLACEMENT PUMPS
- FOR MOBILE & INDUSTRIAL APPLICATION
- FULLY CUSTOMIZED VALVE
- CHOICE OF SPOOLS ESPECIALLY DESIGNED FOR REQUEST FLOW
- LEVERS WITH INDIVIDUAL FLOW ADJUSTMENT SCREWS
- MANY CONTROLS AVAILABLE SUCH AS:
 - SINGLE MANUAL LEVERS
 - ELECTRONIC ON/OFF SIGNAL
 - PROPORTIONNAL ANALOG OR PWM SIGNAL
 - HYDRAULIC & CABLE CONTROLS
 - FRICTION DETENT
- SHOCK AND ANTI-CAVITATION VALVES AVAILABLE
- GREAT CHOICE OF DIFFERENT INLETS

FITS "PVG32"
DANFOSS FOOTPRINT



PV3 VALVES

- SAME AS PV4 VALVES. MORE COMPACT SECTIONS
- FITS "PVG16" DANFOSS FOOTPRINT

MODELS	MAX GPM	MAX PSI	PORT SIZE		
			P	T	A & B
PV3 OR PV4	37	5075	SAE-08 SAE-10	SAE-12	SAE-10

PVH-1 PROPORTIONAL CONTROL

- SINGLE LEVER FOR ONE SECTION OPERATION
- ESPECIALLY DESIGNED TO BE INSTALLED WITH PV4 & PV3 VALVES

INPUT RANGE	11-30VDC
CURRENT CONSUMPTION	100 mA
OUTPUT VOLTAGE	0.25 - 0.75 VDC
NEUTRAL VOLTAGE	0.5 VDC

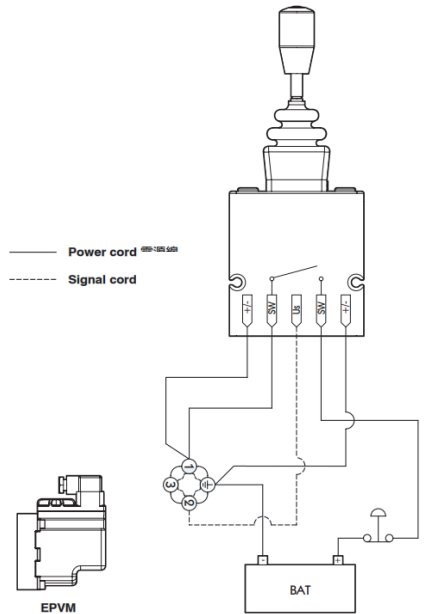
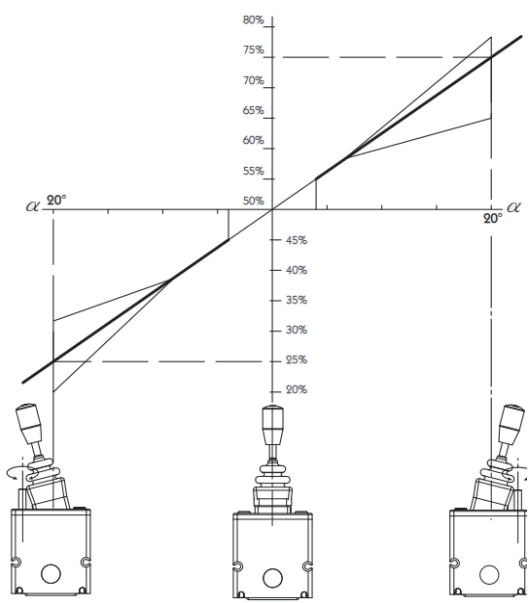

PDV VALVES

PDV VALVES ARE NEW BREAKTHROUGH PRODUCTS WITH UPGRADED HYDRAULIC FUNCTIONS THAT FULFILL THE EVER INCREASING MARKET DEMANDS FOR IMPROVED MACHINES PRODUCTIVITY, SAFETY, REQUIREMENTS, ENERGY EFFICIENT AND ENVIRONMENTAL OPERATION.

BASED ON LOAD SENSING TECHNOLOGY, THE ABILITY TO METER IN OUT ANY LOAD ACTUATORS PROVIDES A WIDE CHOICE OF CONTROL OPTIONS, AND ARE MEANT TO BE USED IN HAZARDOUS AREA.

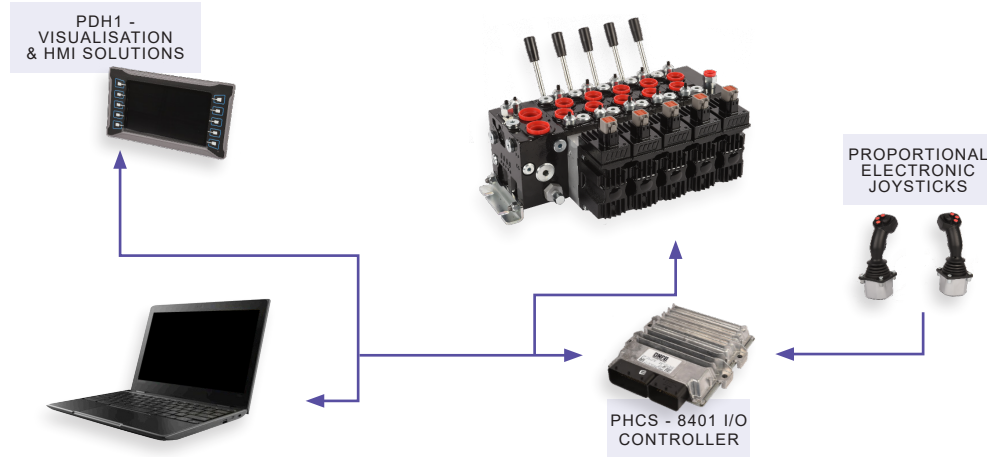

- ELECTROHYDRAULIC CONTROL
- HYDRAULIC CONTROL
- MANUAL CONTROL
- UP-STREAM PRESSURE COMPENSATED
- LOAD INDEPENDENT FLOW
- CAN BE OPERATES WITH BOTH FIXED AND VARIABLE DISPLACEMENT PUMPS
- HIGH POWER CAPABILITY CONTROL IN COMPACT DIMENSION
- HIGH REPEATABILITY FLOW ACCURACY
- FLEXIBLE HIGH-QUALITY PRODUCT

MODELS	MAX GPM P PORT	MAX GPM A&B PORTS	MAX PSI	PORT SIZE		
				P	T	A&B
PDV 74	42	34	5370	SAE-12	SAE-12	SAE-10
PDV 114	69	50		SAE-16	SAE-16	SAE-12
PDV 315	158	132		1 1/4" CODE FLANGE 62 (MM)	1 1/2" CODE FLANGE 61 (MM)	1 1/4" CODE FLANGE 62 (MM)

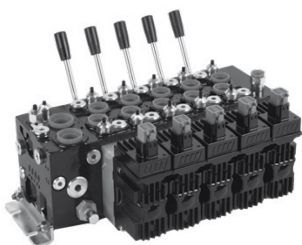

PDV 74

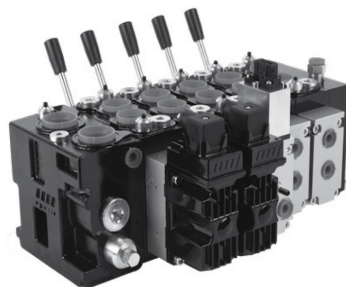

PDV 114

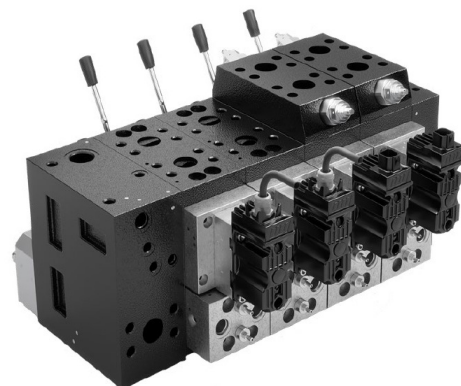

PDV 315

WIRELESS TRANSMITTER AND RECEIVER

Remote control solutions for industries where safety and reliability are crucial. the operator can stand on the side and control the machine from a safe distance. Ideal for :

- large construction cranes
- drilling rigs
- concrete pumps
- forestry machines
- truck cranes



BAILEY BLUETOOTH® CONTROLLER

The Bailey Bluetooth® Controller is a Bluetooth® receiver with four outputs. Using the Bailey App on your smartphone, electrical loads can be switched on and off. The Bailey app allows the user to visualize the respective outputs as well as their status (on / off) and create unique configurations for each functions application. Application examples include: hydraulic power unit control, winches, dump trailers, lift tables, roll-back trucks, jacks, electric motor, lights, and more.

Features:

- 9-36Vdc, 10 amps, 3.7 amps per channel
- 4-function configurable control outputs
- Operating range up to 246 ft.
- -40° to 176° F temperature range
- Molded casing (IP66)
- Easy install with plug and play wiring harness and setup guide
- Customized icons for a variety of applications
- Momentary, maintained, timed, and lock-out control options
- Settings are stored on receiver and can be password protected
- Retail packaged and user manual included



BAILEY PART NO 301300

APPLICATION ICONS

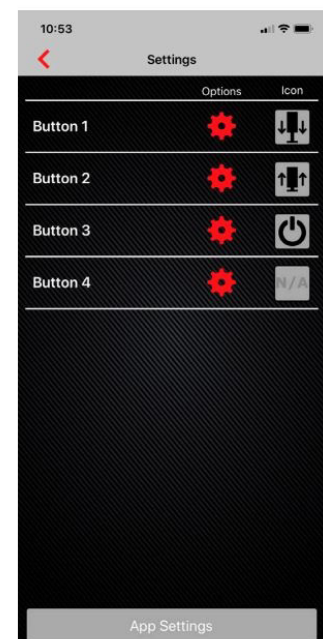
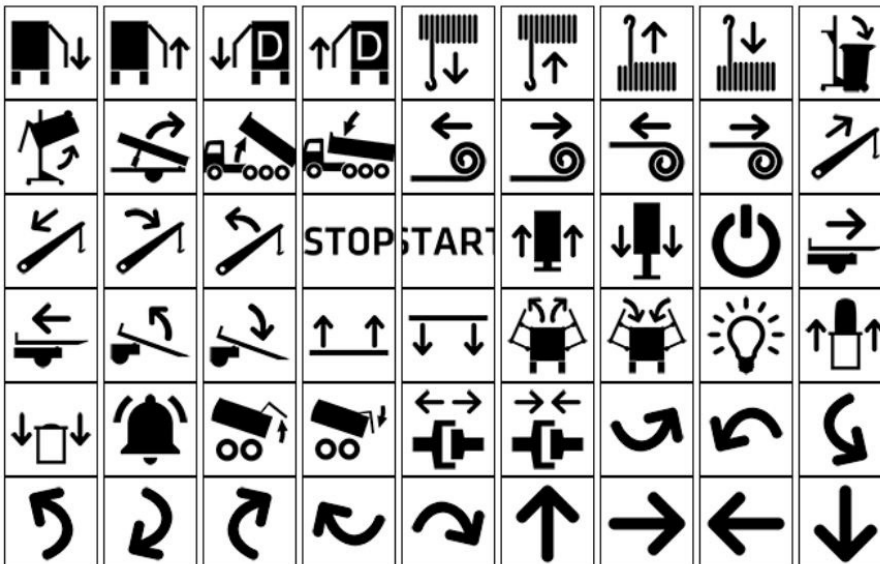

Air proportional cab switch with full integrated lever to control both PTO engagement and tipping/lowering. Several versions available to meet any requirements.

N-FORCE PNEUMATIC CONTROLS

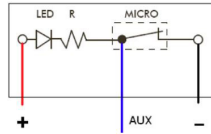
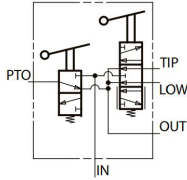

MODEL CODE	DESCRIPTION
100 001 81003	AUTOMATIC PTO KNOCK-OFF, 1/4" AIR FITTINGS
100 001 81030	MANUAL PTO KNOCK-OFF, 1/4" AIR FITTINGS

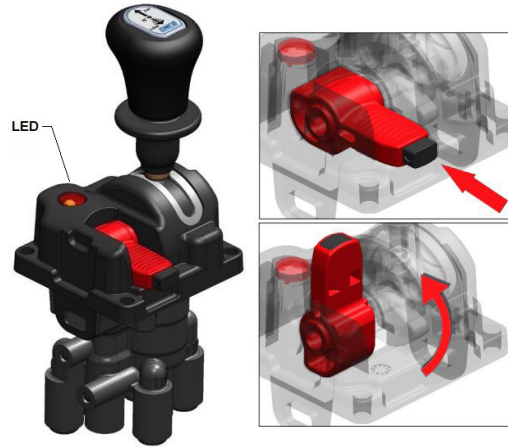

N-GAGE AIR CAB SWITCH

MODEL CODE	DESCRIPTION
100 001 81003	3/2, DETENT, LED, 1/4" AIR FITTINGS



3 POSITION PNEUMATIC CONTROLS

MODEL CODE	DESCRIPTION
100 001 42015	DETENT ON NEUTRAL POSITION. PROPORTIONNAL LOWERING TIPPING

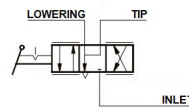

ALSO AVAILABLE ON REQUEST



SINGLE AND DUAL ROTARY PNEUMATIC SWITCHES



PUSH PULL PNEUMATIC SWITCHES

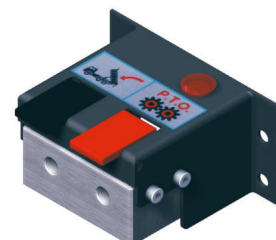

DUAL AND TRIPLE PNEUMATIC SWITCHES

FITS ON HYDRAULIC VALVES

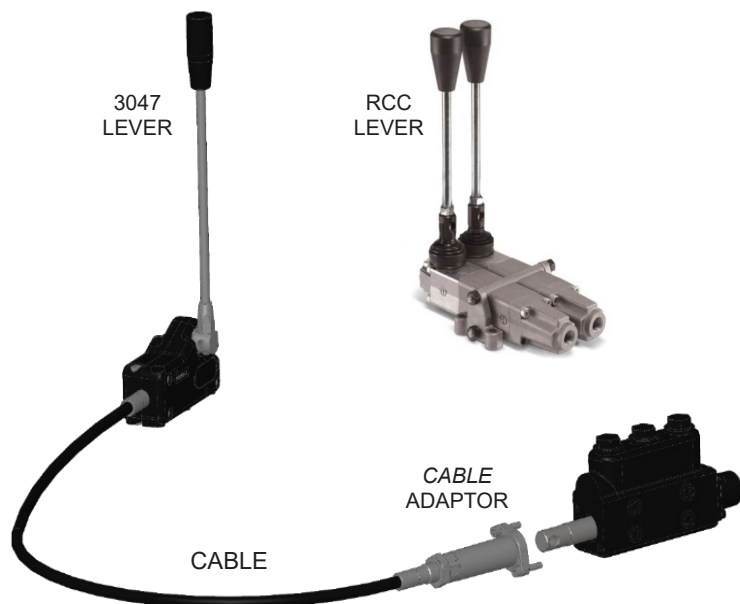

LEVER AND JOYSTICK

MODEL CODE	DESCRIPTION	BRAND
3047	SINGLE AXIS	SALAMI, PRINCE
3336	DUAL AXIS	
RCC3-1S-HL+GC	SINGLE AXIS FOR MB2, MB3, MB4	YOULI, WALVOIL
RCC5-1S-HL+GC	SINGLE AXIS FOR MB5	
FCR-2	DUAL AXIS JOYSTICK	

CABLE ADAPTORS FOR VALVES

MODEL CODE	VALVE MODELS	BRAND
R360T0200	VDM8, VD8A, VDM7	SALAMI
R360T0400	VDM9	
R360T0500	VD10A & VD12A	
R360T0600	VDM6, VD6A, VDM6A	
660170035	V20	PRINCE
660170037	RD500	
YLMB45003	MB2, MB3, MB4 & SD4, SD5	YOULI, WALVOIL
YLMB55003	MB5 & SD11	



CABLES

MODEL CODE	LENGHT	BRAND
IT-731133/01.00	39.4 IN (1 M)	SALAMI, PRINCE
IT-731133/01.50	59.1 IN (1.5 M)	
IT-731133/02.00	78.7 IN (2 M)	
IT-731133/02.50	98.4 IN (2.5 M)	
IT-731133/03.00	118.1 IN (3 M)	
IT-731133/03.50	137.8 IN (3.5 M)	
IT-731133/04.00	157.5 IN (4 M)	
CABLE-1000	39.4 IN (1 M)	
CABLE-1500	59.1 IN (1.5 M)	
CABLE-2000	78.7 IN (2 M)	



MORSE TYPE LEVERS

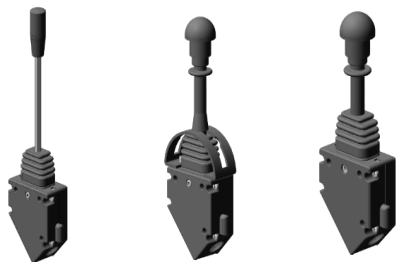

LEVERS

MODEL CODE	DESCRIPTION	TRAVEL
3430	SPRING RETURN	32 MM
3488	WITH DETENT	
3461	WITH CENTRAL LOCK KNOB	

CABLES

MODEL CODE	LENGHT	FIT
732491/01.00	39.4 IN (1 M)	MORSE TYPE LEVERS
732491/02.00	78.7 IN (2 M)	
732491/03.00	118.1 IN (3 M)	

LONG STROKE LEVERS

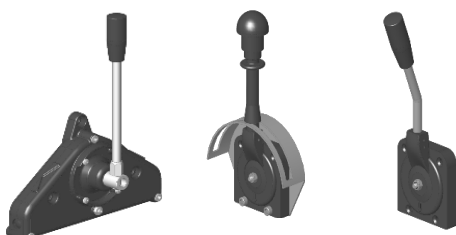

LEVERS

MODEL CODE	DESCRIPTION	TRAVEL
3472	RACK GEAR	75 MM
3401	HAND THROTTLE	80 MM
3408	HAND THROTTLE WITH LEVER	

CABLES

MODEL CODE	LENGHT	FIT
741715/01.50	59.1 IN (1.5 M)	RACK GEARS
741715/02.00	78.7 IN (2 M)	
741715/03.00	118.1 IN (3 M)	
732882/01.00	39.4 IN (1 M)	HAND THROTTLE
732882/02.00	78.7 IN (2 M)	
732882/03.00	118.1 IN (3 M)	

PEDAL THROTTLES

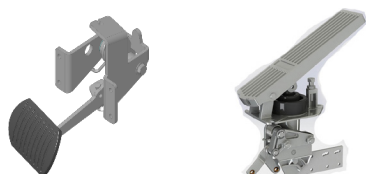

THROTTLES

MODEL CODE	DESCRIPTION	TRAVEL
4021	BULKHEAD MOUNT WITH DETENT	28 MM
208991	FLOOR MOUNT, WITH LEVER	

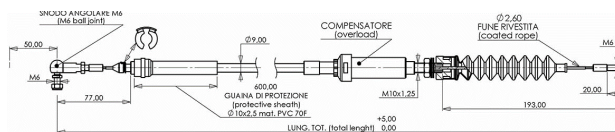

CABLES

MODEL CODE	LENGHT	FIT
732491/01.00	39.4 IN (1 M)	BULKHEAD MOUNT PEDAL
732491/02.00	78.7 IN (2 M)	
732491/03.00	118.1 IN (3 M)	

ROCKER PEDALS

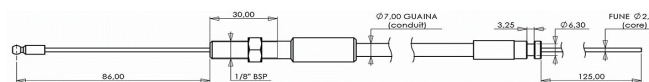

PEDALS

MODEL CODE	DESCRIPTION	TRAVEL
631368	SINGLE ROCKER PEDAL	17 MM
631366	DOUBLE ROCKER PEDALS	14 MM

CABLES

MODEL CODE	LENGHT	FIT
731921/01.00	39.4 IN (1 M)	ROCKER PEDAL
731921/02.00	78.7 IN (2 M)	
731921/03.00	118.1 IN (3 M)	

CETOP D03 VALVES

- INTERCHANGEABLE WITH CETOP AND ISO VALVES ON THE MARKET
- DIN CONNECTORS WITH LED INCLUDED
- BOLT KIT INCLUDED (HYDRO-CUSTOM VALVES ONLY)
- UL AND CE PROOF. CSA ON DEMAND
- OTHER SPOOL MODELS AND VOLTAGE AVAILAIBLE
- SOFTSHIFT VALVES AVAILABLE







DIN CONN

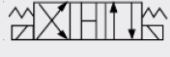

TERMINAL BOX

MAXIMUM PRESSURE: 4560 PSI
 MAXIMUM BACK PRESSURE: 2320 PSI
 WEIGHT: 4.0 LBS (3.0 LBS FOR 2 POSITION MODELS)

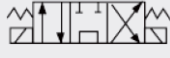
HYDRO CUSTOM MODEL CODE	VOLTAGE	MAX GPM @3600 PSI	SPOOL MODEL	MAX GPM @3600 PSI	VOLTAGE	YUKEN PART NO
4WE6-D-6X/ED12-LL	12 VDC DIN	18		21	12 VDC DIN	DSG01-2B2-D12N
4WE6-D-6X/ED12-BL	12 VDC BOX				12 VDC BOX	DSG01-2B2-D12
4WE6-D-6X/ED24-LL	24 VDC DIN				24 VDC DIN	DSG01-2B2-D24N
4WE6-D-6X/ED24-BL	24 VDC BOX				24 VDC BOX	DSG01-2B2-D24
4WE6-D-6X/ER110-LL	110 VAC DIN				110 VAC DIN	DSG01-2B2-A120N
4WE6-D-6X/ER110-BL	110 VAC BOX				110 VAC BOX	DSG01-2B2-A120
4WE6-E-6X/ED12-LL	12 VDC DIN	21		26	12 VDC DIN	DSG01-3C2-D12N
4WE6-E-6X/ED12-BL	12 VDC BOX				12 VDC BOX	DSG01-3C2-D12
4WE6-E-6X/ED24-LL	24 VDC DIN				24 VDC DIN	DSG01-3C2-D24N
4WE6-E-6X/ED24-BL	24 VDC BOX				24 VDC BOX	DSG01-3C2-D24
4WE6-E-6X/ER110-LL	110 VAC DIN				110 VAC DIN	DSG01-3C2-A120N
4WE6-E-6X/ER110-BL	110 VAC BOX				110 VAC BOX	DSG01-3C2-A120
4WE6-H-6X/ED12-LL	12 VDC DIN	13		24	12 VDC DIN	DSG01-3C3-D12N
4WE6-H-6X/ED12-BL	12 VDC BOX				12 VDC BOX	DSG01-3C3-D12
4WE6-H-6X/ED24-LL	24 VDC DIN				24 VDC DIN	DSG01-3C3-D24N
4WE6-H-6X/ED24-BL	24 VDC BOX				24 VDC BOX	DSG01-3C3-D24
4WE6-H-6X/ER110-LL	110 VAC DIN				110 VAC DIN	DSG01-3C3-A120N
4WE6-H-6X/ER110-BL	110 VAC BOX				110 VAC BOX	DSG01-3C3-A120
4WE6-J-6X/ED12-LL	12 VDC DIN	21		24	12 VDC DIN	DSG01-3C4-D12N
4WE6-J-6X/ED12-BL	12 VDC BOX				12 VDC BOX	DSG01-3C4-D12
4WE6-J-6X/ED24-LL	24 VDC DIN				24 VDC DIN	DSG01-3C4-D24N
4WE6-J-6X/ED24-BL	24 VDC BOX				24 VDC BOX	DSG01-3C4-D24
4WE6-J-6X/ER110-LL	110 VAC DIN				110 VAC DIN	DSG01-3C4-A120N
4WE6-J-6X/ER110-BL	110 VAC BOX				110 VAC BOX	DSG01-3C4-A120
4WE6-G-6X/ED12-LL	12 VDC DIN	13		10	12 VDC DIN	DSG01-3C60-D12N
4WE6-G-6X/ED12-BL	12 VDC BOX				12 VDC BOX	DSG01-3C60-D12
4WE6-G-6X/ED24-LL	24 VDC DIN				24 VDC DIN	DSG01-3C60-D24N
4WE6-G-6X/ED24-BL	24 VDC BOX				24 VDC BOX	DSG01-3C60-D24
4WE6-G-6X/ER110-LL	110 VAC DIN				110 VAC DIN	DSG01-3C60-A120N
4WE6-G-6X/ER110-BL	110 VAC BOX				110 VAC BOX	DSG01-3C60-A120

YUKEN VALVES: BOLT KIT MUST BE ORDERED SEPARATELY

BOLT KIT

MODEL CODE	DESCRIPTION
MBK01-175	INCLUDED WITH HYDRO-CUSTOM VALVES NOT INCLUDED WITH YUKEN VALVES. MUST BE ORDERED SEPARATELY



SUBPLATES

MODEL CODE	DESCRIPTION	WEIGHT (LBS)
SPA03-SB-S08	ALU, 3000 PSI, ALL PORTS ON SIDE. P & T ALSO ON BOTTOM	1.5
SPA03-SB-S08-C10-2	SAME AS SPA03-SB-S08 PLUS C10-2 RELIEF CAVITY	2.5



CETOP D05 VALVES

- * INTERCHANGEABLE WITH CETOP AND ISO VALVES ON THE MARKET
- * DIN CONNECTORS WITH LED INCLUDED
- * BOLT KIT INCLUDED (HYDRO-CUSTOM VALVES ONLY)
- * UL AND CE PROOF. CSA ON DEMAND
- * OTHER SPOOL MODELS AND VOLTAGE AVAILAILBLE
- * SOFTSHIFT VALVES AVAILABLE



DIN CONN



TERMINAL BOX

MAXIMUM PRESSURE: 4560 PSI
 MAXIMUM BACK PRESSURE: 2320 PSI
 WEIGHT: 7.9 LBS (6.4 LBS FOR THE 2 POSITION MODELS)

HYDRO CUSTOM MODEL CODE	VOLTAGE	MAX GPM @3600 PSI	SPOOL MODEL	MAX GPM @3600 PSI	VOLTAGE	YUKEN PART NO
4WE10-D-3X/CD12-LL	12 VDC DIN	26		32	12 VDC DIN	DSG03-2B2-D12N
4WE10-D-3X/CD12-BL	12 VDC BOX				12 VDC BOX	DSG03-2B2-D12
4WE10-D-3X/CD24-LL	24 VDC DIN				24 VDC DIN	DSG03-2B2-D24N
4WE10-D-3X/CD24-BL	24 VDC BOX				24 VDC BOX	DSG03-2B2-D24
4WE10-D-3X/CR110-LL	110 VAC DIN				110 VAC DIN	DSG03-2B2-A120N
4WE10-D-3X/CR110-BL	110 VAC BOX				110 VAC BOX	DSG03-2B2-A120
4WE10-E-3X/CD12-LL	12 VDC DIN	32		26	12 VDC DIN	DSG03-3C2-D12N
4WE10-E-3X/CD12-BL	12 VDC BOX				12 VDC BOX	DSG03-3C2-D12
4WE10-E-3X/CD24-LL	24 VDC DIN				24 VDC DIN	DSG03-3C2-D24N
4WE10-E-3X/CD24-BL	24 VDC BOX				24 VDC BOX	DSG03-3C2-D24
4WE10-E-3X/CR110-LL	110 VAC DIN				110 VAC DIN	DSG03-3C2-A120N
4WE10-E-3X/CR110-BL	110 VAC BOX				110 VAC BOX	DSG03-3C2-A120
4WE10-H-3X/CD12-LL	12 VDC DIN	26		24	12 VDC DIN	DSG03-3C3-D12N
4WE10-H-3X/CD12-BL	12 VDC BOX				12 VDC BOX	DSG03-3C3-D12
4WE10-H-3X/CD24-LL	24 VDC DIN				24 VDC DIN	DSG03-3C3-D24N
4WE10-H-3X/CD24-BL	24 VDC BOX				24 VDC BOX	DSG03-3C3-D24
4WE10-H-3X/CR110-LL	110 VAC DIN				110 VAC DIN	DSG03-3C3-A120N
4WE10-H-3X/CR110-BL	110 VAC BOX				110 VAC BOX	DSG03-3C3-A120
4WE10-J-3X/CD12-LL	12 VDC DIN	32		24	12 VDC DIN	DSG03-3C4-D12N
4WE10-J-3X/CD12-BL	12 VDC BOX				12 VDC BOX	DSG03-3C4-D12
4WE10-J-3X/CD24-LL	24 VDC DIN				24 VDC DIN	DSG03-3C4-D24N
4WE10-J-3X/CD24-BL	24 VDC BOX				24 VDC BOX	DSG03-3C4-D24
4WE10-J-3X/CR110-LL	110 VAC DIN				110 VAC DIN	DSG03-3C4-A120N
4WE10-J-3X/CR110-BL	110 VAC BOX				110 VAC BOX	DSG03-3C4-A120
4WE10-G-3X/CD12-LL	12 VDC DIN	21		18	12 VDC DIN	DSG03-3C60-D12N
4WE10-G-3X/CD12-BL	12 VDC BOX				12 VDC BOX	DSG03-3C60-D12
4WE10-G-3X/CD24-LL	24 VDC DIN				24 VDC DIN	DSG03-3C60-D24N
4WE10-G-3X/CD24-BL	24 VDC BOX				24 VDC BOX	DSG03-3C60-D24
4WE10-G-3X/CR110-LL	110 VAC DIN				110 VAC DIN	DSG03-3C60-A120N
4WE10-G-3X/CR110-BL	110 VAC BOX				110 VAC BOX	DSG03-3C60-A120

YUKEN VALVES: BOLT KIT MUST BE ORDERED SEPARATELY

BOLT KIT

MODEL CODE	DESCRIPTION
MBK03-150	INCLUDED WITH HYDRO-CUSTOM VALVES NOT INCLUDED WITH YUKEN VALVES. MUST BE ORDERED SEPARATELY



SUBPLATES

MODEL CODE	DESCRIPTION	WEIGHT (LBS)
SPA05-SP-S10	ALU, 3000 PSI, SAE-10, SIDE PORTS	3.3
SPA05-SB-S10-C10-2	ALU, 3000 PSI, SIDE PORTS. P & T ALSO ON BOTTOM, SAE-10 C10-2 RELIEF CAVITY	3.3





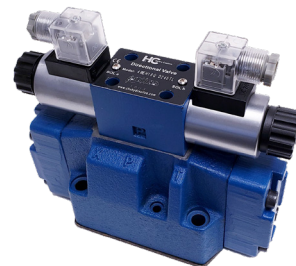

CETOP D07 VALVES

- INTERCHANGEABLE WITH CETOP AND ISO VALVES ON THE MARKET
- DIN CONNECTORS WITH LED INCLUDED
- UL AND CE PROOF. CSA ON DEMAND
- OTHER SPOOL MODELS AND VOLTAGE AVAILAILBLE
- INTERNAL PILOT, EXTERNAL DRAIN SETUP. EASY TO MODIFY

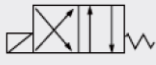

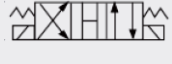
MAXIMUM PRESSURE: 4560 PSI
 MAXIMUM BACK PRESSURE: 2320 PSI
 WEIGHT: 18.7 LBS (17.6 LBS FOR 2 POSITION MODELS)

HYDRO CUSTOM MODEL CODE	VOLTAGE	MAX GPM @3600 PSI	SPOOL MODEL	MAX GPM @3600 PSI	VOLTAGE	YUKEN MODEL CODE
4WEH16-D-D12-E-LL	12 VDC DIN	66		79	12 VDC DIN	DSHG04-2B2-D12N
4WEH16-D-D12-E-BL	12 VDC BOX				12 VDC BOX	DSHG04-2B2-D12
4WEH16-D-D24-E-LL	24 VDC DIN				24 VDC DIN	DSHG04-2B2-D24N
4WEH16-D-D24-E-BL	24 VDC BOX				24 VDC BOX	DSHG04-2B2-D24
4WEH16-D-R110-E-LL	110 VAC DIN				110 VAC DIN	DSHG04-2B2-A120N
4WEH16-D-R110-E-BL	110 VAC BOX				110 VAC BOX	DSHG04-2B2-A120
4WEH16-E-D12-E-LL	12 VDC DIN	66		53	12 VDC DIN	DSHG04-3C2-D12N
4WEH16-E-D12-E-BL	12 VDC BOX				12 VDC BOX	DSHG04-3C2-D12
4WEH16-E-D24-E-LL	24 VDC DIN				24 VDC DIN	DSHG04-3C2-D24N
4WEH16-E-D24-E-BL	24 VDC BOX				24 VDC BOX	DSHG04-3C2-D24
4WEH16-E-R110-E-LL	110 VAC DIN				110 VAC DIN	DSHG04-3C2-A120N
4WEH16-E-R110-E-BL	110 VAC BOX				110 VAC BOX	DSHG04-3C2-A120
4WEH16-H-D12-E-LL*	12 VDC DIN	79		79	12 VDC DIN	DSHG04-3C3-D12N
4WEH16-H-D12-E-BL*	12 VDC BOX				12 VDC BOX	DSHG04-3C3-D12
4WEH16-H-D24-E-LL*	24 VDC DIN				24 VDC DIN	DSHG04-3C3-D24N
4WEH16-H-D24-E-BL*	24 VDC BOX				24 VDC BOX	DSHG04-3C3-D24
4WEH16-H-R110-E-LL*	110 VAC DIN				110 VAC DIN	DSHG04-3C3-A120N
4WEH16-H-R110-E-BL*	110 VAC BOX				110 VAC BOX	DSHG04-3C3-A120
4WEH16-J-D12-E-LL	12 VDC DIN	79		66	12 VDC DIN	DSHG04-3C4-D12N
4WEH16-J-D12-E-BL	12 VDC BOX				12 VDC BOX	DSHG04-3C4-D12
4WEH16-J-D24-E-LL	24 VDC DIN				24 VDC DIN	DSHG04-3C4-D24N
4WEH16-J-D24-E-BL	24 VDC BOX				24 VDC BOX	DSHG04-3C4-D24
4WEH16-J-R110-E-LL	110 VAC DIN				110 VAC DIN	DSHG04-3C4-A120N
4WEH16-J-R110-E-BL	110 VAC BOX				110 VAC BOX	DSHG04-3C4-A120
4WEH16-G-D12-E-LL*	12 VDC DIN	66		79	12 VDC DIN	DSHG04-3C60-D12N
4WEH16-G-D12-E-BL*	12 VDC BOX				12 VDC BOX	DSHG04-3C60-D12
4WEH16-G-D24-E-LL*	24 VDC DIN				24 VDC DIN	DSHG04-3C60-D24N
4WEH16-G-D24-E-BL*	24 VDC BOX				24 VDC BOX	DSHG04-3C60-D24
4WEH16-G-R110-E-LL*	110 VAC DIN				110 VAC DIN	DSHG04-3C60-A120N
4WEH16-G-R110-E-BL*	110 VAC BOX				110 VAC BOX	DSHG04-3C60-A120

* BACK PRESSURE VALVE REQUIRED

BOLT KIT

MODEL CODE	DESCRIPTION
MBK04	BOLT KIT FOR D07 VALVES

BACKPRESSURE VALVE

MODEL CODE	DESCRIPTION
4WEH 16-BPV	INSTALL ON 4WEH16-G AND 4WEH16-G VALVES

SUBPLATES

MODEL CODE	DESCRIPTION	WEIGHT (LBS)
SPA07-SP-S16	ALU, 3000 PSI, SAE-16, SIDE PORTS	7.0

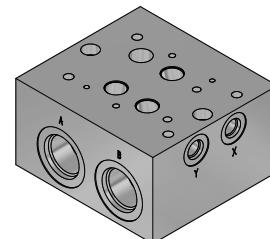

CETOP D08 VALVES

- * INTERCHANGEABLE WITH CETOP AND ISO VALVES ON THE MARKET
- * DIN CONNECTORS WITH LED INCLUDED
- * UL AND CE PROOF. CSA ON DEMAND
- * OTHER SPOOL MODELS AND VOLTAGE AVAILAILBLE
- * INTERNAL PILOT, EXTERNAL DRAIN SETUP. EASY TO MODIFY

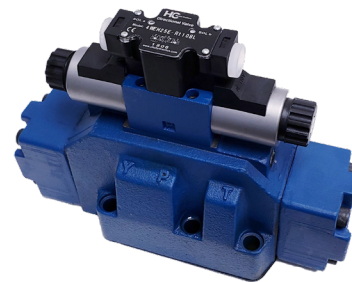

VALVES

MAXIMUM PRESSURE: 5075 PSI
 MAXIMUM BACK PRESSURE: 2320 PSI
 WEIGHT: 27.3 LBS (26.2 LBS FOR 2 POSITION MODELS)

HYDRO CUSTOM MODEL CODE	VOLTAGE	MAX GPM @3600 PSI	SPOOL MODEL	MAX GPM @3600 PSI	VOLTAGE	YUKEN MODEL CODE
4WEH25-D-D12-E-LL	12 VDC DIN	172		132	12 VDC DIN	DSHG06-2B2-D12N
4WEH25-D-D12-E-BL	12 VDC BOX				12 VDC BOX	DSHG06-2B2-D12
4WEH25-D-D24-E-LL	24 VDC DIN				24 VDC DIN	DSHG06-2B2-D24N
4WEH25-D-D24-E-BL	24 VDC BOX				24 VDC BOX	DSHG06-2B2-D24
4WEH25-D-R110-E-LL	110 VAC DIN				110 VAC DIN	DSHG06-2B2-A120N
4WEH25-D-R110-E-BL	110 VAC BOX				110 VAC BOX	DSHG06-2B2-A120
4WEH25-E-D12-E-LL	12 VDC DIN	172		132	12 VDC DIN	DSHG06-3C2-D12N
4WEH25-E-D12-E-BL	12 VDC BOX				12 VDC BOX	DSHG06-3C2-D12
4WEH25-E-D24-E-LL	24 VDC DIN				24 VDC DIN	DSHG06-3C2-D24N
4WEH25-E-D24-E-BL	24 VDC BOX				24 VDC BOX	DSHG06-3C2-D24
4WEH25-E-R110-E-LL	110 VAC DIN				110 VAC DIN	DSHG06-3C2-A120N
4WEH25-E-R110-E-BL	110 VAC BOX				110 VAC BOX	DSHG06-3C2-A120
4WEH25-H-D12-E-LL*	12 VDC DIN	172		122	12 VDC DIN	DSHG06-3C3-D12N
4WEH25-H-D12-E-BL*	12 VDC BOX				12 VDC BOX	DSHG06-3C3-D12
4WEH25-H-D24-E-LL*	24 VDC DIN				24 VDC DIN	DSHG06-3C3-D24N
4WEH25-H-D24-E-BL*	24 VDC BOX				24 VDC BOX	DSHG06-3C3-D24
4WEH25-H-R110-E-LL*	110 VAC DIN				110 VAC DIN	DSHG06-3C3-A120N
4WEH25-H-R110-E-BL*	110 VAC BOX				110 VAC BOX	DSHG06-3C3-A120
4WEH25-J-D12-E-LL	12 VDC DIN	164		132	12 VDC DIN	DSHG06-3C4-D12N
4WEH25-J-D12-E-BL	12 VDC BOX				12 VDC BOX	DSHG06-3C4-D12
4WEH25-J-D24-E-LL	24 VDC DIN				24 VDC DIN	DSHG06-3C4-D24N
4WEH25-J-D24-E-BL	24 VDC BOX				24 VDC BOX	DSHG06-3C4-D24
4WEH25-J-R110-E-LL	110 VAC DIN				110 VAC DIN	DSHG06-3C4-A120N
4WEH25-J-R110-E-BL	110 VAC BOX				110 VAC BOX	DSHG06-3C4-A120
4WEH25-G-D12-E-LL*	12 VDC DIN	172		90	12 VDC DIN	DSHG06-3C60-D12N
4WEH25-G-D12-E-BL*	12 VDC BOX				12 VDC BOX	DSHG06-3C60-D12
4WEH25-G-D24-E-LL*	24 VDC DIN				24 VDC DIN	DSHG06-3C60-D24N
4WEH25-G-D24-E-BL*	24 VDC BOX				24 VDC BOX	DSHG06-3C60-D24
4WEH25-G-R110-E-LL*	110 VAC DIN				110 VAC DIN	DSHG06-3C60-A120N
4WEH25-G-R110-E-BL*	110 VAC BOX				110 VAC BOX	DSHG06-3C60-A120

* BACK PRESSURE VALVE REQUIRED

BOLT KIT

MODEL CODE	DESCRIPTION
MBK06	BOLT KIT FOR D08 VALVES



BACKPRESSURE VALVE

MODEL CODE	DESCRIPTION
4WEH 25-BPV	INSTALL ON 4WEH25-G AND 4WEH25-G VALVES

SUBPLATES

MODEL CODE	DESCRIPTION	WEIGHT (LBS)
SPA08-SP-S20	ALUMINIUM, 3000 PSI, SAE-20, SIDE PORTS	7.6

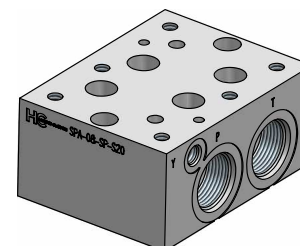

MODULAR VALVES

- COMPACT DESIGN
- MULTIPLE CIRCUITS
- STACKABLE
- AVAILABLE IN ALUMINUM OR STEEL
- LESS OVERCROWDING HOSE AND FITTING LOWERING THE AMOUNT OF LEAK POINT

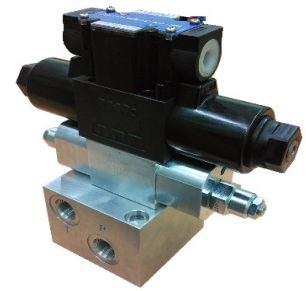

FUNCTION	MODEL CODE	CETOP	MAX GPM	HEIGHT (IN)	PSI RANGE
FLOW CONTROL METER "OUT"	MTCV-02-W-K	D03	9	1.57	-
	MTCV-03-W-K	D05	18	2.16	
COUNTERBALANCE VALVE (PILOT RATIO 3:1)	MH03CDW-CB3H-CB3H-A02	D03	10.5	1.75	1000 - 4000
	MH05CDW-CB3H-CB3H-A01	D05	21	1.95	2000 - 5000
LOCK VALVE (PILOT RATIO 3:1)	Z2S6	D03	13	1.57	-
	Z2S10	D05	21	1.97	
CROSS-OVER RELIEF (A - B)	MH03RDH-RP0A-RP0A-A01	D03	10.5	1.75	1000 - 3000
	MH05RDH-RP0A-RP0A-A01	D05	21	1.95	
PRESSURE RELIEF P TO T PORT	MRV-02-P-3	D03	10.5	1.75	100 - 3000
	MRV-03-P-3	D05	21	1.95	
PRESSURE REDUCING ON "P" PORT	MBRV-02-P-1	D03	9	1.57	100 - 1000
	MBRV-02-P-3				1000 - 3000
	MBRV-03-P-1	D05	18	2.16	100 - 1000
	MBRV-03-P-3				1000 - 3000
DERIVATIVE CIRCUIT	MH03RPJ-10A2-EP02*	D03	10.5	1.75	-
	MH05RPD-CP00-EP02*	D05	21	1.95	

* COIL MUST BE ORDERED SEPARATELY. USE EC04W MODEL

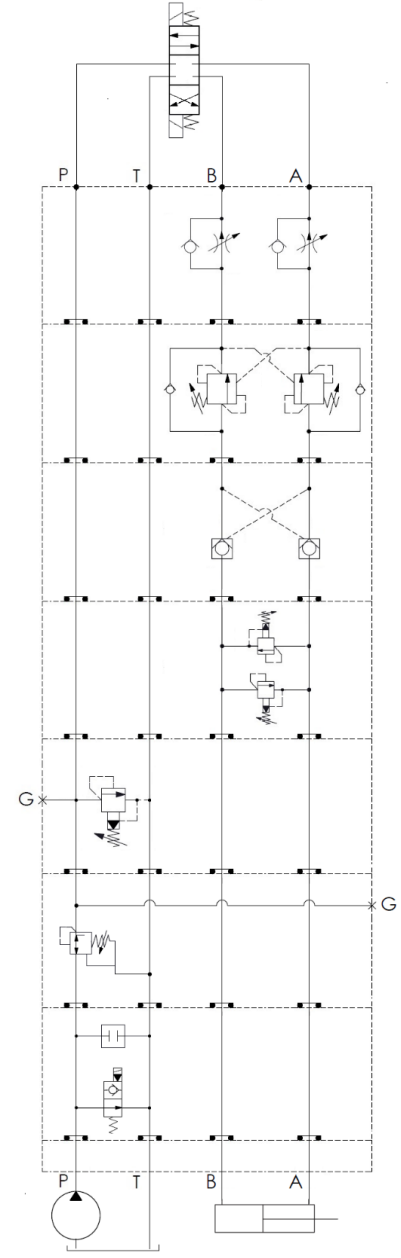

BOLT KITS

MODEL CODE	CETOP	LENGTH
MBK01-325	D03	1.57" + DIR. VLV.
MBK01-350		1.75" + DIR. VLV.
MBK01-490		1.57" + 1.57" + DIR. VLV.
MBK01-500		1.57" + 1.75" + DIR. VLV.
MBK01-525		1.75" + 1.75" + DIR. VLV.
MBK03-350	D05	1.95 OR 2.16" + DIR. VLV
MBK03-550		1.95" + 1.95" + DIR. VLV

- MADE OF ALUMINUM
- 3500 PSI MAXIMUM PRESSURE
- INCLUDES MOUNTING KIT
- RELIEF CAVITY C10-2
- SAE-06 PRESSURE GAUGE PORT



ALSO AVAILABLE

- MORE STATIONS
- STEEL / CAST IRON
- TYPE OF CAVITY FOR RELIEF
- CUSTOMIZED BLOCKS

CETOP D03 MANIFOLDS

SERIE CIRCUIT

MODEL CODE	NUMBER OF STATIONS	PORT SIZE		DIM "L" (IN)	WEIGHT (LBS)
		P & T	A & B		
BMA03 S02 S08 C10-2	2	SAE-10	SAE-08	4.25	3.0
BMA03 S03 S08 C10-2	3			6.37	5.0
BMA03 S04 S08 C10-2	4			8.50	7.0

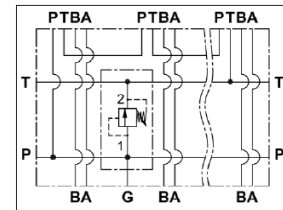

SERIE CIRCUIT WITH OPTIONAL RELIEF VALVE SHOWN

PARALLEL CIRCUIT

MODEL CODE	NUMBER OF STATIONS	PORT SIZE		DIM "L" (IN)	WEIGHT (LBS)
		P & T	A & B		
BMA03 P02 S08 C10-2	2	SAE-10	SAE-08	4.25	3.0
BMA03 P03 S08 C10-2	3			6.37	5.0
BMA03 P04 S08 C10-2	4			8.5	7.0
BMA03 P05 S08 C10-2	5			10.63	9.0
BMA03 P06 S08 C10-2	6			12.75	11.0

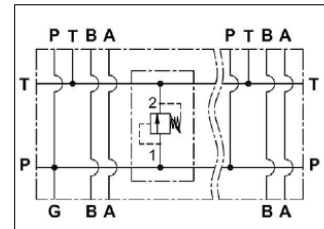

PARALLEL CIRCUIT WITH OPTIONAL RELIEF VALVE SHOWN

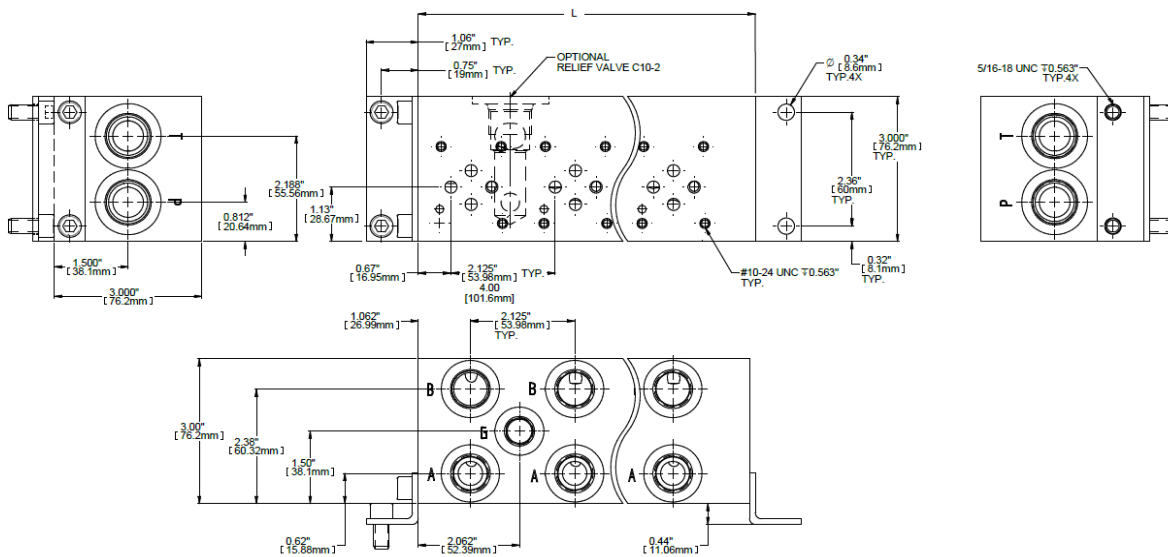

RELIEFS & CAVITY PLUG

MODEL CODE	DESCRIPTION
DE-RVP-00-4000	RELIEF 1000-4000 PSI
CAV-PLUG-10-2	CAVITY PLUG



CETOP D05 MANIFOLDS

SERIE CIRCUIT

MODEL CODE	NUMBER OF STATIONS	PORT SIZE		DIM "L" (IN)	WEIGHT (LBS)
		P & T	A & B		
BMA05 S02 S10 C10-2	2	SAE-12	SAE-10	6.75	6.6
BMA05 S03 S10 C10-2	3			9.75	10.0
BMA05 S04 S10 C10-2	4			13.0	13.3

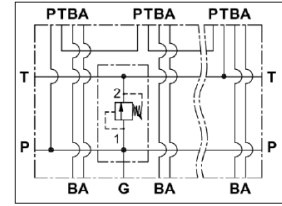

SERIE CIRCUIT WITH OPTIONAL RELIEF VALVE SHOWN

PARALLEL CIRCUIT

MODEL CODE	NUMBER OF STATIONS	PORT SIZE		DIM "L" (IN)	WEIGHT (LBS)
		P & T	A & B		
BMA05 P02 S10 C10-2	2	SAE-12	SAE-10	6.50	6.6
BMA05 P03 S10 C10-2	3			9.75	10.0
BMA05 P04 S10 C10-2	4			13.00	13.3
BMA05 P05 S10 C10-2	5			16.25	16.6

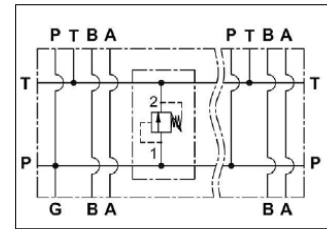

PARALLEL CIRCUIT WITH OPTIONAL RELIEF VALVE SHOWN

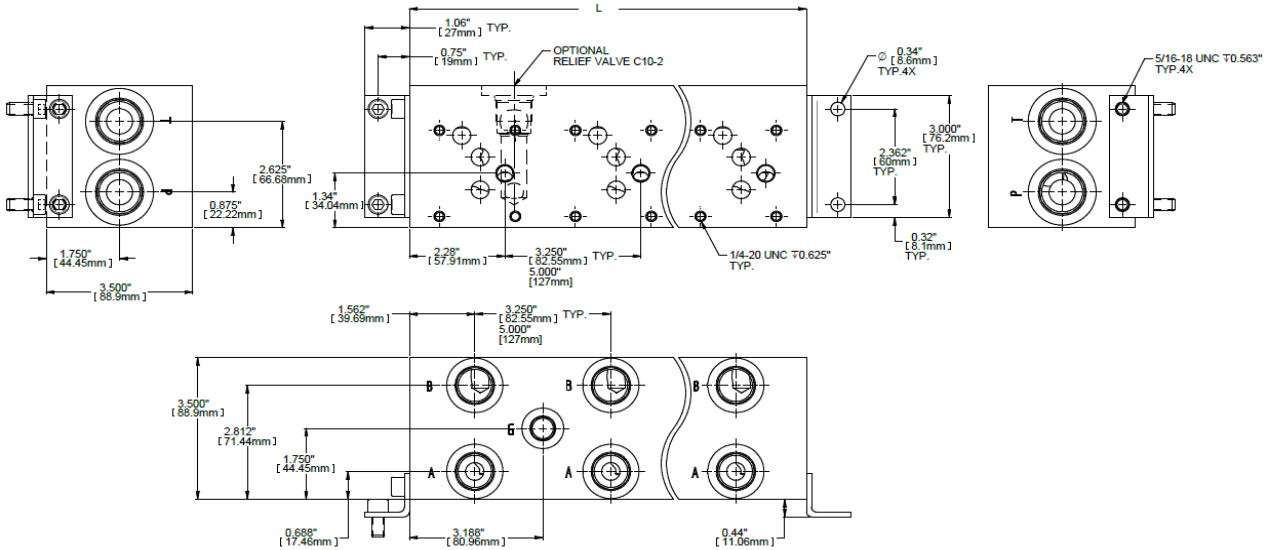

RELIEF & CAVITY PLUG

MODEL CODE	DESCRIPTION
DE-RVP-00-4000	RELIEF 1000-4000 PSI
CAV-PLUG-10-2	CAVITY PLUG



COVER PLATES

MODEL CODE	CETOP	DESCRIPTION
CPA03-XX	D03	ALL PORTS BLOCKED
CPA03-PT		OIL PASSAGE FROM P TO T
CPA05-XX	D05	ALL PORTS BLOCKED
CPA05-PT		OIL PASSAGE FROM P TO T

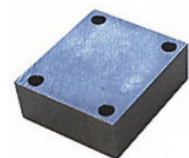

GENERAL SPECIFICATIONS

FEATURES AND BENEFITS

- HYDRAULIC CIRCUIT AND BLOCKS DESIGNED IN NORTH AMERICA
- ONE MANUFACTURE IN NORTH AMERICA
- SUN AND COMMON CAVITIES (OTHER ON REQUEST)
- POSSIBLE TO INTEGRATE CETOP AND SECTIONAL VALVES

FLOW REGULATOR FOR AUXILIARY CIRCUIT



CUSTOMIZED INTEGRATED PRODUCT

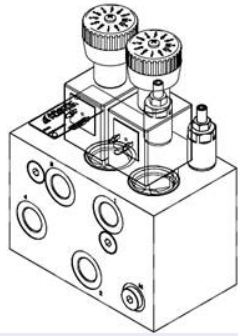
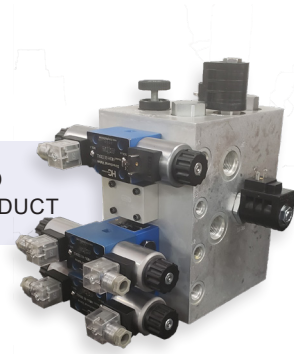

SALT SPRAYER VALVES

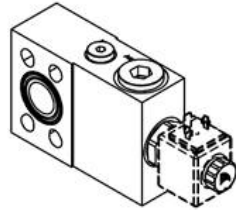

EXCAVATOR VALVES

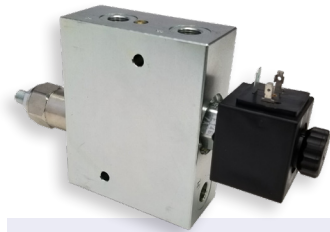

AUXILIARY QUICK HITCH

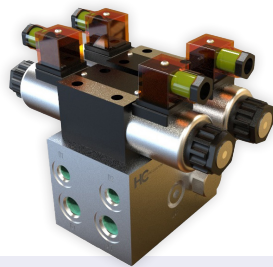

CUSTOMIZED INTEGRATED PRODUCT

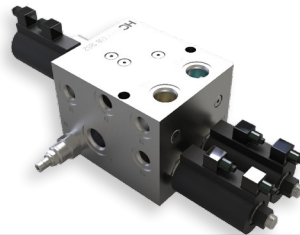

CUSTOMIZED INTEGRATED PRODUCT

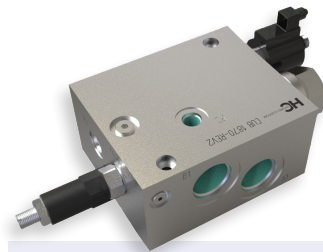

REGENERATION BLOC

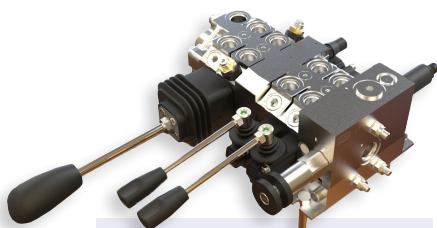

CUSTOMIZED INTEGRATED PRODUCT

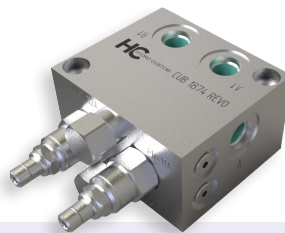

PRESSURE REDUCING BLOCK

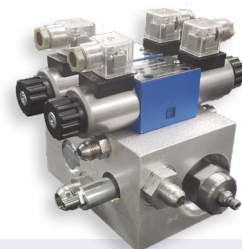

STREET BRUSH BLOCK

2 WAY, 2 POSITION, NORMALLY CLOSED

MODEL CODE	MAX GPM	MAX PSI	CAVITY	COIL	CIRCUIT	WEIGHT (LBS)
PB-S2B-00	8	3500	C8-2	P		0.2
EP08W2A05M05	10	5000		EC04W		0.3
DE-S2B-00	15	3500	C10-2	D		0.3
EP10W2A05M05	17.5	5000		EC04W		0.4
TT-S2B-00	25	3000	C12-2	D		0.5
EP12W2A05M05	37.5	5000		EC04W		0.5
SJ-S2B-00	30	3500	C16-2	D		0.7
EP16W2A05M05	37.5	5000		EC04W		0.7
DE-S2I-00	4	3000	C10-2	D		0.3
EP08W2A31M05	10	5000	C8-2	EC04W		
EP10W2A31M05	17.5	5000	C10-2		0.4	
EP16W2A31M05	37.5	5000	C16-2		0.7	



2 WAY, 2 POSITION, NORMALLY OPEN

MODEL CODE	MAX GPM	MAX PSI	CAVITY	COIL	CIRCUIT	WEIGHT (LBS)	
PB-S2D-00	10	3500	C8-2	P		0.2	
EP08W2A06T05	10	5000		EC04W		0.3	
DE-S2D-00	15	3500	C10-2	D		0.3	
EP10W2A06P05	17.5	5000		EC04W		0.4	
TT-S2D-00	30	3000	C12-2	D		0.5	
EP12W2A06P05	37.5	5000		EC04W		0.5	
SJ-S2D-00	40	3000	C16-2	D		0.7	
EP16W2A06P05	37.5	5000		EC04W		0.7	
EP08W2A32P05	10	5000	C8-2	EC04W			0.3
EP10W2A32P05	17.5	5000	C10-2				0.4
EP16W2A32P05	37.5	5000	C16-2		0.7		



3 WAY, 2 POSITION

MODEL CODE	MAX GPM	MAX PSI	CAVITY	COIL	CIRCUIT	WEIGHT (LBS)
ES08W3A11N04	2.5	3000	C8-3	EC04W		0.3
DF-S3A-00	10	3000	C10-3	D		
TYPICALLY USED FOR SINGLE ACTING CYLINDER						
DF-S3B-00	8	3000	C10-3	D		0.3
TYPICALLY USED AS A SELECTOR						

4 WAY, 2 POSITION

MODEL CODE	MAX GPM	MAX PSI	CAVITY	COIL	CIRCUIT	WEIGHT (LBS)
ES08W4A10N04	3	3000	C8-4	EC04W		0.3
DG-S4A-00	10		C10-4	D		
ES08W4A11N04	4	3000	C8-4	EC04W		
DG-S4B-00	10		C10-4	D		

BODIES

• MADE OF ALUMINUM

• 3000 PSI MAXIMUM PRESSURE

MODEL CODE	CAVITY	PORT SIZE	DIMENSIONS (IN)						WEIGHT (LBS)
			A	B	C	D	E	F	
30102466	C8-2	SAE-06	2.00	2.00	1.25	1.50	1.50	1.50	0.4
30102359	C10-2	SAE-08	2.12	2.00	1.50	1.75	0.50	0.28	0.6
30102364		SAE-06							
30102813	C12-2	SAE-12	3.09	2.75	1.75	2.20	0.84	0.41	1.1
30102331	C16-2	SAE-12	3.00	3.00	2.00	2.44	0.75	0.41	1.8
30102533	C8-3	SAE-06	2.50	2.25	1.25	1.75	0.25	0.28	0.7
30102354	C10-3	SAE-08	2.50	2.50	1.50	2.25	0.38	0.28	1.1
30102535	C8-4	SAE-06	3.00	2.25	1.25	1.75	0.50	0.28	0.9
30102367	C10-4	SAE-08	3.25	2.50	1.50	2.25	0.38	0.28	1.0

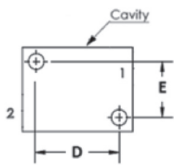

C8-2 BODY

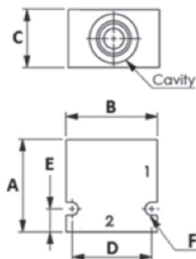

C10-2 TO C16-2 BODIES

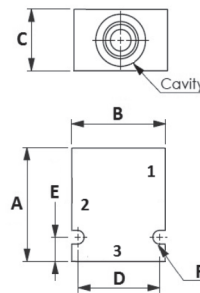

C8-3 AND C10-3 BODIES

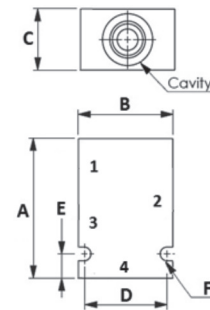

C8-4 AND C10-4 BODIES

COILS

• DIN CONNECTOR MODELS

• OTHER VOLTAGE AND TYPES AVAILABLE

MODEL CODE	VOLTAGE	WATTS	DIMENSIONS (IN)			WEIGHT (LBS)
			INSIDE	HEIGHT	WIDTH	
P-HC-12	12 VDC	19	1/2"	1.78	1.25	0.7
P-HC-24	24 VDC					
P-HC-11	110 VAC					
D-HC-12	12 VDC	22	1/2"	2.03	1.56	0.7
D-HC-24	24 VDC					
D-HC-11	110 VAC					
L-HC-12	12 VDC	22	5/8"	2.03	1.56	0.7
L-HC-24	24 VDC					
L-HC-11	110 VAC					
T-HC-12	12 VDC	28	3/4"	1.96	2.38	0.9
T-HC-24	24 VDC					
T-HC-11	110 VAC					
EC04W-200HE	12 VDC	20	1/2"	1.41	1.51	0.5
EC04W-200HD	24 VDC					
EC04W-200HB*	110 VAC					

* MUST BE USED WITH A DIN CONNECTOR, RECTIFIER



DIN CONNECTORS

MODEL CODE	DESCRIPTION
43650A-DC-BLK	NO LED
ED30R01A	LED, RECTIFIER (AC TO DC)
43650A-DC-LED	LED, 12V/ 24V DC/AC
43650A-110AC-LED	LED, 110V DC/AC



3 WAY DIVERTERS

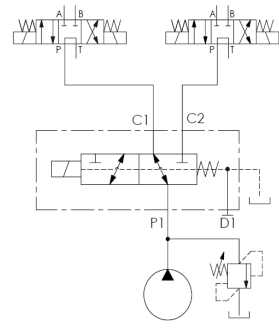

TYPICAL APPLICATION

MODEL CODE	MAX GPM	MAX PSI	PORT SIZE	VOLTAGE	TRANSITION	CIRCUIT
VS85-A-12VDC	16	3625	SAE-08	12 VDC	CLOSED	 ES & VS MODELS
VS85-A-24VDC				24 VDC		
HVC-3/2-10-N-S08-12	21	3000		12 VDC		
HVC-3/2-10-N-S08-24				24 VDC		
VS95-A-12VDC	37	3625	SAE-12	12 VDC	CLOSED	 HVC MODEL
ES000314				24 VDC		
VS95-A-24VDC				24 VDC		
ES000315						
VS85-D-12VDC	16	3625	SAE-08	12 VDC	CLOSED	
VS85-D-24VDC				24 VDC		
VS95-D-12VDC	37	3625	SAE-12	12 VDC		
VS95-D-24VDC				24 VDC		

DIMENSIONS

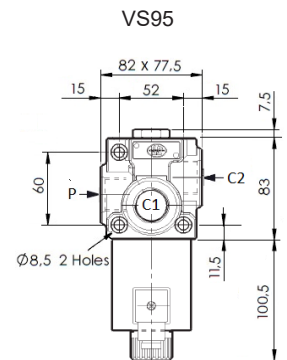
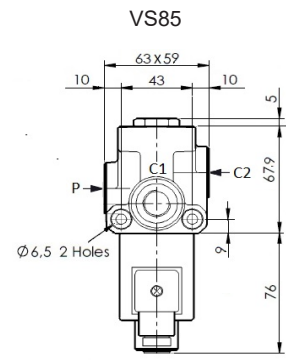
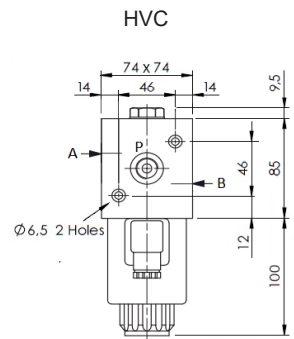
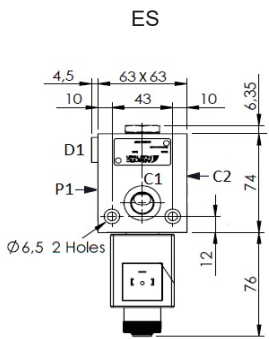

COILS

- DIN CONNECTOR MODELS
- OTHER VOLTAGE & TYPE OF CONNECTORS AVAILABLE

MODEL CODE	VOLTAGE	FITS ON
271-0520	12 VDC	VS85, VS155 & VS245F
271-0521	24 VDC	
281-0617	12 VDC	VS95, VS315 & VS285F
281-0618	24 VDC	
AB000167	12 VDC	ES000312 / 318 / 320
AB000168	24 VDC	ES000313 / 319 / 321

MODEL CODE	VOLTAGE	FITS ON
4WE6-12VDC COIL DIN	12 VDC	KVH, 2KVH & MOP
4WE6-24VDC COIL DIN	24 VDC	
4WE10-12VDC COIL DIN	12 VDC	HVC-3/2 & SVK10
4WE10-24VDC COIL DIN	24 VDC	
AB000156	12 VDC	ES000314 / 316
AB000157	24 VDC	ES000315 / 317

6 WAYS DIVERTERS

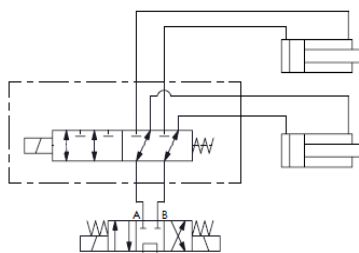

TYPICAL APPLICATION



VS 315

MODEL CODE	MAX GPM	MAX PSI	PORT SIZE	VOLTAGE	TRANSITION	CIRCUIT	
KVH6-S08-DC1200	13	3625	SAE-08	12 VDC	CLOSED	 KVH MODELS	
ES000320				24 VDC			
KVH6-S08-DC2400				24 VDC*			OPEN
ES000321				24 VDC*			
ES000479	16	3625	SAE-08	12 VDC	CLOSED	 ES & VS MODELS	
VS155-12VDC				24 VDC			
VS155-24VDC	26	4500	SAE-10	24 VDC*	OPEN		
ES000473				24 VDC*			
ES000316	37	3625	SAE-12	12 VDC	CLOSED	 ES & VS MODELS	
VS315-12VDC				24 VDC			
ES000317				24 VDC			CLOSED
VS315-24VDC							
ES000307	47	4500	SAE-12	24 VDC*	CLOSED	 ES & VS MODELS	
ES000477				24 VDC*	OPEN		

* DEUTSCH DT04-2P CONNECTOR

DIMENSIONS

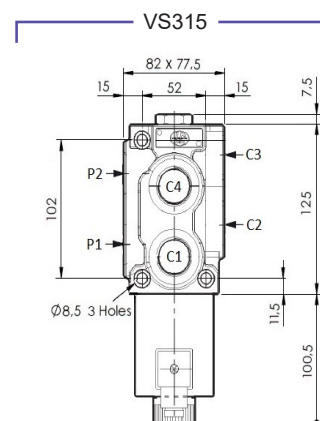
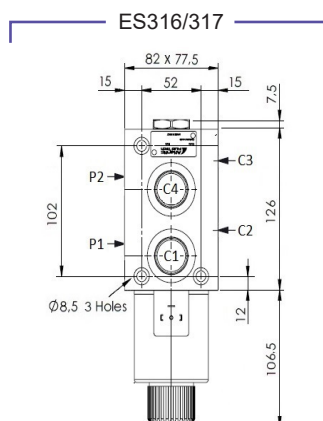
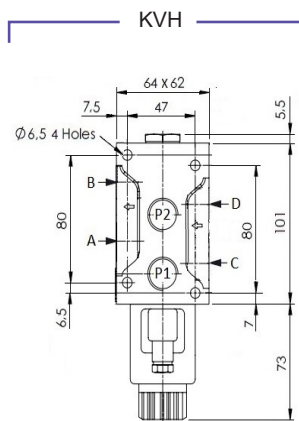
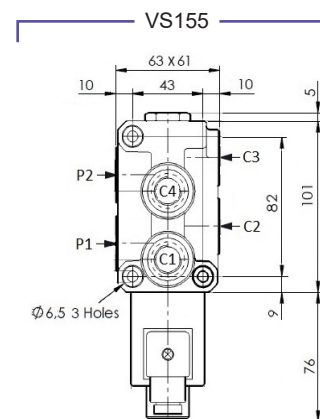
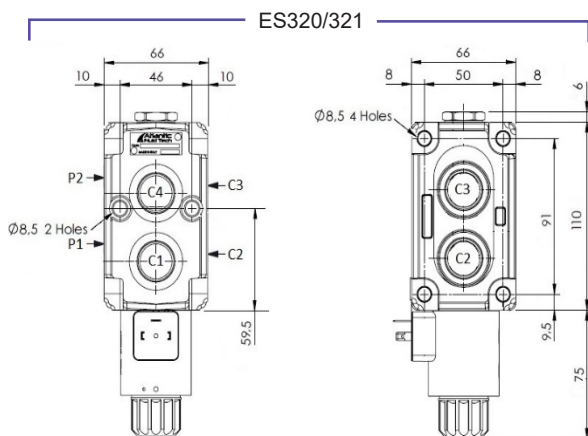

DIVERTERS 8 WAYS - MONOBLOCK

• CLOSED CENTER IN TRANSITION

MODEL CODE	MAX GPM	MAX PSI	PORT SIZE	VOLTAGE
2KVH6-DC12-S08	13.5	3625	SAE-08	12 VDC
2KVH6-DC24-S08				24 VDC

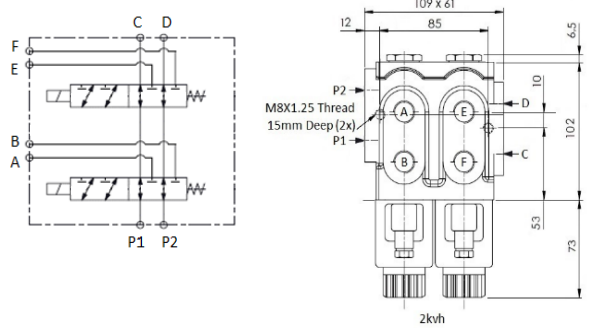
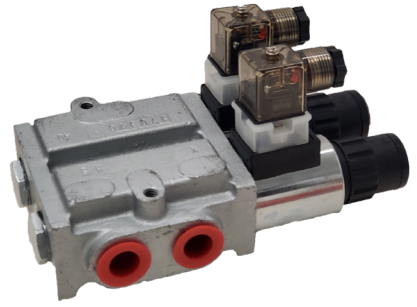

DIVERTERS 6 WAYS - STACKABLE

• CLOSED CENTER IN TRANSITION

MODEL CODE	MAX GPM	MAX PSI	PORT SIZE	VOLTAGE
VS125F-12VDC	6.5	3625	SAE-04	12 VDC
MOP066-S08-I1-DC12	13.5	3625	SAE-08	12 VDC
MOP066-S08-I1-DC24				24 VDC
VS245F-12VDC	13.5	3625	SAE-08	12 VDC
VS245F-24VDC				24 VDC
ES000318	13.5	3625	SAE-08	12 VDC
ES000319				24 VDC
ES000312	13.5	3625	SAE-10	12 VDC
ES000313				24 VDC
SVK10-DC12-S10-N1	21	3625	SAE-10	12 VDC
SVK10-DC24-S10-N1				24 VDC
VS285F-12VDC	24	3625	SAE-10	12 VDC
VS285F-24VDC				24 VDC

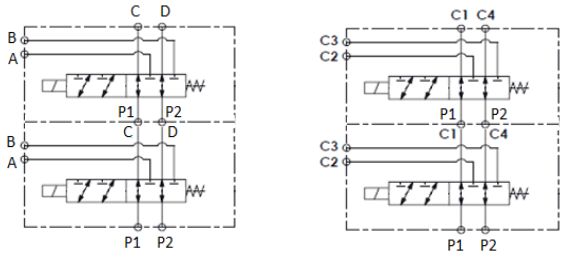

MOP & SVK MODELS
8 WAYS SHOWN

ES & VS MODELS
8 WAYS SHOWN

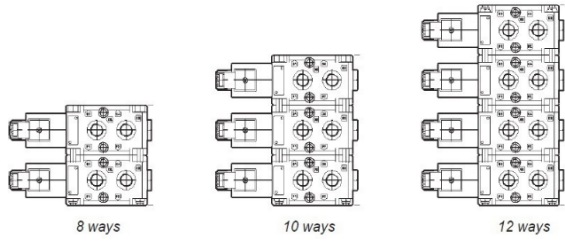

8 ways

10 ways

12 ways

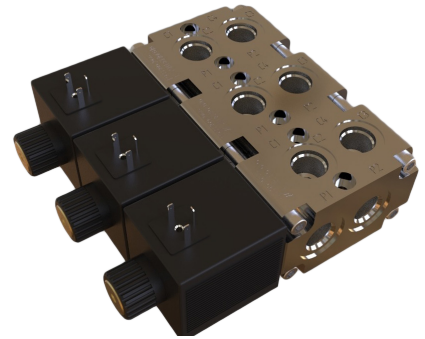

DIMENSIONS

SKV 8 WAYS

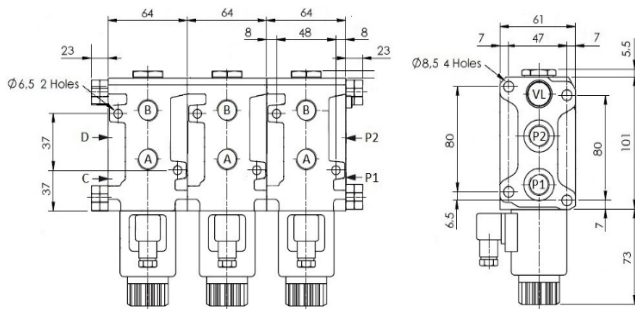

MOP 10 WAYS

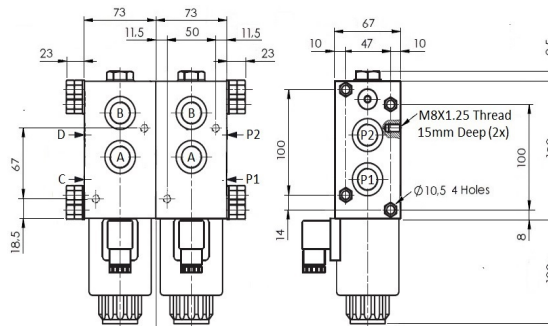

VS285F 8 WAYS

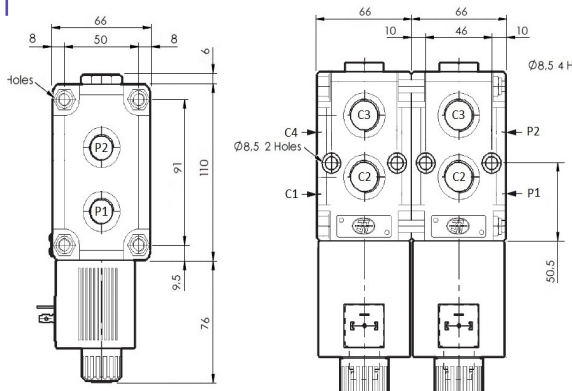

ES 8 WAYS

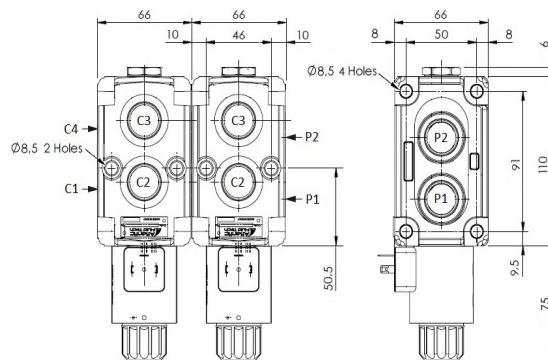

VS245F 8 WAYS

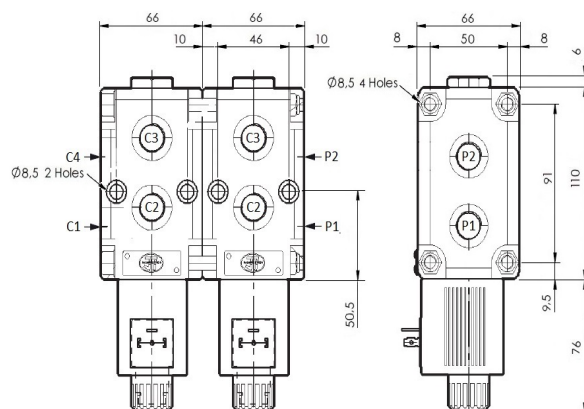

ELECTRIC HANDLES

- CABLES TERMINAL SUPPLIED WITHOUT LEAD-IN WIRE
- MAX CURRENT ON CONTACTS : 3 AMPERE
- SAFETY PUSH BUTTON ON REQUEST
- ELECTRICAL LIFE : 10⁶ CYCLES (1 CYCLE = 2 SEC. "ON" / 2 SEC. OFF WITH CURRENT = 3A VOLTAGE = 12VDC AND WITH ARC SUPPRESSOR DIODE)
10⁵ CYCLES IF USED WITH CURRENT = 3A VOLTAGE = 12VDC AND WITH DIRECT CONNECTION

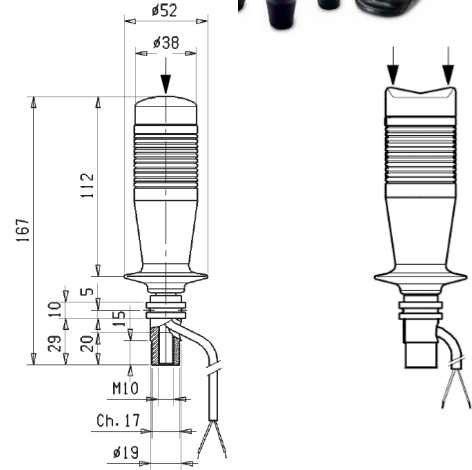

ECONOMIC HANDLES

MODEL CODE	DESCRIPTION
G9466012331	1 CONTACT
G9466012351	2 CONTACTS
E9634005553	2 DETENTS

ERGONOMICAL HANDLES

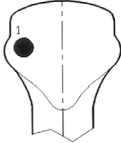
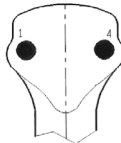
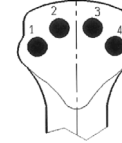
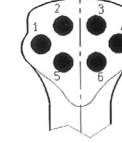
NUMBER OF PUSH BUTTONS			
E9634006903	E9634006893	E9634006923	E9634006913
			

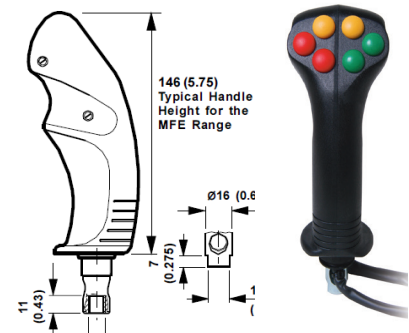

3 WAYS PUSH-PULL DIVERTERS

- DIRECTS THE FLOW OF OIL INTO TWO SEPARATE HYDRAULIC CIRCUITS
- OPEN CENTER IN TRANSITION
- SHIFT VALVE BEFORE PRESSURE IS APPLIED



SS MODELS

BAILEY PART NO	MODEL CODE	PORT SIZE	MAX PSI	MAX GPM	WEIGHT (LBS)
222999	SS-2A1D	1/2 NPT	2500	20	4.0
223005	SS-3A1D	SAE-08			
220936	SV80-A-S8-K	SAE-08	3000	20	3.2
220937	SV120-A-S12-K	SAE-12			



SV MODELS

6 WAYS PUSH-PULL DIVERTERS - PRINCE

- DIRECTS THE FLOW OF OIL INTO TWO SEPARATE HYDRAULIC CIRCUITS
- OPEN CENTER IN TRANSITION

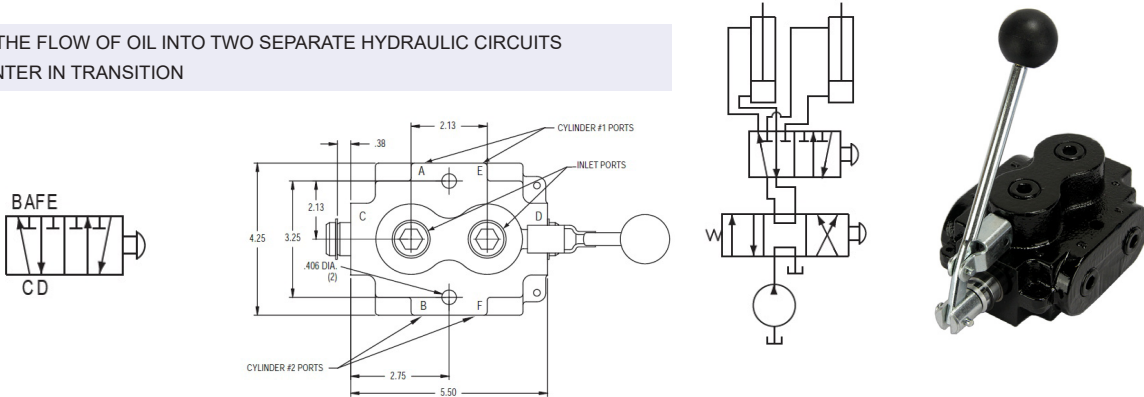

BAILEY PART NO	MODEL CODE	PORT SIZE	MAX PSI	MAX GPM	WEIGHT (LBS)
222996	DS-1A1E	1/2 NPT	2500	20	9.0
222998	DS-4A1E	3/4 NPT		40	

3 WAYS ROTARY DIVERTERS

- CLOSED TRANSITION
- OPEN TRANSITION ALSO AVAILABLE

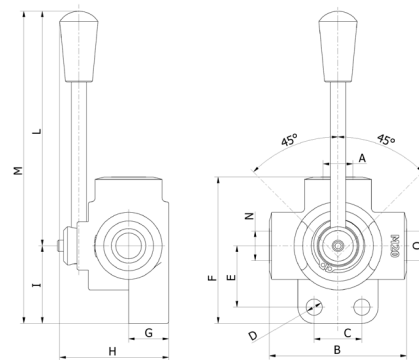
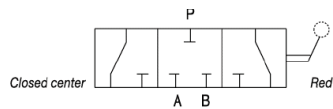

MODEL CODE	PORT SIZE	MAX PSI	MAX GPM	DIMENSIONS (IN)								WEIGHT (LBS)	
				B	C	D	E	F	G	H	L		M
FD3W-02-C-S	SAE-08	5000	16	2.76	1.0	0.33	1.26	2.97	0.83	2.24	4.53	6.12	1.7
FD3W-03-C-S	SAE-10		24	3.15	1.26	0.33	1.42	3.39	0.94	2.48	4.53	6.34	2.6
FD3W-04-C-S	SAE-12		32	3.54	1.26	0.41	1.65	3.88	1.02	2.64	4.53	6.63	3.9

6 WAYS ROTARY DIVERTERS

- CLOSED TRANSITION
- OPEN TRANSITION ALSO AVAILABLE

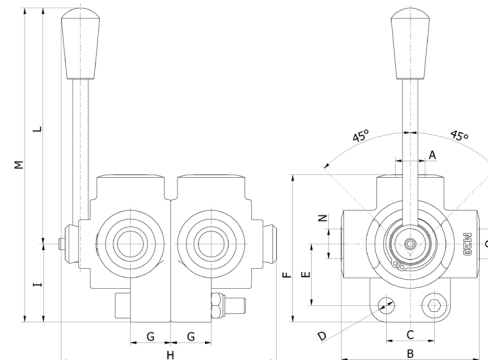
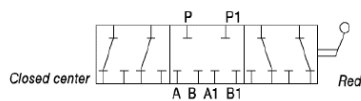

MODEL CODE	PORT SIZE	MAX PSI	MAX GPM	DIMENSIONS (IN)								WEIGHT (LBS)	
				B	C	D	E	F	G	H	L		M
FD6W-02-C-S	SAE-08	5000	16	2.76	1.0	0.33	1.26	2.97	0.83	4.41	4.53	6.12	3.3
FD6W-03-C-S	SAE-10		24	3.15	1.26	0.33	1.42	3.39	0.94	4.88	4.53	6.34	5.0
FD6W-04-C-S	SAE-12		32	3.54	1.26	0.41	1.65	3.88	1.02	5.20	4.53	6.63	7.7

HIGH PRESSURE BALL VALVES

- ZINC PLATED STEEL BODY
- TEMPERATURE: -25 TO 100°C

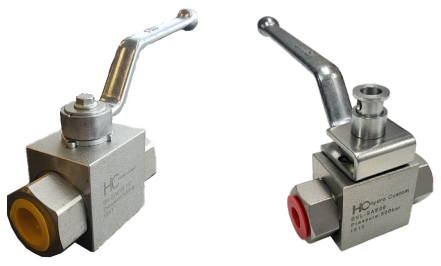

2 WAYS

BVL-SAExx MODELS

MODEL CODE	PORT SIZE	MAX PSI
BV-1/4NPT	1/4 NPT	7250
BV-3/8NPT	3/8 NPT	
BV-1/2NPT	1/2 NPT	
BV-3/4NPT	3/4 NPT	5800
BV-1NPT	1" NPT	5075
BV-SAE04*	SAE-04	7250
BV-SAE06*	SAE-06	
BV-SAE08*	SAE-08	
BV-SAE12*	SAE-12	4500
BV-SAE16	SAE-16	
BV-SAE20*	SAE-20	
BV-SAE24*	SAE-24	

3 WAYS

MODEL CODE	PORT SIZE	MAX PSI
BV3-3/8NPT	3/8 NPT	7250
BV3-1/2NPT	1/2 NPT	
BV3-3/4NPT	3/4 NPT	5800
BV3-1NPT	1" NPT	5800
BV3-SAE04	SAE-04	4500
BV3-SAE06	SAE-06	
BV3-SAE08	SAE-08	
BV3-SAE12	SAE-12	
BV3-SAE16	SAE-16	
BV3-SAE20	SAE-20	

*AVAILABLE WITH LOCKING DEVICE
BVL-SAExx MODELS

IN-LINE CHECK VALVES

- FREE FLOW IN ONE DIRECTION ONLY
- MATERIAL: ZINC PLATED STEEL BODY

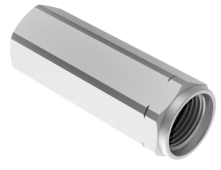
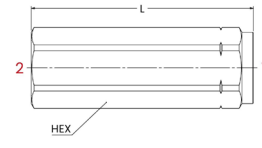
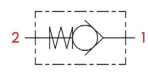

BAILEY PART NO	MODEL CODE	PORT SIZE	MAX PSI	MAX GPM	DIMENSIONS		WEIGHT (LBS)
					L (IN)	HEX (MM)	
7 PSI CRACKING PRESSURE							
280400	CV-04N	1/4 NPT	5800	8	2.28	19	0.22
280402	CV-06N	3/8 NPT	5800	12	2.71	22	0.4
280404	CV-08N	1/2 NPT	5800	18.5	2.95	27	0.5
280406	CV-12N	3/4 NPT	5800	29	3.48	35	1.0
280408	CV-16N	1" NPT	5075	42	4.33	41	1.6
280410	CV-06S	SAE-06	5800	8	2.71	22	0.2
280411	CV-08S	SAE-08	5800	13	2.95	27	0.4
280412	CV-12S	SAE-12	5800	24	3.48	35	1.0
65 PSI CRACKING PRESSURE							
280401	CV-04N-65	1/4 NPT	5800	8	2.28	19	0.22
280403	CV-06N-65	3/8 NPT	5800	12	2.71	22	0.4
280405	CV-08N-65	1/2 NPT	5800	18.5	2.95	27	0.5
280407	CV-12N-65	3/4 NPT	5800	29	3.48	35	1.0
280409	CV-16N-65	1" NPT	5075	42	4.33	41	1.6

CARTRIDGE TYPE CHECK VALVES

- FREE FLOW IN ONE DIRECTION ONLY

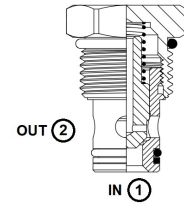

FREE FLOW NOSE TO SIDE

MODEL CODE	MAX GPM	MAX PSI	CRACKING PSI	CAVITY	
MA-CVA-00-0005	5	3500	5	C7-2	
CV08W-2007-N	8	3500	10	C8-2	
CV08W-2041N			60		
PB-CVC-00-0005	10	3500	5	T-162A	
CV162A-2020N	10	5000	30		
DE-CVA-00-0005	15	3500	5	C10-2	
CV10W-2003N			35		
DE-CVA-00-0035					90
DE-CVA-00-0090					
HE-CVA-00-0150			5000		150

MODEL CODE	MAX GPM	MAX PSI	CRACKING PSI	CAVITY
SJ-CVA-00-0005	40	3500	5	C16-2
SJ-CVA-00-0030			30	
CV5A-2003N	42	5000	4	T-5A
CV5A-2020N			30	
CV5A-2050N			75	
CV16A-2003N	84	5000	4	T-16A
CV16A-2010N			15	
CV16A-2020N			30	
CV16A-2070N			100	

REVERSE (FREE FLOW SIDE TO NOSE)

MODEL CODE	MAX GPM	MAX PSI	CRACKING PSI	CAVITY
CV162A-2103N	8	5000	4	T-162A
DE-CVR-00-0005	15	3500	5	C10-2
CV16A-2120N	63	5000	30	T-16A
CV16A-2135N			60	

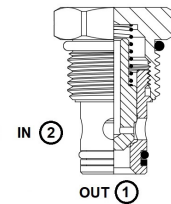
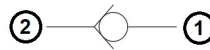

LINE MOUNT BODIES

- MATERIAL: ANODIZED ALUMINUM
- 3000 PSI MAXIMUM PRESSURE
- DUCTILE IRON AVAILABLE ON DEMAND

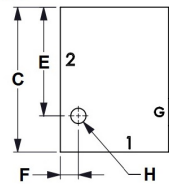
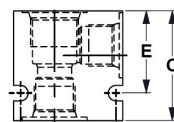
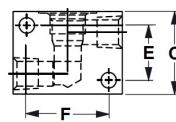
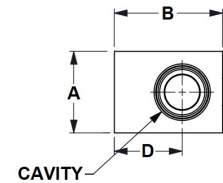
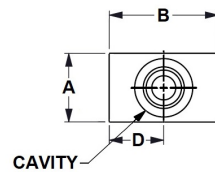
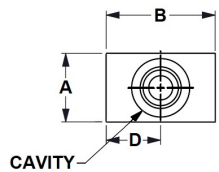

C8-2 CAVITY

C10-2 & C16-2 CAVITIES

T-* CAVITIES

MODEL CODE	CAVITY	PORT SIZE	DIMENSIONS (INCHES)							
			A	B	C	D	E	F	G	H
30102466	C8-2	SAE-06	1.25	2.0	2.0	1.125	1.5	1.5		
30102364	C10-2	SAE-06	1.5	2.0	2.0	1.25	1.5	1.75		
30102359		SAE-08								
30102331	C16-2	SAE-12	2.0	3.0	3.0	1.875	2.25	2.438		
ML-162A2-S06-A01	T-162A	SAE-06	1.0	1.50	2.0	1.0	1.72	0.28		0.28
ML-5A2-S08-A01	T-5A	SAE-08	1.5	2.0	2.625	1.5	2.25	0.375		0.42
ML-5A2-S10-A01		SAE-10								
ML-16A2-S12G-A01	T-16A	SAE-12	2.25	3.0	4.0	1.88	3.0	0.5	1/4 NPT	0.42
ML-16A2-S16G-A01		SAE-16								

SHUTTLE VALVES - HYDRO-CUSTOM

• MATERIAL: ZINC PLATED STEEL BODY

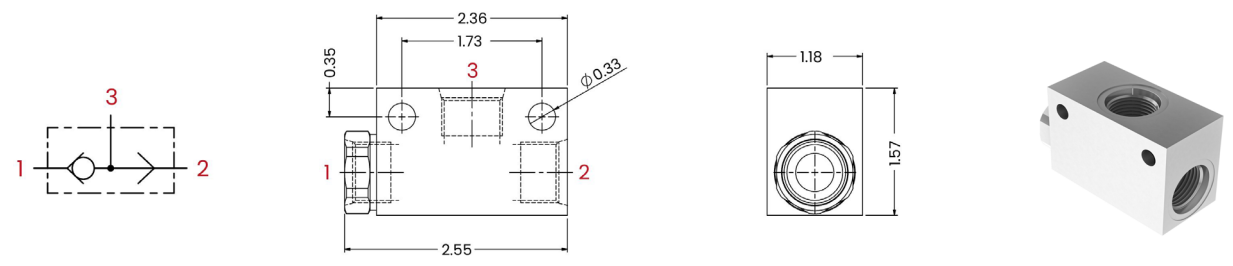

BAILEY PART NO	MODEL CODE	PORT SIZE	MAX PSI	MAX GPM	WEIGHT (LBS)
280419	SHV-06S	SAE-06	5075	7.9	0.65

SINGLE PILOT OPERATED CHECK VALVES - HYDRO-CUSTOM

• MATERIAL: ZINC PLATED STEEL BODY

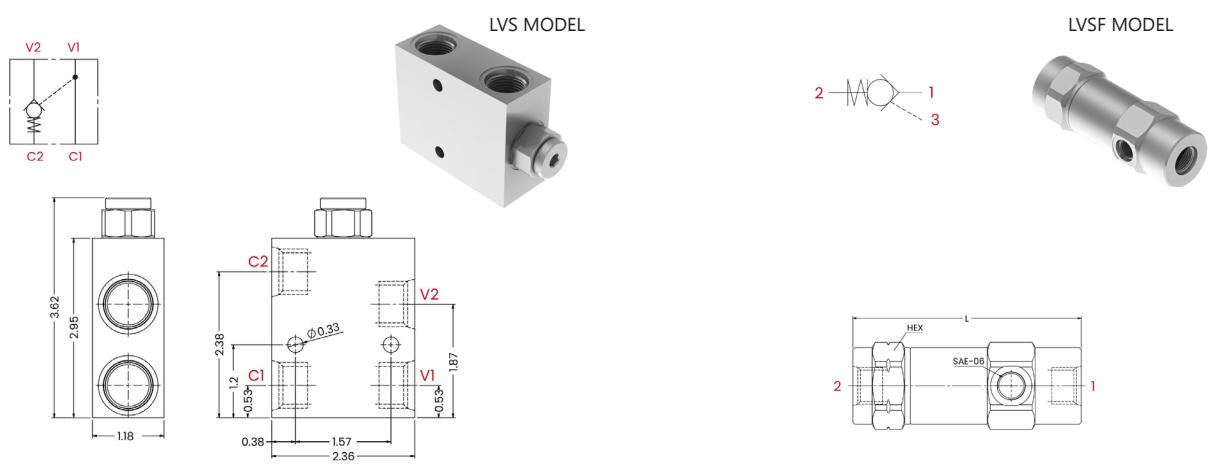

BAILEY PART NO	MODEL CODE	PORT SIZE	MAX PSI	MAX GPM	PILOT RATIO	CRACKING PSI	WEIGHT (LBS)
280413	LVS-08S	SAE-08	5075	9.2	7 : 1	65	1.9
280414	LVSF-08S			10.6	5 : 1		2.3

SINGLE PILOT OPERATED CHECK VALVES - DELTA-POWER & PRINCE

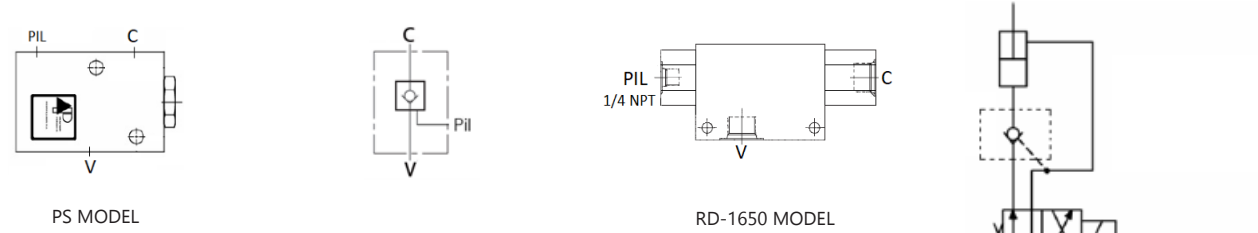

BAILEY PART NO	MODEL CODE	PORT SIZE	MAX PSI	MAX GPM	PILOT RATIO	WEIGHT (LBS)
	PS-POC-BS	SAE-06	3000	10	4:1	1.0
222180	RD-1650	1/2 NPT	3000	20	4:1	2.0

DOUBLE PILOT OPERATED CHECK VALVES - HYDRO-CUSTOM

• MATERIAL: ZINC PLATED STEEL BODY

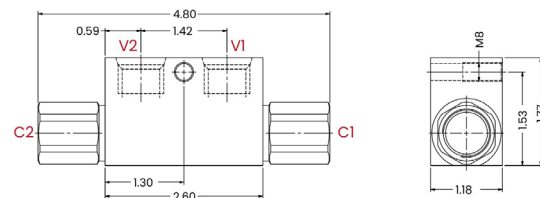
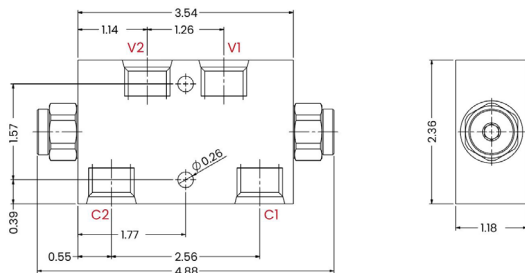
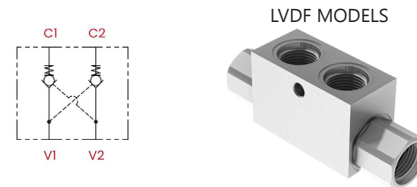
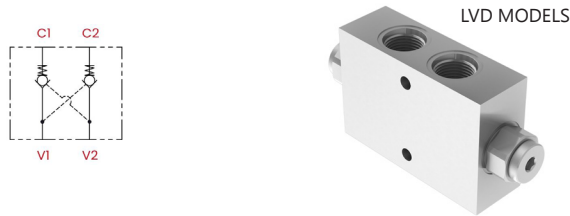

BAILEY PART NO	MODEL CODE	PORT SIZE	MAX PSI	MAX GPM	PILOT RATIO	CRACKING PSI	WEIGHT (LBS)
280415	LVDF-06S	SAE-06	5075	5.3	5.5 : 1	65	1.4
280417	LVD-06S				3.3 : 1		2.9
280416	LVDF-08S	SAE-08	5075	9.2	5.5 : 1	65	1.3
280418	LVD-08S				3.3 : 1		2.6

DOUBLE PILOT OPERATED CHECK VALVES

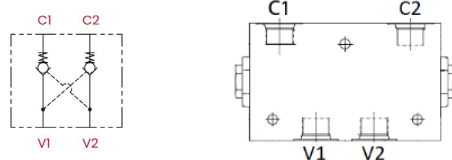

RD-1450

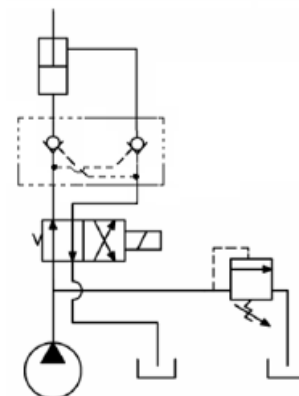

BAILEY PART NO	MODEL CODE	PORT SIZE	MAX PSI	MAX GPM	PILOT RATIO	WEIGHT (LBS)
	PD-POC-BS	SAE-06	3000	10	4:1	1.2
222574	RD-1450	1/2 NPT	3000	30	4:1	7.0

COUNTERBALANCE VALVES ARE USED TO KEEP A LOAD LOCKED. THE BUILT-IN RELIEF CONTROL THE LOAD AND LIMIT THE PRESSURE IN THE ACTUATOR. SINCE THESE 2 MODELS ARE ATMOSPHERICALLY VENTED, THEY ARE NOT AFFECTED BY BACK PRESSURE SO THEY CAN BE USED IN A SYSTEM USING DIRECTIONAL VALVES THAT HAS PORTS CLOSED IN NEUTRAL POSITION.

IN THIS CASE, THE LOCK FUNCTION WORKS HOWEVER IT LOSES HIS RELIEF FUNCTION IN NEUTRAL POSITION. IF THEY ARE USED WITH DIRECTIONAL VALVES THAT HAS OPEN PORTS IN NEUTRAL POSITION, THEY WORK EXACTLY AS A REGULAR COUNTERBALANCE VALVE.

SINGLE COUNTERBALANCE VALVES

• MATERIAL: ZINC PLATED STEEL BODY

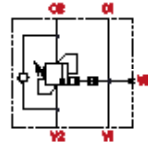
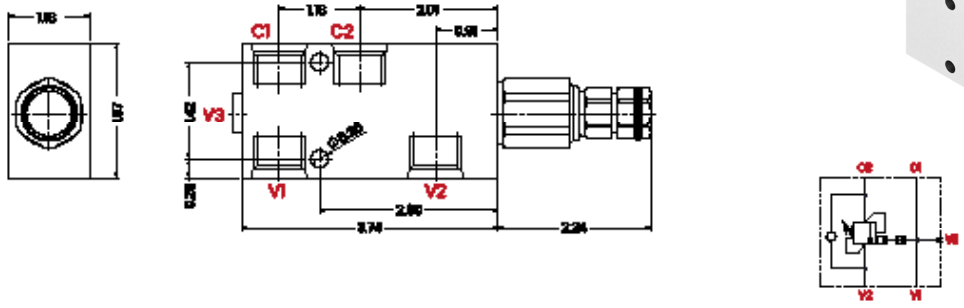

BAILEY PART NO	MODEL CODE	PORT SIZE	MAX PSI	MAX GPM	PSI RANGE	PILOT RATIO	WEIGHT (LBS)
280420	SCBC-08S-30	SAE-08	5075	10	435 - 3045	4:1	2.0

DUAL COUNTERBALANCE VALVES

• MATERIAL: ZINC PLATED STEEL BODY

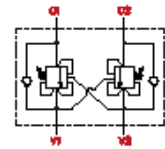
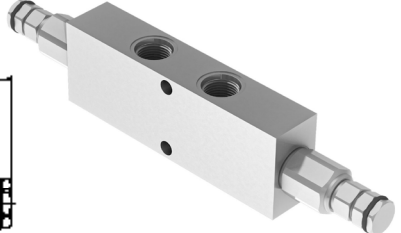
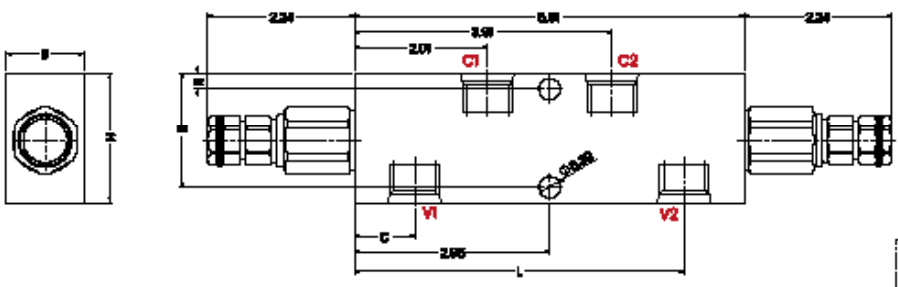

BAILEY PART NO	MODEL CODE	PORT SIZE	MAX PSI	MAX GPM	PSI RANGE	PILOT RATIO	WEIGHT (LBS)
280422	DCBC-08S-30	SAE-08	5075	10	435 - 3045	4:1	2.0

PILOT OPERATED CHECK VALVES - WINNER

MODEL CODE	MAX PSI	MAX GPM	CAVITY	PILOT RATIO	WEIGHT (LBS)
CO08W3-317N	5000	8	C8-3	3:1	0.4
CO11A-30-20N		15	T-11A		0.3
CO2A-30-20N		30	T-2A		0.5
CO17A-30-20N		60	T-17A		1.1
CO19A-30-20N		120	T-19A		2.6

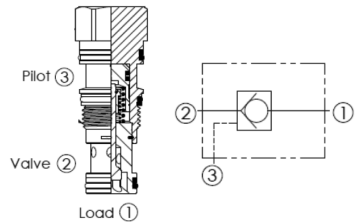

COUNTERBALANCE VALVES

MODEL CODE	MAX PSI	MAX GPM	CAVITY	PSI RANGE	PILOT RATIO	WEIGHT (LBS)	
CB11A-33-I-L	4000	15	T-11A	360 - 1500	3:1	0.34	
CB11A-33-H-L*				1000 - 4000			
CB11A-3C-H-L*				1000 - 2500	4.5:1		
CB11A-34-K-L	2000 - 5000						
CB11A-34-J-L	5000	30	T-2A	1000 - 2500	4.5:1		
CB11A-30-K-L				1000 - 2500			
CB11A-30-J-L				2000 - 5000	10:1		
CB2A-33-I-L	4000	30	T-2A	360 - 1500	3:1	0.6	
CB2A-3C-H-L*				1000 - 4000			
CB2A-33-H-L				1000 - 2500	4.5:1		
CB2A-34-K-L	2000 - 5000						
CB2A-34-J-L	5000	60	T-17A	1000 - 2500	4.5:1		
CB2A-30-J-L				2000 - 5000			10:1
CB17A-3C-I-L				4000	120	T-19A	360 - 1500
CB17A-3C-H-L	1000 - 4000						
CB17A-3D-J-L	1000 - 2500	4.5:1					
CB17A-3J-J-L	2000 - 5000		10:1				
CB19A-3C-H-L*	4000	120	T-19A	1000 - 4000	3:1	3.0	
CB19A-3D-K-L				1000 - 2500			
CB19A-3J-J-L				2000 - 5000	10:1		

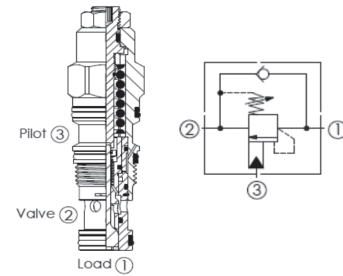

* SEALED PILOT

LINE MOUNT BODIES

- MATERIAL: ANODIZED ALUMINUM
- 3000 PSI MAXIMUM PRESSURE
- DUCTILE IRON AVAILABLE ON DEMAND

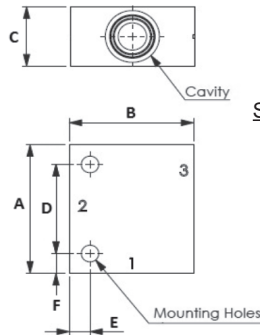

SINGLE BODY

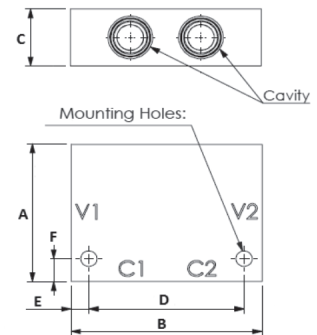

DOUBLE BODY

SINGLE BODIES

MODEL CODE	CAVITY	PORTS 1 & 2	PORT 3	DIMENSIONS							WEIGHT (LBS)
				A	B	C	D	E	F	HOLES (2)	
ML-11A3-S06-A01	T-11A	SAE-06	SAE-06	3.00	2.52	1.26	2.12	0.38	0.44	0.34	0.8
ML-11A3-S08-A01		SAE-08	SAE-06								
ML-2A3-S12A-A01	T-2A	SAE-12	SAE-06	3.25	3.00	1.50	2.25	0.50	0.50	0.42	1.2
ML-17A3-S16-A01	T-17A	SAE-16	SAE-06	4.25	4.00	2.36	2.75	0.75	0.75		3.3
ML-19A3-S16G-A03	T-19A	SAE-16	SAE-06	5.00	5.00	3.00	4.00	0.50	0.50	5.8	

DOUBLE BODIES

MODEL CODE	CAVITY	PORT SIZE	DIMENSIONS							WEIGHT (LBS)
			A	B	C	D	E	F	HOLES (2)	
ML-60-CDW-11A3-11A3-S06-A01	T-11A	SAE-06	3.00	4.00	1.25	3.25	0.37	0.50	0.34	1.5
ML-60-CDW-11A3-11A3-S08-A01		SAE-08								
ML-120-CDW-2A3-2A3-S12-A01	T-2A	SAE-12	3.25	4.50	1.50	3.50	0.50	0.50	0.42	1.6
ML-240-CDW-17A3-17A3-S16-A01	T-17A	SAE-16	4.00	6.50	2.36	5.00	0.75	0.75		4.9

DIRECT ACTING - HYDRO-CUSTOM

• MATERIAL: ZINC PLATED STEEL BODY

BAILEY PART NO	MODEL CODE	PORT SIZE	MAX PSI	MAX GPM	PSI RANGE	WEIGHT (LBS)
280424	RV10-08S-30	SAE-08	5000	10.5	295 - 3000	2.0
280425	RV10-10S-30	SAE-10		13		
280430	RV20-10S-14	SAE-10		21	145 - 1450	2.0
280426	RV20-10S-36	SAE-10		21	290 - 3600	2.0
280427	RV20-12S-36	SAE-12	21	2.3		
280431	RV42-16S-50	SAE-16	5000	42	725 - 5000	6.3



RV10 DIMENSIONS

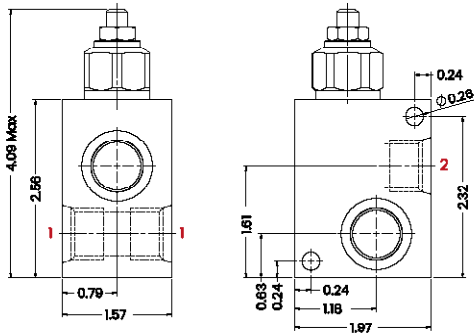

RV42 DIMENSIONS

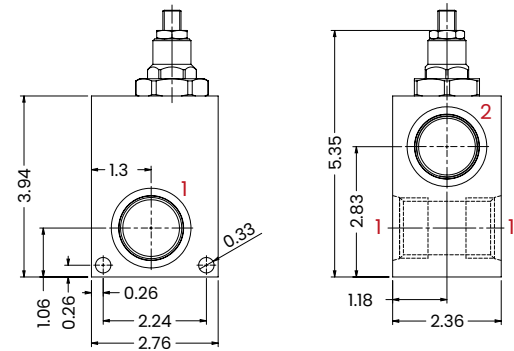

RV20 DIMENSIONS

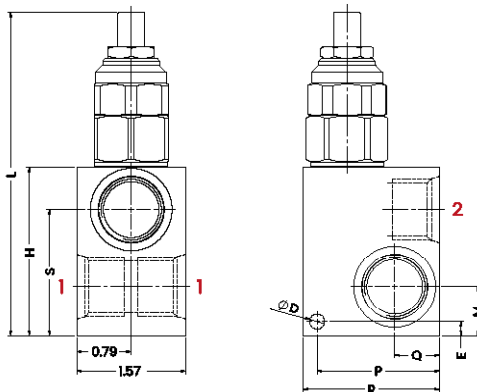

MODELS	DIMENSIONS (IN)								
	L	H	S	M	P	R	D	S	Q
RV20-10S	4.68	2.75	1.87	0.70	1.77	1.96	0.21	0.19	0.72
RV20-12S	5.00	2.44	1.98	0.76	1.88	2.16	0.25	0.27	0.64

DIRECT ACTING - PRINCE

BAILEY PART NO	MODEL CODE	PORT SIZE	MAX PSI	MAX GPM	PSI RANGE	WEIGHT (LBS)	
222852	RD-1850-S	1/2 NPT	2500	16	1000 - 2500	2.0	
222850	RD-1850-H			20			
222876	RD-1875-S	3/4 NPT		20	1000 - 2500		2.0
222875	RD-1875-H						

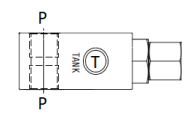

PILOT OPERATED - PRINCE

BAILEY PART NO	MODEL CODE	PORT SIZE	MAX PSI	MAX GPM	PSI RANGE	WEIGHT (LBS)
222790	RV-4L	1/2 NPT	3000	30	500 - 1500	3.0
222787	RV-4H				1500 - 3000	
222785	RV-2L	3/4 NPT			500 - 1500	
222786	RV-2H				1500 - 3000	
	RV-1L	SAE-12			500 - 1500	
222784	RV-1H				1500 - 3000	

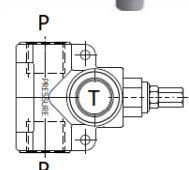

DIRECT ACTING

- LIMIT PRESSURE IN THE SYSTEM
- FAST ACTING
- MANY OTHER MODELS AVAILABLE

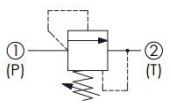

PILOT OPERATED

- LIMIT PRESSURE IN THE SYSTEM
- SMOOTH AND STABLE
- MANY OTHER MODELS AVAILABLE

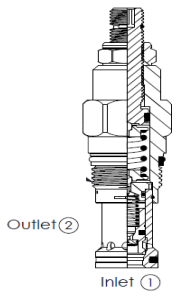

MODEL CODE	MAX GPM	MAX PSI	PSI RANGE	CAVITY
DE-RVA-00-1500	8	4000	200 - 1500	C10-2
DE-RVA-00-3000			1500 - 3000	
DE-RWA-00-3000			100 - 3000	
DE-RCA-00-3500	12	3500	250 - 3500	
RD10A-25-B-L	25	5000	300 - 1500	T-10A
RD10A-25-A-L			500 - 3000	
RD10A-25-C-L			1000 - 6000	
RD3A-25-B-L	50	5000	300 - 1500	T-3A
RD3A-25-A-L			500 - 3000	
RD3A-25-C-L			1000 - 6000	
RD16A-25-B-L	100	5000	250 - 3500	T-16A
RD16A-25-A-L			500 - 3000	
RD16A-25-C-L			1000 - 6000	

MODEL CODE	MAX GPM	MAX PSI	PSI RANGE	CAVITY
DE-RVP-00-4000	20	4000	1000 - 4000	C10-2
RP10W-25-B-L	25	5000	50 - 1500	
RP10W-25-A-L			100 - 3000	
RP10W-25-C-L			150 - 6000	
RP10A-20-B-L	50	5000	50 - 1500	T-10A
RP10A-20-A-L			100 - 3000	
RP10A-20-C-L			150 - 6000	
RP3A-20-B-L	50	5000	50 - 1500	T-3A
RP3A-20-A-L			100 - 3000	
RP3A-20-C-L			150 - 6000	
RP16A-20-B-L	100	5000	50 - 1500	T-16A
RP16A-20-A-L			100 - 3000	
RP16A-20-C-L			150 - 6000	

LINE MOUNT BODIES

- MATERIAL: ANODIZED ALUMINUM
- 3000 PSI MAXIMUM PRESSURE
- MANY OTHER MODELS AVAILABLE

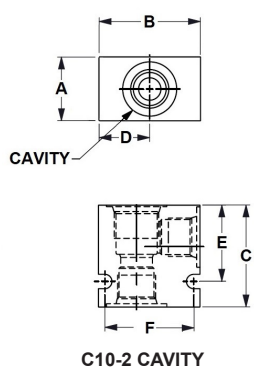

C10-2 CAVITY

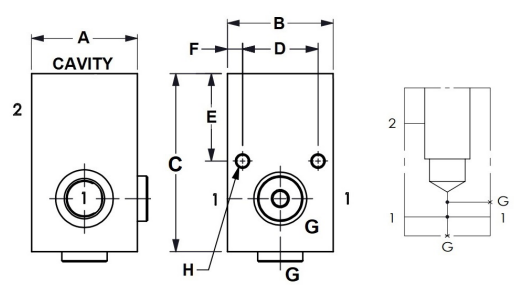

T-* CAVITIES



MODEL CODE	CAVITY	PORT SIZE	DIMENSIONS (IN)							
			A	B	C	D	E	F	G	H (2)
30102364	C10-2	SAE-06	2.12	2.0	1.50	1.75	0.50	-	-	0.28
30102359		SAE-08								
ML-10A2-S08G-A02	T-10A	SAE-08	1.75	1.75	2.94	1.25	2.06	0.25	1/4 NPT	1/4-20 UNC 1/2" DEEP
ML-10A2-S10G-A02		SAE-10								
ML-3A2-S10G-A02	T-3A	SAE-10	2.0	2.0	3.25	1.25	1.37	0.25		
ML-3A2-S12G-A02		SAE-12								
ML-16A2-S12G-A02	T-16A	SAE-12	3.0	3.0	4.5	2.25	2.11	0.37		

PRESSURE CONTROLS

FUNCTION	MODEL CODE	MAX GPM	MAX PSI	PSI RANGE	CAVITY	SCHEMATIC
VENTED RELIEF	RV11A-30-A-L	15	5000	100 - 3000	T11-A	
	RV2A-30-A-L	30			T2-A	
	RV17A-30-A-L	60			T-17A	
	RV19A-30-A-L	120			T-19A	
PRESSURE REDUCING	PB11A-30-A-L	10	5000	100 - 3000	T11-A	
	PB2A-30-A-L	20			T2-A	
	PB17A-30-A-L	40			T-17A	
	PB19A-30-A-L	80			T-19A	
PRESSURE REDUCING/RELIEVING	DF-PRP-00-3000	10	3000	100 - 3000	C10-3	
	SK-PRP-00-3000	20		500 - 3000	C16-3	
	PP11A-30-A-L	10	5000	100 - 3000	T11-A	
	PP2A-30-A-L	20			T2-A	
	PP17A-30-A-L	40			T-17A	
	PP19A-30-A-L	80			T-19A	
SEQUENCE	SP11A-30-A-L	15	5000	100 - 3000	T11-A	
	SP2A-30-A-L	30			T2-A	
	SP17A-30-A-L	60			T-17A	
	SP19A-30-A-L	120			T-19A	
UNLOADING	DF-PWE-00-0425	10	3000	50-425	C10-3	
	DF-PWE-00-1500			425-1500		



VALVES

LINE MOUNT BODIES

- MATERIAL: ANODIZED ALUMINUM
- 3000 PSI MAXIMUM PRESSURE
- MANY OTHER MODELS AVAILABLE

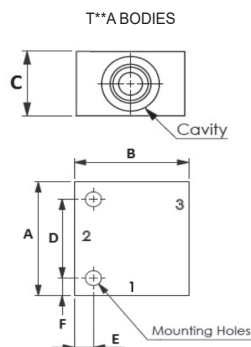
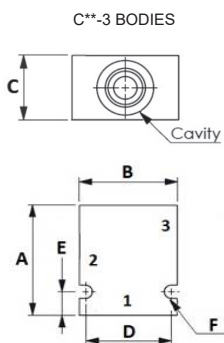

MODEL CODE	CAVITY	PORTS 1 & 2	PORT 3	DIMENSIONS (IN)						
				A	B	C	D	E	F	HOLES (2)
30102354	C10-3	SAE-08	SAE-08	2.50	2.50	1.50	2.25	0.38	0.28	-
30102576	C16-3	SAE-12	SAE-12	4.00	4.00	2.00	3.38	0.88	-	0.38
ML-11A3-S08-A01	T-11A	SAE-08	SAE-06	3.00	2.75	1.26	2.09	0.38	0.44	0.34
ML-2A3-S12A-A01	T-2A	SAE-12	SAE-06	3.25	3.00	1.50	2.25	0.50	0.50	0.42
ML-17A3-S16-A01	T-17A	SAE-16	SAE-06	4.25	4.00	2.36	2.75	0.75	0.75	
ML-19A3-S20G-A03	T-19A	SAE-20	SAE-06	5.00	5.00	3.00	4.00	0.50	0.50	
ML-19A3-S16-A01	T-19A	SAE-16	SAE-16							

FLOW CONTROLS

• MATERIAL: ZINC PLATED STEEL BODY

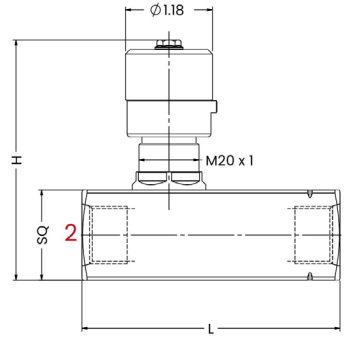
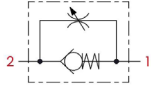

BAILEY PART NO	MODEL CODE	PORT SIZE	MAX PSI	MAX GPM	DIMENSIONS (IN)			WEIGHT (LBS)
					L	H	SQ	
450700	FC-04N	1/4 NPT	5800	6.6	2.63	2.99	0.98	0.88
450702	FC-06N	3/8 NPT	5800	9.3	3.03	2.99	0.98	0.88
450704	FC-08N	1/2 NPT	5800	13.2	3.38	3.19	1.18	1.32
450701	FC-06S	SAE-06	5800	6.6	2.77	2.99	0.98	0.88
450703	FC-08S	SAE-08	5800	9.3	3.38	3.19	1.18	0.88

PRESSURE COMPENSATED FLOW CONTROLS

• MATERIAL: ZINC PLATED STEEL BODY

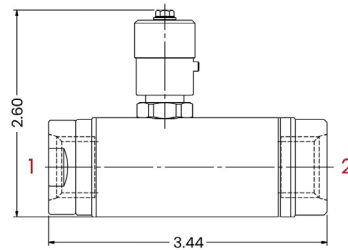
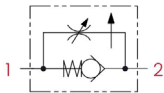

BAILEY PART NO	MODEL CODE	PORT SIZE	MAX PSI	MAX GPM	DIMENSIONS (IN)		WEIGHT (LBS)
					L	H	
450707	FCC-06S	SAE-06	3625	6.6	3.44	2.60	1.10
450708	FCC-08S	SAE-08	3625	7.9	3.44	2.60	1.10

NEEDLE VALVES

• MATERIAL: ZINC PLATED STEEL BODY

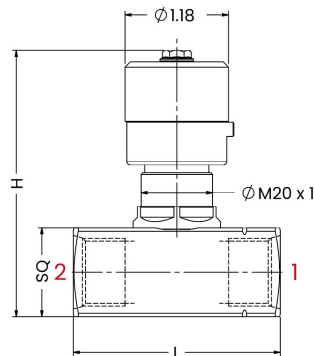
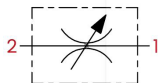

BAILEY PART NO	MODEL CODE	PORT SIZE	MAX PSI	MAX GPM	DIMENSIONS (IN)			WEIGHT (LBS)
					L	H	SQ	
450709	NV-04N	1/4 NPT	5800	6.6	2.13	2.99	0.98	0.66
450711	NV-06N	3/8 NPT	5800	9.3	2.13	2.99	0.98	0.66
450712	NV-08N	1/2 NPT	5800	13.2	2.28	3.19	1.18	0.98
450710	NV-06S	SAE-06	5800	6.6	2.13	2.99	0.98	0.66

3 WAY PRIORITY VALVE - LEVER TYPE

- PRESSURE COMPENSATED
- SEND EXCESS FLOW TO TANK

BAILEY PART NO	MODEL CODE	PORT SIZE	MAX PSI	MAX GPM	CONTROL FLOW (GPM)
252452	W-1950-16	1/2 NPT	3000	30	0 - 16
252455	WR-1950-16 *				
252454	W-1975-30	3/4 NPT			0 - 30
252456	WR-1975-30 *				
252453	W-1912-30	SAE-12			0 - 30
252457	WR-1912-30 *				

* MODEL WITH RELIEF

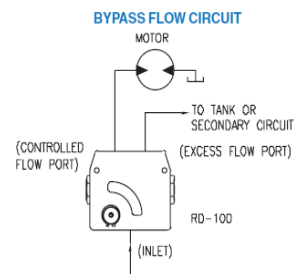

SIDE PORTED

BAILEY PART NO	MODEL CODE	PORT SIZE	MAX PSI	MAX GPM	CONTROL FLOW (GPM)
222199	RD-1950-8	1/2 NPT	3000	30	0 - 8
222455	RDRS-1950-8*				
	RDRS-1908-8	SAE-08			
222198	RD-1950-16	1/2 NPT			0 - 16
	RDRS-1950-16 *				
222204	RD-1975-30	3/4 NPT			0 - 30
222460	RDRS-1975-30 *				
222210	RD-1912-30	SAE-12			

* MODEL WITH RELIEF

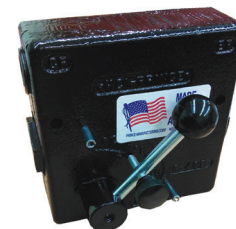

TOP PORTED

BAILEY PART NO	MODEL CODE	PORT SIZE	MAX PSI	MAX GPM	CONTROL FLOW (GPM)
222200	RD-150-8	1/2 NPT	3000	30	0 - 8
222175	RD-175-30	3/4 NPT			0 - 30



3 WAY PRIORITY VALVE - KNOB TYPE

- 3000 PSI MAXIMUM PRESSURE
- PRESSURE COMPENSATE
- SEND EXCESS FLOW TO TANK

MODEL CODE	PORT SIZE	MAX GPM	
		INLET	CONTROL FLOW
PVET-02	SAE-08	10.5	0 - 6.5
PVET-04	SAE-12	39	0 - 23.5

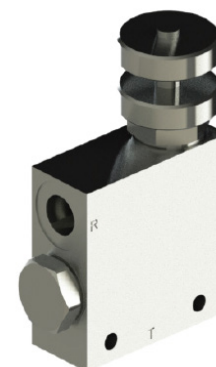
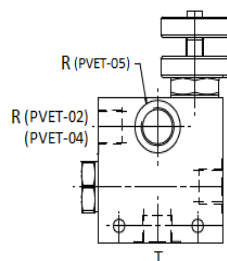

FLOW CONTROLS CARTRIDGE TYPE

MODEL CODE	MAX GPM	MAX PSI	CAVITY
NC13A-21BCL	6	5000	T-13A
DE-FCH-00	12	3500	C10-2
NC5A-21BCL	12	5000	T-5A
NC16A-21BCL	31		T-16A
NC18A-21BCL	50		T-18A

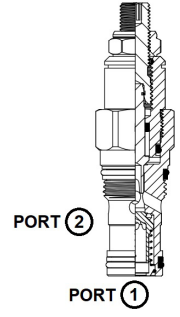
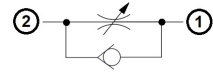

NEEDLE VALVE - CARTRIDGE TYPE

MODEL CODE	MAX GPM	MAX PSI	CAVITY
NV162A-2S40L	4	5000	T-162A
NV13A-2048L	6		T-13A
NV08W-20NL	10		C8-2
DE-NVA-00	10	3500	C10-2
DE-NVB-00	15		
NV5A-2063L	12.5	5000	T-5A
NV16A-2097L	25		T-16A
HT-NVA-00	36		C12-2
NV16A-28175L	90		T-16A

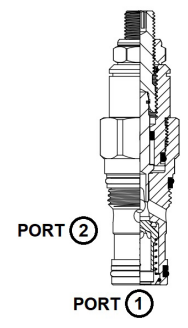
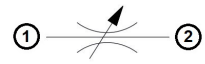

FLOW CONTROLS - PRESSURE COMPENSATED

MODEL CODE	MAX GPM	MAX PSI	FLOW RANGE (GPM)	CAVITY
FR13A-20AL	6	5000	0.1-5.5	T-13A
FR5A-20AL	25		0.1-11	T-5A
FR16A-20AL	39		0.2-24	T-16A
FR18A-20AL	79		0.2-50	T-18A

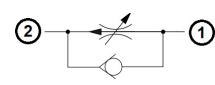

GO TO PAGE 134 FOR BODIES

3 WAY PRIORITY VALVE - CARTRIDGE TYPE

- PRESSURE COMPENSATED
- SEND EXCESS FLOW TO TANK
- KNOB AVAILABLE
- OTHER MODELS AVAILABLE

MODEL CODE	MAX GPM	MAX PSI	CONTROL FLOW (GPM)	CAVITY
FR10W-33NB	15	3500	0-10	C10-3
SK-FCQ-00-0025	25	3000	1-25	C16-3
FR17A-3A1000L	39	5000	0-26	T-17A
FR19A-3A2000L	79		0.2-53	T-19A

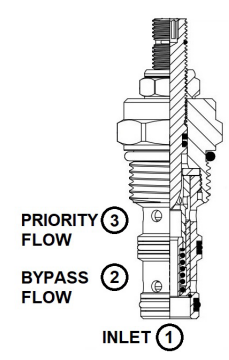
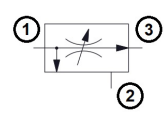

GO TO PAGE 129 FOR BODIES

- SUPERIOR QUALITY
- ISO & SUN CAVITIES
- 100% TESTED
- HEAT TREATMENT AND PLATING IN HOUSE

- ALL VALVES ARE ZINC-NICKEL PLATED. PROVIDES PROTECTION OF OVER 1000 HOURS BASED ON ASTM B117 SALT SPRAY TEST COMPARE TO 24 HOURS COMMON ZINC PLATING



SUN	WINNER	SUN	WINNER	SUN	WINNER	SUN	WINNER
CBCA-LHN	CB11A33HL	COJA-XCN	CO19A3020N	NFCC-LCN	NV13A2S48L	RDJA-LWN	RD18A20AW
CBCA-LIN	CB11A33IL	CSAA-EXN	LS13A20NS04	NFCD-KFN	NV13A2884K	RPCC-LAN	RP162A20AL
CBCG-LJN	CB11A34JL	CSAB-XXN	LS11A33NN	NFCD-LFN	NV13A2884L	RPCC-LWN	RP162A20AW
CBCG-LKN	CB11A34KL	CSAC-EXN	LS13A22NS04	NFDC-KAN	NV5A2S63K	RPEC-8DN	RP10A20D8
CBCH-LJN	CB11A30JL	CSAD-XXN	LS11A30NN	NFDC-LAN	NV5A2S63L	RPEC-8WN	RP10A20W8
CBCH-LKN	CB11A30KL	CSAW-EXN	LS162A20NS04	NFDD-KGN	NV5A28127K	RPEC-LAN	RP10A20AL
CBEA-LHN	CB2A33HL	CSAX-XXN	LS163A33NN	NFDD-LGN	NV5A28127L	RPEC-LWN	RP10A20AW
CBEA-LIN	CB2A33IL	CSAY-EXN	LS162A22NS04	NFEC-KEN	NV16A2S97K	RPGC-8DN	RP3A20D8
CBEG-LJN	CB2A34JL	CSAZ-XXN	LS163A30NN	NFEC-LEN	NV16A2S97L	RPGC-8WN	RP3A20W8
CBEG-LKN	CB2A34KL	CXAD-XCN	CV162A2120	NFED-KHN	NV16A28175K	RPGC-LAN	RP3A20AL
CBEH-LJN	CB2A30JL	CXBA-XAN	CV162A2003	NFED-LHN	NV16A28175L	RPGC-LWN	RP3A20AW
CBEH-LKN	CB2A30KL	CXBA-XCN	CV162A2020	NFFD-KIN	NV16A29216K	RPIC-8DN	RP16A20D8
CBGA-LHN	CB17A33HL	CXCD-XCN	CV13A2120	NFFD-LIN	NV16A29216L	RPIC-8WN	RP16A20W8
CBGA-LIN	CB17A33IL	CXDA-XAN	CV13A2003	PBDB-8DN	PP11A30D8	RPIC-LAN	RP16A20AL
CBGG-LJN	CB17A34JL	CXDA-XCN	CV13A2020	PBDB-8WN	PP11A30W8	RPIC-LWN	RP16A20AW
CBGG-LKN	CB17A34KL	CXED-XCN	CV5A2120	PBDB-LAN	PB11A30AL	RPKC-8DN	RP18A20D8
CBGH-LJN	CB17A30JL	CXFA-XAN	CV5A2003	PBDB-LWN	PB11A30WL	RPKC-8WN	RP18A20W8
CBGH-LKN	CB17A30KL	CXFA-XCN	CV5A2020	PBFB-8DN	PP2A30D8	RPKC-LAN	RP18A20AL
CBIA-LHN	CB19A33HL	CXGD-XCN	CV16A2120	PBFB-8WN	PP2A30W8	RPKC-LWN	RP18A20AW
CBIA-LIN	CB19A33IL	CXHA-XAN	CV16A2003	PBFB-LAN	PB2A30AL	RSDC-8DN	RV11A30D8
CBIG-LJN	CB19A34KL	CXHA-XCN	CV16A2020	PBFB-LWN	PB2A30WL	RSDC-8WN	RV11A30W8
CBIG-LKN	CB19A34JL	CXID-XCN	CV18A2120	PBHB-8DN	PP17A30D8	RSDC-LAN	SP11A30AL
CBIH-LJN	CB19A30KL	CXJA-XAN	CV18A2003	PBHB-8WN	PP17A30W8	RSDC-LWN	SP11A30WL
CBIH-LKN	CB19A30JL	CXJA-XCN	CV18A2020	PBHB-LAN	PB17A30AL	RSFC-8DN	RV2A30D8
CKBB-XCN	CO163A3020N	FDBA-KAN	FR13A20AK	PBHB-LWN	PB17A30WL	RSFC-8WN	RV2A30W8
CKBD-XCN	CO163A3C20N	FDBA-LAN	FR13A20AL	PBJB-8DN	PP19A30D8	RSFC-LAN	SP2A30AL
CKCB-XAN	CO11A3003N	FDCB-KAN	FR5A20AK	PBJB-8WN	PP19A30W8	RSFC-LWN	SP2A30WL
CKCB-XCN	CO11A3020N	FDCB-LAN	FR5A20AL	PBJB-LAN	PB19A30AL	RSHC-8DN	RV17A30D8
CKCD-XAN	CO11A3C03N	FDEA-KAN	FR16A20AK	PBJB-LWN	PB19A30WL	RSHC-8WN	RV17A30W8
CKCD-XCN	CO11A3C20N	FDEA-LAN	FR16A20AL	PPDB-LAN	PP11A30AL	RSHC-LAN	SP17A30AL
CKEB-XAN	CO2A3003N	FDFA-KAN	FR18A20AK	PPDB-LWN	PP11A30WL	RSHC-LWN	SP17A30WL
CKEB-XCN	CO2A3020N	FDFA-LAN	FR18A20AL	PPFB-LAN	PP2A30AL	RSJC-8DN	RV19A30D8
CKED-XAN	CO2A3C03N	FXCA-XAN*	FR13A2F****N	PPFB-LWN	PP2A30WL	RSJC-8WN	RV19A30W8
CKED-XCN	CO2A3C20N	FXDA-XAN*	FR5A2F****N	PPHB-LAN	PP17A30AL	RSJC-LAN	SP19A30AL
CKGB-XAN	CO17A3003N	NCCB-LCN	NC162A21BCL	PPHB-LWN	PP17A30WL	RSJC-LWN	SP19A30WL
CKGB-XCN	CO17A3020N	NCCB-KCN	NC13A21BCK	PPJB-LAN	PP19A30AL	SCCA-LAN	SC11A30AL
CKGD-XAN	CO17A3C03N	NCCB-LCN	NC13A21BCL	PPJB-LWN	PP19A30WL	SCCA-LWN	SC11A30WL
CKGD-XCN	CO17A3C20N	NCEB-KCN	NC5A21BCK	RDBA-LAN	RD162A20AL	SCEA-LAN	SC2A30AL
CKIB-XAN	CO19A3003N	NCEB-LCN	NC5A21BCL	RDBA-LWN	RD162A20AW	SCEA-LWN	SC2A30WL
CKIB-XCN	CO19A3020N	NCFB-KCN	NC16A21BCK	RDDA-LAN	RD10A20AL	SCGA-LAN	SC17A30AL
CKID-XAN	CO19A3C03N	NCFB-LCN	NC16A21BCL	RDDA-LWN	RD10A20AW	SCGA-LWN	SC17A30WL
CKID-XCN	CO19A3C20N	NCGB-KCN	NC18A21BCK	RDFA-LAN	RD3A20AL	SCIA-LAN	SC19A30AL
COBA-XCN	CC163A3020N	NCGB-LCN	NC18A21BCL	RDFA-LWN	RD3A20AW	SCIA-LWN	SC19A30WL
CODA-XCN	CC11A3020N	NFBC-KCN	NV162A2S40K	RDHA-LAN	RD16A20AL		
COFA-XCN	CO2A3020N	NFBC-LCN	NV162A2S40L	RDHA-LWN	RD16A20AW		
COHA-XCN	CO17A3003N	NFCC-KCN	NV13A2S48K	RDJA-LAN	RD18A20AL		

LINE MOUNT BODIES

- MATERIAL: ANODIZED ALUMINUM
- 3000 PSI MAXIMUM PRESSURE
- MANY OTHER MODELS AVAILABLE

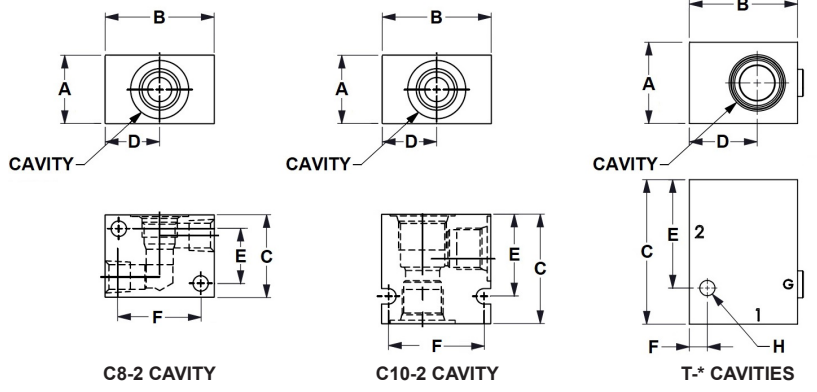

MODEL CODE	CAVITY	PORT SIZE	DIMENSIONS (IN)							
			A	B	C	D	E	F	G	H
30102466	C8-2	SAE-06	1.25	2.00	2.00	1.13	1.50	1.50	-	0.28
30102364	C10-2	SAE-06	1.50	2.00	2.00	1.25	1.50	1.75	-	0.28
30102359		SAE-08							-	
ML-162A2-S06-A01	T-162A	SAE-06	1.00	1.50	2.00	1.00	1.72	0.28	-	0.28
ML-13A2-S06-A01	T-13A	SAE-06	1.25	1.63	2.19	1.00	1.91	0.28	-	0.34
ML-5A2-S08-A01	T-5A	SAE 08	1.50	2.0	2.63	1.50	2.25	0.38		0.42
ML-5A2-S10-A01		SAE-10								
ML-16A2-S12G-A01	T-16A	SAE-12	2.25	3.0	4.00	1.88	3.00	0.50	1/4 NPT	0.42
ML-16A2-S16G-A01		SAE 16								

PRESSURE COMPENSATED FLOW DIVIDERS

- DIVIDER / COMBINER
- 3000 PSI MAXIMUM PRESSURE
- PRECISE AT +/- 10% ACCURACY
- COMMON CAVITIES

MODEL CODE	INLET FLOW (GPM)	PORT SIZE
DG-FDA-00-50-03	2-3	SAE-08 (USE BODY 30102362)
DG-FDA-00-50-06	3-6	
DG-FDA-00-50-09	6-9	
DG-FDA-00-50-12	9-12	
SN-FDA-00-50-15	8-15	SAE-12 (USE BODY 30102577)
SN-FDA-00-50-25	15-25	
SN-FDA-00-50-40	20-40	

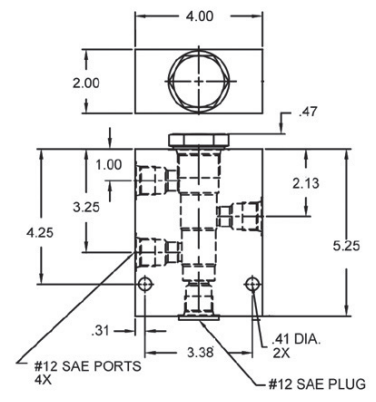
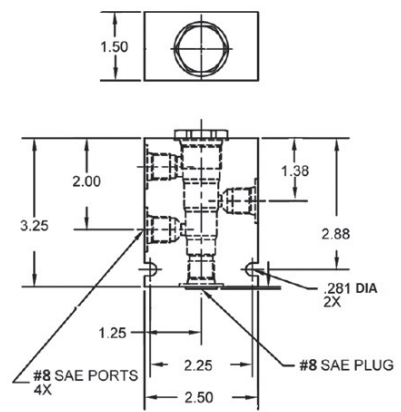
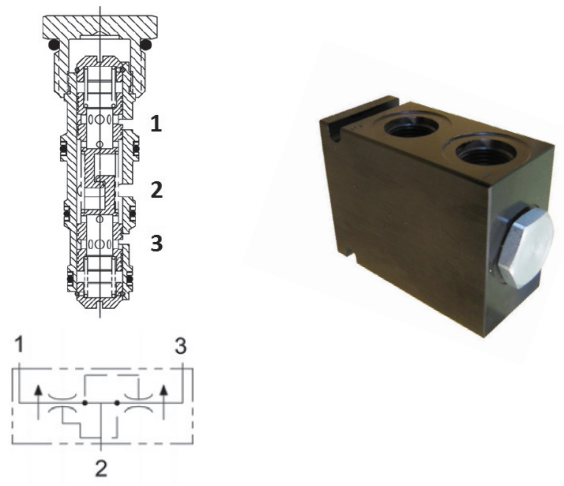

VIVOIL DIVIDERS

- SPLIT FLOW EQUALLY WITH +/- 1,5% ACCURACY
- INTEGRATED RELIEFS TO REALIGN CYLINDERS WHEN THEY REACH END OF CYCLE
- FOR A QUIET OPERATION, SELECT SPEED AT REC FLOW

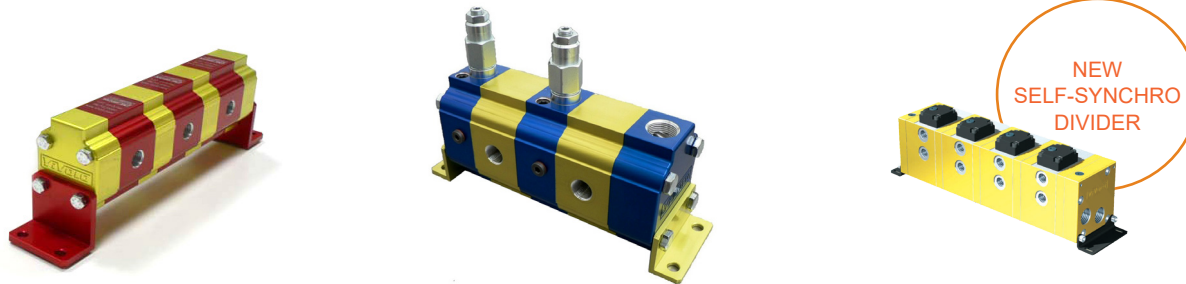

MODEL CODE	NUMBER OF SECTIONS	DISPLACEMENT IN ³ / REV.	RPM		GPM		MAX PSI	PORT SIZE	
			MIN	MAX	MIN	MAX		IN	OUT
ARV02B01	2	0.01	1155	7392	0.10	0.64	3045	SAE-4	SAE-4
ARV02B06	2	0.05	1200	5867	0.53	1.27	3045	SAE-8	SAE-6
ARV02B20	2	0.13	1175	6095	1.3	6.9	3190		
ARV02B27	2	0.26	1060	5400	2.4	12.2	3190		
ARV02B34	2	0.48	1082	4520	4.5	18.0	3045		
ARV02B43	2	0.37	1200	2500	3.8	7.9	3000	SAE-12	SAE-10
ARV02B49	2	0.85	1200	2500	8.9	18.5	2600		
ARV02B55	2	1.34	1200	2500	13.9	29.0	2600		
ARV04B20	4	0.13	1175	6095	2.6	13.7	3190	SAE-8	SAE-6
ARV04B27	4	0.26	1060	5400	4.7	24.3	3190		

DELTA POWER DIVIDERS

- SPLIT FLOW EQUALLY WITH +/- 2% ACCURACY
- INTEGRATED RELIEFS TO REALIGN CYLINDERS WHEN THEY REACH END OF CYCLE
- FOR A QUIET OPERATION, SELECT SPEED AT RECOMMENDED FLOW
- CAN BE USE INTERNAL OR EXTERNAL DRAIN
- AVAILABLE FROM 2 TO 16 SECTIONS



MODEL CODE	NUMBER OF SECTIONS	DISPLACEMENT IN ³ / REV.	RPM		GPM		MAX PSI	PORT SIZE	
			MIN	MAX	MIN	MAX		IN	OUT
PM2-RV **	2	0.11	500	3500	0.5	3.5	2000	1/2 NPT	3/8 NPT
PM6-RV **	2	0.32			1.35	9.5	1500		
HPR23	2	0.70			3.0	21	3000		
HPR27	2	1.46			6.3	44	3000	SAE-16	SAE-12
PPM2-RV **	4	0.11			1.0	7.0	1500	1/2 NPT	3/8 NPT
HPR21-59	4	0.41			3.57	25	3000	SAE-16	SAE-12
HPR23-59	4	0.70	6	42	3000				

** MODELS AVAILABLE WITHOUT RELIEF

ASA MODELS

- DIAPHRAGM TYPE
- REPAIRABLE
- P1620 VALVE ON TOP

MODEL CODE	VOLUME (LITERS)	MAX PSI	PORT SIZE	DIMENSIONS (IN)	
				A	C
AS0.2 NE1W	0.2	5880	1/4 BSPP	5.9	3.3
AS0.5 NE1W	0.5		3/8 BSPP	7.2	4.5
AS0.7 NE1W	0.7	3675		M18X1.5	7.8
AS1 NE1W	1.0	5880	6.4		

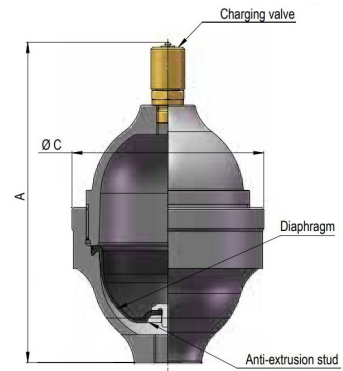

ACSA & ACSL MODELS

- ECONOMICAL
- NON-REPAIRABLE
- BLADDER TYPE

MODEL CODE	VOLUME (LITER)	MAX PSI	PORT SIZE	VALVE	DIM "A" (IN)
ACSL0.7 S15VN	0.7	3000	SAE-08	SCREW	6.9
ACS0.7 S15YP		4800		SCHRADER	
ACSL1 S15VN	1.0	3000	SAE-08	SCREW	9.7
ACS1 S15YP		4800		SCHRADER	
ACS1.5 S15VN	1.5	4800	SAE-08	SCREW	12.4
ACS1.5 S15YP				SCHRADER	
ACS2.5 S15VN	2.5	4800	SAE-08	SCREW	18.3
ACS2.5 S16YP			SAE-12	SCHRADER	
ACS4 S16VN	4.0	4800	SAE-12	SCREW	27.4
ACS4 S16YP				SCHRADER	

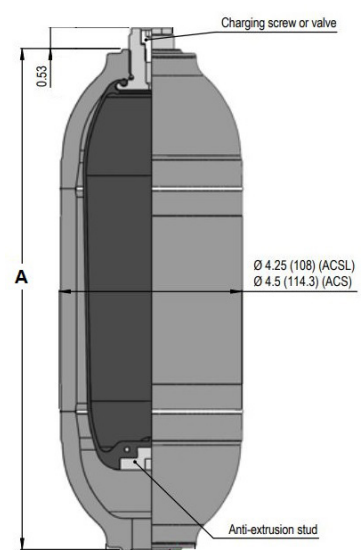

ABVE MODELS

- BLADDER TYPE
- REPAIRABLE

MODEL CODE	VOLUME (LITER)	MAX PSI	PORT SIZE	VALVE	DIMENSIONS (IN)	
					A	C
ABVE4 S2G4WN	4	5145	1 1/4" BSPP	P1620	17.2	6.7
ABVE10 S2G5WN	10	4800	2" BSPP		22.8	9.0
ABVE20 S2G5WN	20	4800			34.6	
ABVE32 S2G5WN	32				55.1	
ABVE50 S0G5WN	50				75.4	

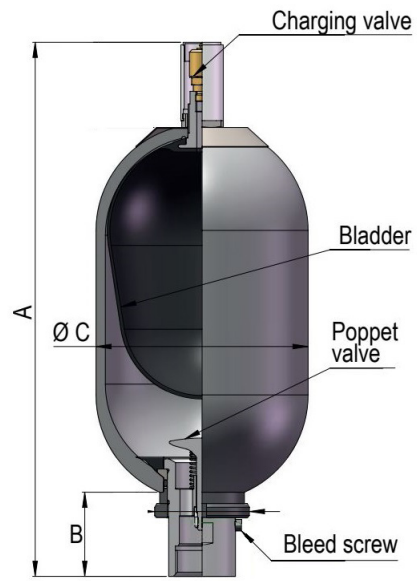

FIXATION CLAMPS

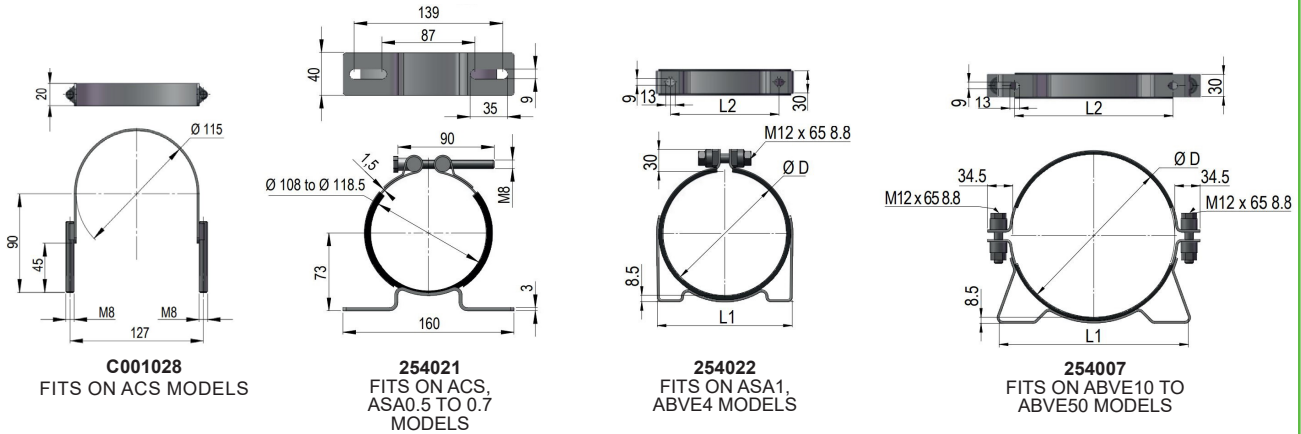

FIXATION SEATS

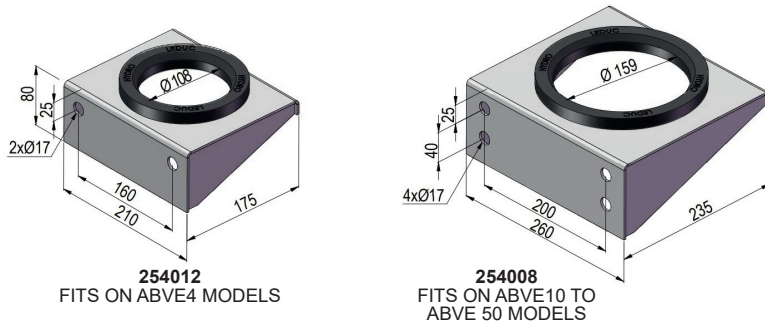

PISTON ACCUMULATORS

- 3000 PSI MAXIMUM WORKING PRESSURE
- DESIGNED FOR MOBILE APPLICATION
- REACT FAST
- LONG SERVICE LIFE
- REPAIRABLE
- COMPACT DESIGN
- COMMON SHRADER VALVE

MODEL CODE	VOLUME (IN ³)	DIM "A"
AC-0006-3	6	6.50
AC-0024-3	24	12.25
AC-0052-3	52	21.25

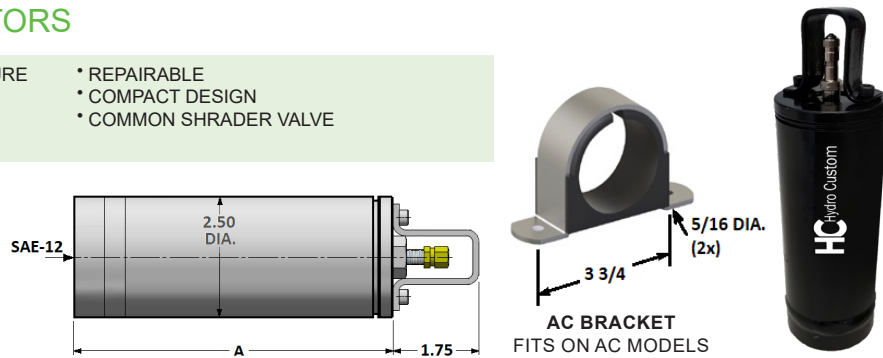

CHARGING KITS



066650 COMPLETE KIT
- ADAPTS TO MOST OF VALVE
- INCLUDES HOSE



066660 CHARGING KIT
ADAPTS TO MOST OF VALVES



701630 (NO GAUGE)
FITS ON SCHRADER VALVES ONLY



704230 HOSE KIT
FOR 701630

PRESSURE SWITCHES

- 9000 PSI MAXIMUM PRESSURE
- FIELD ADJUSTABLE
- +/- 2% REPEATABILITY
- 1/4 NPT CONNECTION
- UP TO 3A / 125 VAC SUPPLY
- N.O. OR N.C. CIRCUIT
- DIN CONNECTOR TYPE

MODEL CODE	PSI RANGE	PSI DIFFERENTIAL
BPA-1-4M-C-HC	5 - 85	3 - 10
BPA-1A-4M-C-HC	65 - 300	8 - 30
BPA-3-4M-C-HC	300 - 2500	50 - 300
BPA-4-4M-C-HC	1000 - 6000	150 - 600
BPA-5-4M-C-HC	500 - 3500	75 - 300

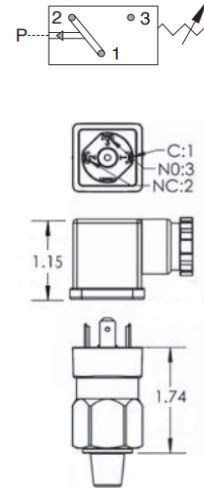

VACUUM SWITCH

- 9000 PSI MAXIMUM PRESSURE
 - FIELD ADJUSTABLE
 - +/- 2% REPEATABILITY
 - 1/4 NPT CONNECTION
 - UP TO 3A / 125 VAC SUPPLY
 - N.O. OR N.C. CIRCUIT
 - DIN CONNECTOR TYPE
 - 5-85 IN HG RANGE
- MODEL CODE: BPA-1-4M-C-HC**

PRESSURE TRANSDUCERS

- 8700 PSI MAXIMUM PRESSURE
- 4 - 20 MA SIGNAL OUTPUT (2 WIRE)
- 1/4 NPT CONNECTION
- +/- 0.5% REPEATABILITY

INFORMATION ABOUT THE TDD MODEL WITH LCD DISPLAY

- DISPLAY IN REALTIME
- CAN BE SET IN DIFFERENT UNITS: KPA, MPA, BAR, PSI
- PROVIDE ADJUSTMENT TO ZERO AND SPAN CALIBRATION

MODEL CODE	PSI RANGE	VOLTAGE SUPPLY	CONNECTOR
XTC-A-0/3000-4M-HCM-81	0 - 3000	12-30 VDC	MINI DIN 43650C
XTC-A-0/6000-4M-HCM-81	0 - 6000		
TDD-A-0/3000-4M-M	0 - 3000	18-30 VDC	M12 - 3 PINS C/W 79" CABLE
TDD-A-0/6000-4M-M	0 - 6000		



TDD MODEL WITH LCD DISPLAY

ALSO AVAILABLE

- DIFFERENT PORTS AND ADJUSTMENT RANGE
- OTHER OUTPUT SIGNALS & TYPE OF ELECTRICAL CONNECTORS
- FACTORY SET ADJUSTEMENT
- MANY OTHER MODELS FOR SPECIFIC APPLICATIONS
- DIFFERENTIAL PRESSURE SWITCH
- TEMPERATURE SWITCH & TRANSDUCER



PRESSURE GAUGES

- 2 1/2" & 4" ROUND FACE
- GLYCERIN FILLED
- 1/4 NPT CONNECTION ON THE 2 1/2" FACE
- 1/2 NPT CONNECTION ON THE 4" FACE

MODEL CODE

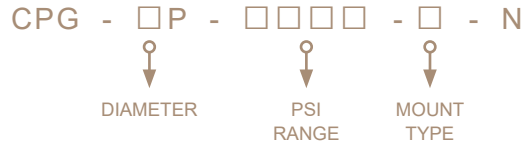

GAUGE DIAMETER	
INCHES	CODE
2 1/2"	1
4"	2

PRESSURE RANGE	
PSI RANGE	CODE
0 - 600	600
0 - 1000	1000
0 - 2000	2000
0 - 3000	3000
0 - 5000	5000
0 - 6000	6000
0 - 10000	10K

MOUNT TYPE	
TYPE	CODE
BOTTOM STEM	A
BACK STEM	D



STEM MOUNT



CENTER BACKMOUNT

BACKMOUNT FLANGE

MODEL CODE	GAUGE DIAMETER
CPMB - 1 P	2 1/2"
CPMB - 2P	4"



DIGITAL PRESSURE GAUGES

	HYDRO CUSTOM	STAUFF
DISPLAY MEASURED VALUES (MIN & MAX)	√	√
RUBBER PROTECTIVE COVERING		√
UNITS: BAR, PSI, MPA, KPA	√	√
RESET BUTTON	√	√
BACKGROUND LIGHTNING	√	√
ACCURACY OR 0.5% OF FULL SCALE	√	√
SAE 04 CONNECTION		√
NPT 1/4 CONNECTION	√	
WIRELESS AVAILABLE	√	√



CDPG-IP5000A-N
0-5000 PSI

CDPG-IP12KA-N
0-12000 PSI



SPG-DIGI-B0400-U
0-5800 PSI

BAYONET FILLER BREATHERS

- ZINC PLATED CAP
- 160 GPM MAXIMUM FLOW

MODEL CODE	DESCRIPTION
57XL10	10 MICRONS
57XL40	40 MICRONS
LC 57XL40	LOCKING CAP, 40 MICRONS
57XL40-3HN	3" HIGH NECK, 40 MICRONS
57XL40-P5	PRESSURIZED 5 PSI, 40 MICRONS
LC 57XL40-P5	LOCKING CAP, PRESSURIZED 5 PSI, 40 MICRONS
AS 57XL40	ANTI-SPLASH, 40 MICRONS
AS 57XL40-P5	ANTI SPLASH, 40 MICRONS, PRESSURIZED 5 PSI

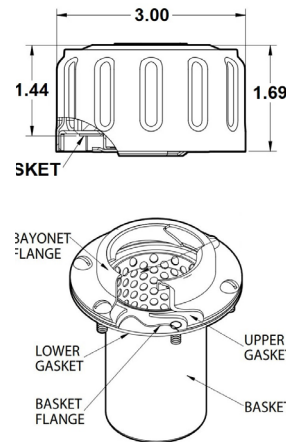

BAYONET, PVC FILLER BREATHER

- ANTI-SPLASH
- 10 MICRONS
- 380 GPM MAXIMUM FLOW

MODEL CODE: ATP0PLSCAR0LI20



NYLON THREADED BREATHERS

- 40 MICRONS (10 MICRONS AVAILABLE)
- OTHER OPTIONS AVAILABLE

MODEL CODE	THREAD	OPTIONS	DIMENSIONS (IN)			
			A	B	C	D
NY-4	1/4 NPT		1.2			
NY-6	3/8 NPT			1.4	0.8	0.6
NY-8	1/2 NPT		1.6			
AS-NY-8		ANTI-SPLASH				
NY-12	3/4 NPT		1.8	1.5	0.9	0.6
AS-NY-12		ANTI-SPLASH				
NY-7-12			2.8	2	1.4	0.7
AS-NY-7-12		ANTI-SPLASH				
NY-7-20	1 1/4 NPT		2.8			
AS-NY-7-20		ANTI-SPLASH				
AS-NY-7-20-DIP5"		ANTI-SPLASH + DIPSTICK 5"	2.8	2.2	1.4	0.8

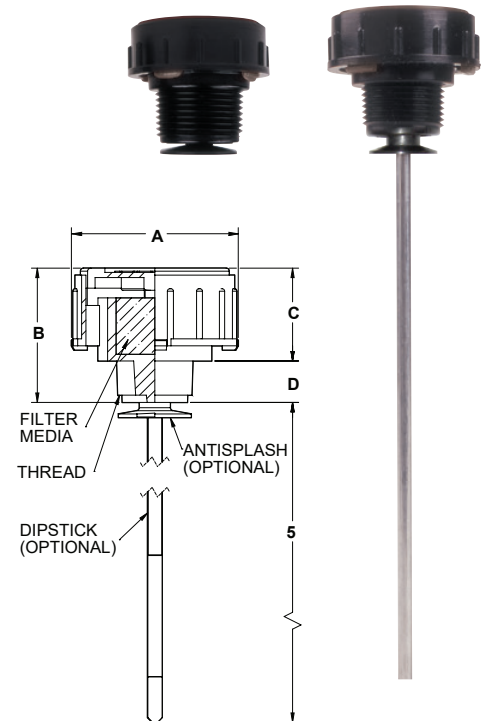

METAL THREADED BREATHERS

- ZINC PLATED CAP
- 40 MICRONS (10 MICRONS AVAILABLE)

MODEL CODE	THREAD	DIMENSIONS (IN)		
		A	B	C
BF-4	1/4 NPT	1.4	1.9	0.7
BF-6	3/8 NPT			
BF-8	1/2 NPT	2.6	2.9	0.9
BF-12	3/4 NPT	2.6	3.0	1.1
BF-12-16				
BF-12-16-P5				
BF-16	1" NPT	3.0	3.3	1.4

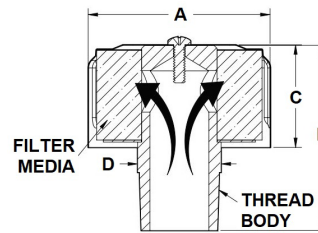

PUSH ON BREATHERS

- 40 MICRONS
- CLIPS ON A 1.5" TUBE

MODEL CODE: NYPO-24



WELD-ON BREATHERS

- 40 MICRONS
- 2.38" TUBE TO WELD ON TANK

MODEL CODE: FB-18



SPIN-ON BREATHERS

- 10 MICRONS PAPER (MANY OPTIONS AVAILABLE)

MODEL CODE	THREAD	MAX CFM	SPARE ELEMENT	ADAPTOR ONLY
LGB-12-10	3/4 NPT	150	CP-752-10	LABA-12
LGB-20-10	1 1/4 NPT	250	CP-1282-10	LABA-20
LGB-B-310	BAYONET	40	CP-AB-310	B12



DESICCANT BREATHERS

- 2 MICRONS RATING
- ABSORB WATER VAPOR
- SILICA GEL TURNS FROM GOLD TO GREEN WHEN MAXIMUM ABSORPTION IS REACHED

MODEL CODE	MAX GPM	MAX H2O CAPACITY
DB-03	262	100 ML
DB-05		200 ML
DB-08		425 ML



Threaded Adapter

Bayonet Adapter

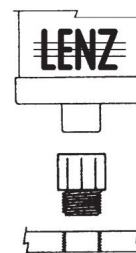

DESICCANT BREATHER ADAPTORS

- ADAPT DESICCANT BREATHER TO TANK

MODEL CODE	DESCRIPTION
DB-BA	BAYONET
DB-R2	3/4" NPT

LEVEL GAUGES

- OIL INDICATOR WITH THERMOMETER
- AVAILABLE WITH METRIC BOLT THREAD

MODEL CODE	THREAD	DIMENSIONS (IN)		
		I	H1	H2
T-LLG-3	1/2-13 UNC	3.0	4.2	1.2
T-LLG-5		5.0	6.1	
T-LLG-10		10.0	11.1	1.3

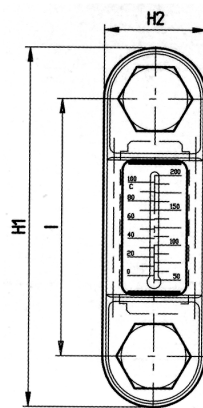

SIGHT WINDOWS

- INDICATE LIQUID LEVEL IN RESERVOIR
- REFLECTOR BALL IN OPTION

MODEL CODE	THREAD	MODEL CODE	THREAD
LSW-6	3/8 NPT	LSW-16	1" NPT
LSW-8	1/2 NPT	LSW-16RB*	1" NPT
LSW-A8	SAE-08	LSW-20	1 1/4 NPT
LSD-8	1/2 BSP	LSW-24	1 1/2 NPT
LSW-12	3/4 NPT	LSW-32	2" NPT

* REFLECTOR BALL



MODEL WITH REFLECTOR

TANK COVERS

- GIVES ACCESS TO INSIDE OF RESERVOIR
- MADE IN STEEL ZINC PLATED
- NO-LEAK GASKET
- DRAIN IN OPTION

MODEL CODE	DIM "A" (IN)
TC-6	6.0
TC-12	12.0
TC-14	14.0

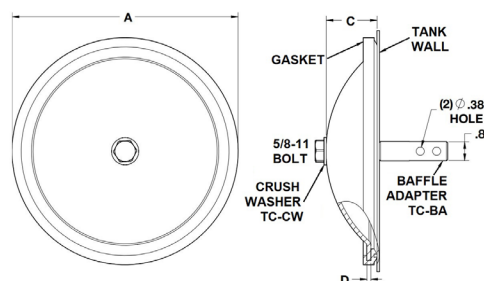

BAFFLE ADAPTER

- LINKS THE TANK COVER TO THE BAFFLE

MODEL CODE: TC-BA

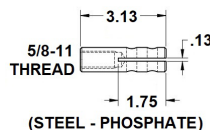

MAGNETIC DRAIN PLUGS

- ATTRACTS FERROUS PARTICLES

MODEL CODE	THREAD
MDP-8	1/2 NPT
MDP-12	3/4 NPT
MDP-16	1 NPT

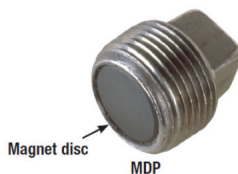

ALSO AVAILABLE



ELECTRIC MOTORS

MOTOR FRAME	PUMP FLANGE	FACE TO FACE	MODEL CODE
56-145TC	4F17 - 1.781" - 4 BOLT	4.25"	B564F42
	SAE AA - 2" - 2 BOLT	3.50"	B56AA35
		4.25"	B56AA42
	SAE A - 3 1/4" - 2 BOLT	3.50"	B56A35
4.25"		B56A42	
5.00"		B182A50	
182-256TC	SAE A - 3 1/4" - 2 BOLT	5.81"	B182A58
		6.81"	B182A68
		5.81"	B182B58
	SAE B - 4" - 2 BOLT	6.81"	B182B68
		6.87"	B284B68
284-286TC	SAE B - 4" - 2 1/4 BOLT	6.87"	B284B68
		7.87"	B284B78

TECHNICAL INFORMATION ON ELECTRICAL MOTORS

HP	FRAME	SHAFT DIMENSIONS			TORQUE (LB-IN)			
		DIA.	KEY	LENGTH				
1	143TC	7/8	3/16	2.25"	35			
1.5	145TC				52			
2					70			
3	182TC	1 1/8	1/4	2.75"	105			
5	184TC				175			
7.5	213TC	1 3/8	5/16	3.38"	262			
10	215TC				350			
15	254TC				1 5/8	3/8	4.00"	525
20	256TC	700						
25	284TC	1 7/8	1/2	4.63"				875
30	286TC							

BASED ON TEFC MOTORS @ 1800 RPM

COUPLINGS

COUPLING SIZE	MAXIMUM BORE	RATED TORQUE (LBF.IN)			DIMENSIONS (IN)			
		SPIDER MATERIAL			OD	OAL	G	LTB
		NITRILE	URETHANE	HYTREL				
L075	7/8	90	135	227	1.75	2.13	0.50	0.82
L095	1 1/8	194	291	561	2.11	2.51	0.52	1.00
L100	1 3/8	417	626	1137	2.54	3.48	0.71	1.38
L110	1 5/8	792	1188	2268	3.32	4.22	0.88	1.68
L150	1 7/8	1240	1660	3708	3.75	4.50	1.00	1.75

COUPLING MODEL CODES

L075-1/2	L095-1/2	L100-1/2		
L075-5/8	L095-5/8	L100-5/8	L110-5/8	L150-5/8
L075-3/4	L095-3/4	L100-3/4	L110-3/4	L150-3/4
L075-7/8	L095-7/8	L100-7/8	L110-7/8	L150-7/8
	L095-1	L100-1	L110-1	L150-1
	L095-1 1/8	L100-1 1/8	L110-1 1/8	L150-1 1/8
		L100 1 3/8	L110-1 3/8	L150-1 3/8
			L110-1 5/8	L150-1 5/8
				L150-1 7/8

INSERT MODEL CODES

SPIDER MATERIAL		
NITRILE	URETHANE	HYTREL
L075N	L075U	L075H
L095N	L095U	L095H
L100N	L100U	L100H
L110N	L110U	L110H
L150N	L150U	L150H

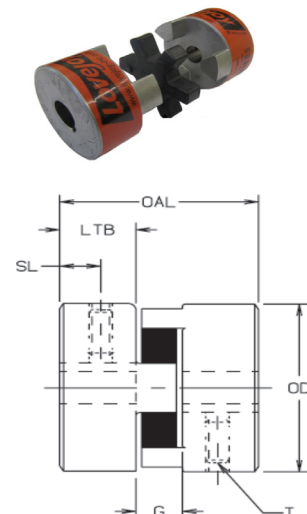

GAS ENGINES

HP	PUMP FLANGE	FACE TO FACE	MODEL CODE	
5.5 & 6.5	4F17 - 1.781" 4 BOLT	4.63"	ADAP55-175	
	SAE-AA - 2" 2 BOLT	4.63"	ADAP55-200	
8 TO 20	4F17 - 1.781" 4 BOLT	5.50"	ADAP90200-175B	
		6.0"	ADAP90200-L-175	
	SAE-AA - 2" 2 BOLT	5.50"	ADAP90200-200	
		SAE-A 3 1/4" - 2 BOLT	5.50"	ADAP90200-C-325
			6.00"	ADAP90200-L-325

TECHNICAL INFORMATION ON GAS ENGINE MOTORS

HP	SHAFT DIMENSIONS (IN)			TORQUE (LB-IN)
	DIAMETER	KEY	LENGTH	
5.5	3/4	3/16	2.42	100
6.5				118
8	1	1/4	3.48	146
9				164
11				200
13				237

BASED ON STD GAS ENGINE @ 3540 RPM

PUMPS

TECHNICAL INFORMATION ON PUMP SHAFTS

SHAFT TYPE	DIAMETER	LENGTH
SAE-AA 4 BOLT	1/2	1.50"
SAE-AA 2 BOLT	1/2	1.06"
SAE-A	5/8	1.25"
SAE-A	3/4	1.25"
SAE-B	7/8	1.61"
SAE-BB	1	1.81"

SPIN-ON FILTERS

- CELLULOSE MEDIA FILTER
- OTHER MICRONS AND MEDIA AVAILABLE

PLEASE ADD "T" AFTER MODEL CODE TO INSTALL THE CLOGGING INDICATOR (NOT INCLUDED)

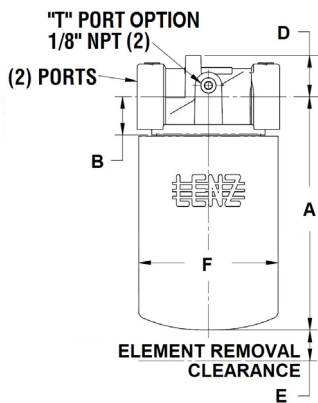

MODEL CODE	PORT SIZE	MAX PSI	MAX GPM	MICRONS	SPARE ELEMENT	POST THREAD	BYPASS PSI	DIMENSIONS (IN)					
								A	B	D	E	F	
CP-380-1018	3/8 NPT	200	5	10	CP-1018	3/4-16 UNF	18	3.9	0.7	0.6	0.4	3.1	
CP-380-4018				40	CP-4018								
CPA-380-1018				10	CP-1018								
CP-750-10P	3/4 NPT	200	15	10	CP-752-10	1"-12 UNF	15	6.2	1.0	1.1	0.8	3.7	
CPA-750-10P	SAE-12												
CP-750-30P	3/4 NPT	200	15	25	CP-752-30	1"-12 UNF	15	9.6	1.0	1.1	0.8	3.7	
CP-750-100MP			100 MESH	CP-752-100M									
CPL-750-10P			10	CPL-752-10									
CP-1280-10P	1 1/4 NPT	150	60	10	CP-1282-10-50	1 1/2-16 UNF	15	8.1	1.5	1.2	1.2	5.0	
CPA-1280-10P	SAE-20												
CP-1280-25P	1 1/4 NPT	150	60	25	CP-1282-25-50	1 1/2-16 UNF	15	12.2	1.5	1.2	1.2	5.0	
CP-1280-100MP				100 MESH	CP-1282-100M								
CPL-1280-10P				10	CPL-1282-10								

DUAL SPIN-ON FILTERS

- MAXIMUM WORKING PRESSURE: 150 PSI
- BYPASS VALVE 25 PS
- 1 1/2 NPT PORTS
- SAE PORTS AVAILABLE

FILTER HEAD AND ELEMENTS MUST BE ORDERED SEPARATELY



FILTER HEADS



FILTER ELEMENTS (REQUIRES 2 PCS)

MODEL CODE	MAX GPM	MEDIA
CP-1282-10-50	56	10 MICRONS CELLULOSE
CP-1282-25-50		25 MICRONS CELLULOSE
CPL-1282-10-50	72	10 MICRONS CELLULOSE
CPL-1282-10-50		25 MICRONS CELLULOSE

OTHER ELEMENTS AVAILABLE ON REQUEST

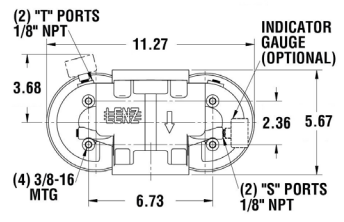
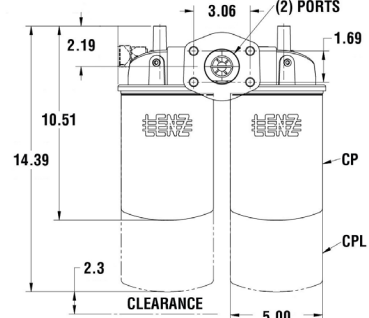

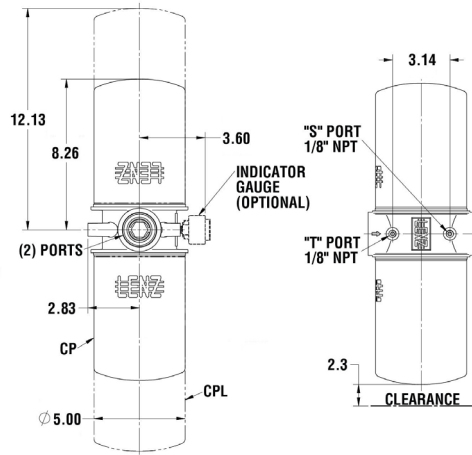
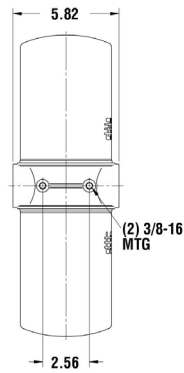

MEDIUM PRESSURE FILTERS

- 350 PSI MAXIMUM WORKING PRESSURE
- BYPASS VALVE 25 PSI
- OTHER MICRONS AND MEDIA AVAILABLE

MODEL CODE	PORT SIZE	MAX GPM	MEDIA	SPARE ELEMENT
DH-750-800RR	3/4 NPT	18	10 MICRONS CELLULOSE	8-03
DH-750-400RR		32	30 MICRONS CELLULOSE	4-03
DH-750-100		35	100 WIRE MESH	5062-100
DH-1250-800RR	1 1/4 NPT	52	10 MICRONS CELLULOSE	8-15
DH-1250-400RR		63	30 MICRONS CELLULOSE	4-15
DH-1500-800RR	1 1/2 NPT	52	10 MICRONS CELLULOSE	8-15
DH-1500-400RR		63	30 MICRONS CELLULOSE	4-15



DH-750 MODELS

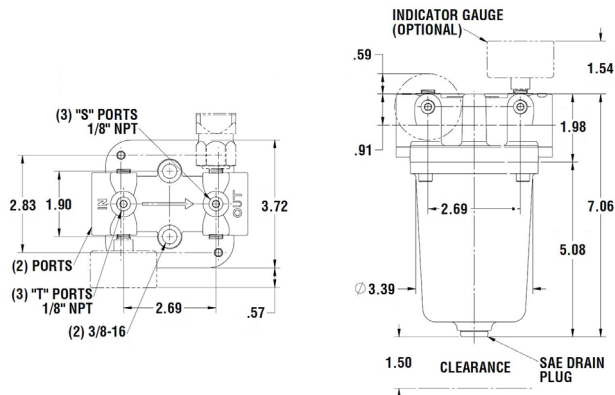

DH-1250 MODELS

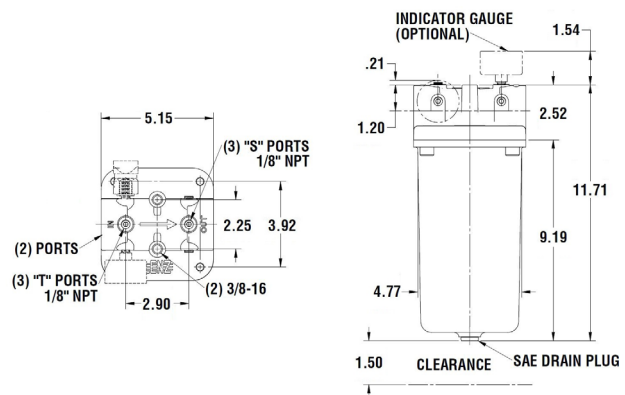

CLOGGING INDICATORS



MC-12
RETURN LINE INDICATING GAUGE FOR 15 PSI FILTER APPLICATIONS
2" MULTICOLOR
0-12 PSI GREEN
12-15 PSI YELLOW
15-60 PSI RED (SERVICE FILTER)



MC-20
RETURN LINE INDICATING GAUGE FOR 25 PSI FILTER APPLICATIONS
2" MULTICOLOR
0-20 PSI GREEN
21-24 PSI YELLOW
25-60 PSI RED (SERVICE FILTER)



PMA-1-2M-A-SP
ELECTRICAL SWITCH
ADJUSTMENT RANGE: 2-25 PSI
N.O. SIGNAL
SINGLE SPADE

LENZ TANK MOUNT FILTERS

- MAXIMUM PRESSURE: 100 PSI
- BY-PASS VALVE 25 PSI
- OTHER MICRONS AND MEDIA AVAILABLE

MODEL CODE	PORT SIZE	MAX GPM*	MEDIA	SPARE ELEMENT	BOLT PATTERN
LIT-750-10P	3/4 NPT	24	10 MICRONS CELLULOSE	LIT-752-10P	115 MM
LIT-750-25P			25 MICRONS CELLULOSE	LIT-752-10P	
LIT-750-10SYN	3/4 NPT	16	10 MICRONS SYNTHETIC	LIT-752-10SYN	
LITA-750-10SYN	SAE-12			LIT-752-10SYN	
LIT-1250-10P	1 1/4 NPT	55	10 MICRONS CELLULOSE	LIT-1252-10P	175 MM
LIT-1250-25P			25 MICRONS CELLULOSE	LIT-1252-25P	
LIT-1250-10SYN			10 MICRONS SYNTHETIC	LIT-1252-10SYN	
LITA-1250-10P	SAE-20	55	10 MICRONS CELLULOSE	LIT-1252-10P	
LITA-1250-25P			25 MICRONS CELLULOSE	LIT-1252-25P	
LITA-1250-10SYN			10 MICRONS SYNTHETIC	LIT-1252-10SYN	

*CALCULATED WITH MAX 7.25 PSI DELTA P (FILTER HOUSING + ELEMENT) @ 30 CST VISCOSITY



UFI TANK MOUNT FILTERS

- 43 PSI MAXIMUM WORKING PRESSURE
- BY-PASS VALVE 24 PSI
- OTHER MICRONS AND MEDIA AVAILABLE

MODEL CODE	PORT SIZE	MAX GPM*	MEDIA	SPARE ELEMENT	BOLT PATTERN
FRA31N04BNCC01WX	1/2 NPT	12	10 MICRONS CELLULOSE	ERA31NCC	115 MM
FRA31N04BNCD01WX			25 MICRONS CELLULOSE	ERA31NCD	
FRA31N04BNFC01WX		11	12 MICRONS SYNTHETIC	ERA31NFC	
FRA31S04BNCC01WX	SAE-08	12	10 MICRONS CELLULOSE	ERA31NCC	
FRA31S04BNCD01WX			25 MICRONS CELLULOSE	ERA31NCD	
FRA31S04BNFC01WX		11	12 MICRONS SYNTHETIC	ERA31NFC	
FRA32N06BNCC01WX	3/4 NPT	31.5	10 MICRONS CELLULOSE	ERA32NCC	115 MM
FRA32N06BNCD01WX		39	25 MICRONS CELLULOSE	ERA32NCD	
FRA32N06BNFC01WX		18.5	12 MICRONS SYNTHETIC	ERA32NFC	
FRA32S06BNCC01WX	SAE-12	31.5	10 MICRONS CELLULOSE	ERA32NCC	
FRA32S06BNCD01WX		39	25 MICRONS CELLULOSE	ERA32NCD	
FRA32S06BNFC01WX		18.5	12 MICRONS SYNTHETIC	ERA32NFC	
FRA32N08BNFD01WX	1" NPT	29.5	21 MICRONS SYNTHETIC	ERA32NFD	175 MM
FRA41N10BNCC01WX	1 1/4 NPT	71	10 MICRONS CELLULOSE	ERA41NCC	
FRA41N10BNCD01WX		78	25 MICRONS CELLULOSE	ERA41NCD	
FRA41N10BNFC01WX		50	12 MICRONS SYNTHETIC	ERA41NFC	
FRA41N10BNFD01WX		66	21 MICRONS SYNTHETIC	ERA41NFD	
FRA41N10BNME01WX		78	60 WIRE MESH	ERA41NME	
FRA41S10BNCC01WX		SAE-20	71	10 MICRONS CELLULOSE	ERA41NCC
FRA41S10BNCD01WX	78		25 MICRONS CELLULOSE	ERA41NCD	
FRA41S10BNFC01WX	50		12 MICRONS SYNTHETIC	ERA41NFC	

*CALCULATED WITH MAX 7.25 PSI DELTA P (FILTER HOUSING + ELEMENT) @ 30 CST VISCOSITY



RETURN FILTERS FOR PADOAN TANKS

- MICROFIBER ELEMENTS (60* MICRONS IS WIRE MESH)
- BY-PASS VALVE 24 PSI
- OTHER MICRONS AND MEDIA AVAILABLE

MF135 FLANGE (FOR 8-13 GALLONS RESERVOIRS)

MODEL CODE	PORT SIZE	MAX PSI	MAX GPM*	MICRONS	SPARE ELEMENT	BOLT PATTERN
AFO0IMM134103F2	1" NPT MALE	43	33	21	AFO0ELF142070F2	115 MM
AFO0IMM134103ST			40	60*	AFO0ELF142070RM	
AFO0SEM135101F2	1" NPT	116	33	21	AFO0ELF13007025	
AFO0SEM135101ST			40	60*	AFO0ELF128070BF	



AFO0IMM MODELS

MF135 FLANGE (FOR 18+ GALLONS RESERVOIRS)

MODEL CODE	PORT SIZE	MAX PSI	MAX GPM*	MICRONS	SPARE ELEMENT	BOLT PATTERN
AFO0IMM134102F1	1" NPT MALE	43	39	10	AFO0ELF205070F1	115 MM
AFO0IMM134102F2			48	21	AFO0ELF205070F2	
AFO0IMM134102ST			58	60	AFO0ELF13007025	
AFO0SEM137125F1	1 1/4 NPT	116	39	10	AFO0ELF205070F1	
AFO0SEM137125F2			53	21	AFO0ELF205070F2	
AFO0SEM137125RM			66	60*	AFO0ELF205070RM	



AFO0SEM MODELS

MF195 FLANGE

MODEL CODE	PORT SIZE	MAX PSI	MAX GPM*	MICRONS	SPARE ELEMENT	BOLT PATTERN
AFO0SEM196125F1	1 1/4 NPT	116	53	10	AFO0ELF211099F1	175 MM
AFO0SEM196125F2			66	21	AFO0ELF211099F2	
AFO0SEM196125CL			79	60*	AFO0ELF210100RM	

*CALCULATED WITH MAX 7.25 PSI DELTA P (FILTER HOUSING + ELEMENT) @ 30 CST VISCOSITY

PADOAN EASY KITS FOR TIPPING VALVES

- 43 PSI MAXIMUM WORKING PRESSURE
- BY-PASS VALVE 24 PSI
- 135 MM BOLT PATTERN
- OTHER MICRONS AND MEDIAS AVAILABLE

MODEL CODE	MAX GPM*	MICRONS	SPARE ELEMENT
AKV0VDS0MF250CF	60	40	AFO0ELF205070CF

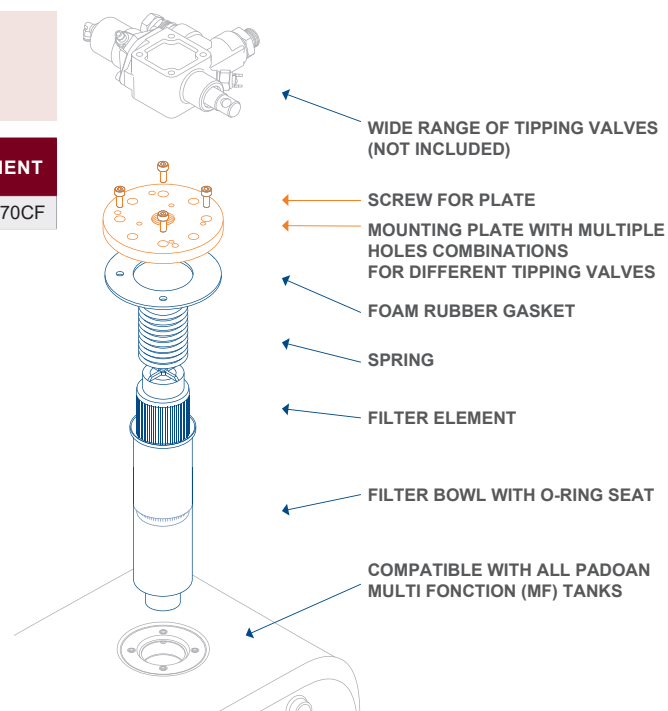

PRESSURE FILTERS

- BYPASS VALVE 87 PSI
- VISUAL CLOGGING INDICATOR 72.5 PSI
- FIBERGLASS MEDIA ELEMENTS, BETA 1000 (99.9% EFFICIENCY)
- OTHER CHOICES OF ELEMENTS AVAILABLE



MODEL CODE	PORT SIZE (D1)	MAX GPM*	MAX PSI	MICRONS	SPARE ELEMENT
FPB13 S04 CNFC5EXX	SAE-08	15	6090	12	EPB13NFC
FPB13 S06 CNFC5EXX	SAE-12				EPB13NFC
FPB21 S06 CNFC5EXX	SAE-12	12	6090	12	EPB21NFC
FPB22 S06 CNFC5EXX	SAE-12	25			EPB22NFC
FPB31 S08 CNFC5EXX	SAE-16	35	6090	12	EPB31NFC
FPB31 S10 CNFC5EXX	SAE-20	12			EPB31NFC
FPB32 S10 CNFC5EXX	SAE-20	74			EPB32NFC
FPB35 G10 CNFA03XX	CF61-1 1/4	70	6090	5	EPB35NFA
FPB35 F12 CNFA03XX	CF61-1 1/2	85			EPB35NFA
FPC51 S06 CNFC5ECX	SAE-12	20	5510	12	EPC51NFC
FPC55 S08 CNFC5ECX	SAE-16	31			EPC55NFC

*CALCULATED WITH MAX 7.25 PSI DELTA P (FILTER HOUSING + ELEMENT) @ 30 CST VISCOSITY

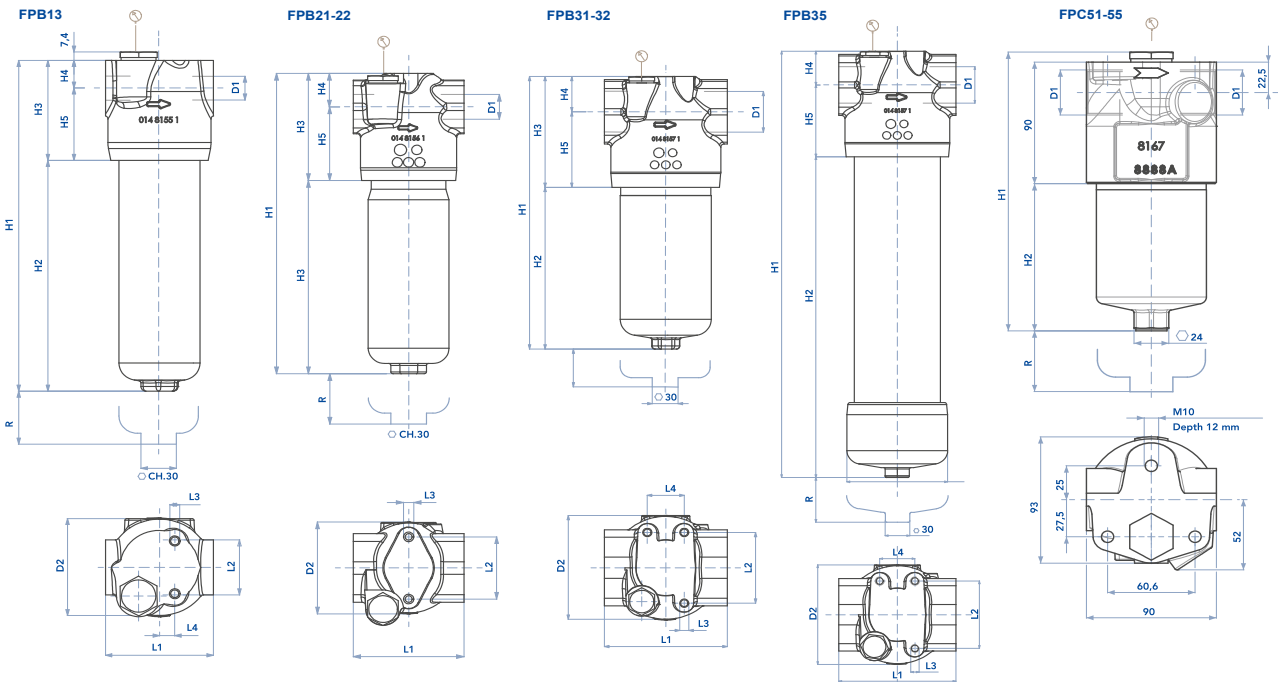

MODELS	DIMENSIONS (IN)											WEIGHT (LBS)
	D2	H1	H2	H3	H4	H5	L1	L2	L3	L4	R	
FPB13	3.39	11.65	8.23	3.43	0.95	2.48	3.46	1.81	M8	0.49	3.94	11.5
FPB21	3.70	8.90	4.57	4.41	1.38	3.03	4.25	2.56	M8	-	3.94	14.6
FPB22	3.70	12.48	8.15	4.41	1.38	3.03	4.25	2.56	M8	-	3.94	18.1
FPB31	5.04	9.65	4.21	5.43	1.73	3.70	5.63	3.46	M10	1.69	3.94	24.3
FPB32	5.04	13.27	7.83	5.43	1.73	3.70	5.63	3.46	M10	1.69	3.94	30.6
FPB35	5.04	25.91	20.47	5.43	1.73	3.70	5.63	3.46	M10	1.69	3.94	55.1
FPC51	-	8.15	4.29	-	-	-	-	-	-	-	-	9.3
FPC55	-	12.08	8.27	-	-	-	-	-	-	-	-	11.7

STRAINERS

- PLATED STEEL PIPE NUT
- 100 MESH STAINLESS STEEL WIRE CLOTH
- OPTIONAL BY-PASS VALVE AVAILABLE
- EASILY CLEANABLE AND REUSABLE
- GOOD FOR MANY TYPE OF FLUID

MODEL CODE	MAX GPM	PORT SIZE (A)	DIMENSIONS (INCHES)		
			B	C	D
49-3	3	3/8 NPT	1.2	2.5	1.9
49-4	5	1/2 NPT	1.9	3.1	2.6
49-5	8	3/4 NPT	2.9	3.6	2.6
49-10	10	1" NPT	4.6	5.4	2.6
49-20	20	1 1/4 NPT	6.1	6.9	3.0
49-30	30	1 1/2 NPT	7.2	8.0	3.3
49-50	50	1 1/2 NPT	9.1	9.9	3.9
49-50-2	50	2" NPT	9.1	9.9	3.9
49-75	75	2 1/2 NPT	9.1	10.1	5.1
49-100	100	3" NPT	10.4	11.8	5.1

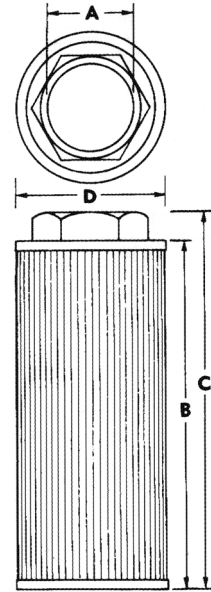

TANK MOUNT STRAINERS

- CAST IRON PIPE NUT
- 100 MESH STAINLESS STEEL WIRE CLOTH
- OPTIONAL BY-PASS VALVE AVAILABLE

MODEL CODE	MAX GPM	PORT SIZE		DIMENSIONS (IN)		
		A	B	C	D	E
LTM-3	3	3/4 NPT	3/8 NPT	4.0	1.0	0.9
LTM-5	5	1" NPT	1/2 NPT	5.4	1.1	1.2
LTM-10	10	1 1/4 NPT	3/4 NPT	8.2	1.2	1.4
LTM-15	15	1 1/2 NPT	1" NPT	8.2	1.2	1.7
LTM-25	25	2" NPT	1 1/4 NPT	9.0	1.4	2.1
LTM-50	50	3" NPT	2" NPT	9.7	1.7	3.0
LTM-100	100	4" NPT	3" NPT	11.3	1.8	4.0

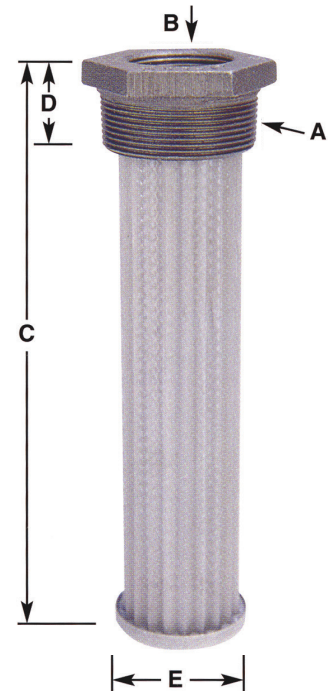

JIC TYPE

EACH STYLE T1 TANK INCLUDES:

- * OIL LEVEL & TEMP. GAUGE HOLES
- * FILLER BREATHER RISER
- * 2 STEEL END-COVERS WITH GASKETS
- * BAFFLE WITH CUTOUTS FOR CIRCULATION
- * 3/4" SAE DRAIN IN END COVER
- * EXTERIOR OF TANK PRIME PAINTED
- * INTERIOR OF TANK COATED WITH RUST REVENTIVE OIL

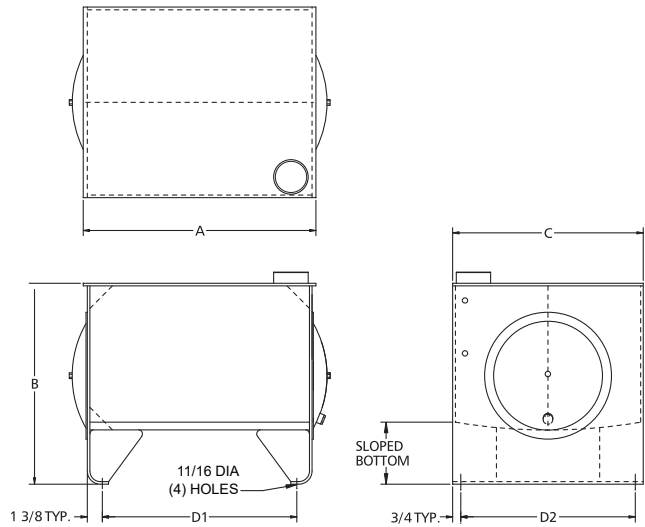

PART NUMBER	CAPACITY GALLONS	TANK DIMENSIONS (INCHES)						MATERIAL THICKNESS		WEIGHT LBS
		A LENGTH	B HEIGHT	C WIDTH	MOUNTING CENTERS		END COVER	END	TOP	
					D1±1/8	D2±1/8				
T1.15	15	26.0	19.38	18.0	22.25	16.5	12.0	7 GA	7 GA	105
T1.20	20	30.0	19.38	18.0	26.25	16.5	12.0	7 GA	7 GA	125
T1.30	30	36.0	19.38	24.0	32.25	22.5	12.0	7 GA	7 GA	178
T1.40	40	36.0	21.0	24.0	32.25	22.5	12.0	7 GA	7 GA	190
T1.50	50	36.0	23.0	24.0	32.25	22.5	16.0	7 GA	7 GA	200
T1.60	60	48.0	20.68	27.0	44.25	25.5	16.0	7 GA	3/8"	314
T1.80	80	60.0	21.5	27.0	56.25	25.5	16.0	7 GA	3/8"	398
T1.100	100	60.0	23.5	27.0	56.25	25.5	16.0	7 GA	3/8"	418

VERTICAL TANKS - IMMERSED PUMP INSTALLATION

TV TANK INCLUDES:

- * OIL LEVEL & TEMP. GAUGE MOUNTING HOLES
- * 4 COVER MOUNTING BOLTS
- * CHANNEL GASKET FOR COVER PLATE
- * 3/4" SAE DRAIN
- * OUTSIDE OF TANK PRIME PAINTED
- * INTERIOR OF TANK COATED WITH RUST PREVENTIVE OIL

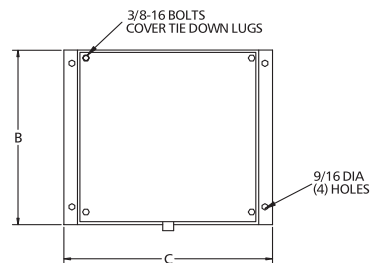

TOP COVER MUST BE ORDERED SEPARATELY

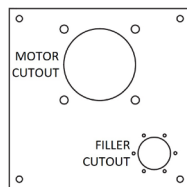

FITS BAYONET STYLE FILLER-BREATHER

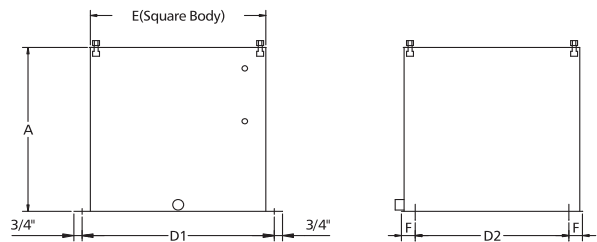

PART NUMBER	CAPACITY GALLONS	DIMENSIONS (IN)							WEIGHT LBS	TOP COVER		
		A	B	C	D1±1/8	D2±1/8	E	F		WITH FILLER CUTOUT	FILLER + 56/145TC CUTOUT	FILLER + 182/256TC CUTOUT
TV-173	10	15.5	17.5	20.0	18.75	15.0	17.0	1.25	65	TVL-934A	TVL-937A	TVL-943A
TV-174	20	18.5	18.0	20.5	19.25	15.0	17.5	1.5	80	TVL-949	TVL-952	TVL-955
TV-175	30	26.5	18.0	20.5	19.25	15.0	17.5	1.5	100			

our point of view

Download brochure

https://www.padoan.it/documents/NA/Padoan_NA_brochure.pdf
Standard and customized tanks

In this brochure Padoan presents the "N" tanks, the standard solutions available for our clients. Our R&D dept. is at your disposal to find the best solution to fit your needs with customized products.

Feel free to contact us at info@padoan.it.

Go to our online configurator to find the best solution for you

<https://www.padoan.it/en/north-america-configurator/>

Family company since 1937, we are **manufacturer of oil, diesel-oil and combined tanks/reservoirs** for industrial vehicles and machineries.

With a strong focus on R&D, technology and support to our clients, the mission is translated into action by the **Italian headquarter and by the 3 subsidiary companies** in Switzerland, Germany and Chile.

Our know-how allows us to provide the right **solution to bodybuilders, OEMs and distribution networks** too.

The **Italian design and quality markout our wide range of hydraulic tanks/reservoirs specifically designed for North America**.

Quality, innovation, r&d are keystones of our success in more than 50 Countries in the world.

Our mission and vision can be expressed by our claim: **WETANKYOU since 1937**.

We want to be a partner more than a supplier, working by our clients' side and reaching their goals, that is the reason why every day we ThANK our clients who trust us as a partner to develop their projects and strategies.

At the same time whe ThANK our team, more than 200 people in the world who, from more than 80 years, provides the quality and value we share with you.

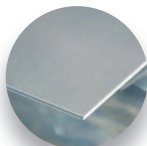
**RAW MATERIAL USED IN AUTOMOTIVE FIELD**

The material we use guarantees resistance, finishing, longer life expectancy, high quality perception to create premium products.

**AUTOMATIZED WELDING PROCESS**

For several years our welding process has been carried out by automatized robots, through the adoption of the MIG/MAG technology. This allows a better internal cleaning avoiding the contamination normally caused by manual or standard welding.

**PAINTING PROCESS WITH PRIMER TREATMENT**

The painted steel tanks are finished with an epoxy powder varnishing (from 110 to 180 μ) to guarantee the protection from aggressive agents. Primer is also applied for further protection. Each tank is also tested through a salt spray process lasting 500 hours.

**RELIABILITY TEST WITH CRACK TESTING MACHINE**

All of our tanks components, including brackets and straps, are tested with our cracking vibration machine to verify the life expectancy and quality of our products.

**QUALITY TEST 1:1 WITH LEAK DETECTOR**

Every tank is tested through an automatized machinery to verify any microscopic loss, using helium technology. Every tank is marked with a label to indicate it has been tested and approved.

All rights reserved to Padoan srl. It is not allowed any kind of copy or use of information or pictures contained in this brochure.

Pictures and descriptions provided for our products are not to scale and are intended for illustrative purposes only.

Padoan is not responsible for any mistake or inaccuracy. The Company reserves the right to change the technical features of the products without prior notice.

26/36 SERIE - SADDLEMOUNT INSTALLATION

- MADE OF STEEL
- WELDED MOUNTING BRACKET
- LEVEL GAUGE INCLUDED
- RETURN COVER FLANGE INCLUDED
- USE WITH COMMON BAYONET FILLER-BREATHER

FOR MORE DETAILS

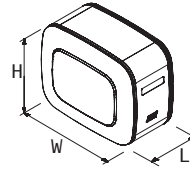

MODEL CODE	CAPACITY GALLONS	DIMENSIONS (IN)			SUCCION CONNECTION	RETURN FILTER BOLT PATTERN
		L	H	W		
NSOF0030036US00	8	14.4				
NSOF0050046US00	11	18.3	10.2	14.2	1 1/4 NPT	115 MM
NSOF0050056US00	13	22.3				

26/36 SERIE - UPRIGHT INSTALLATION

- MADE OF STEEL
- WELDED MOUNTING BRACKET
- LEVEL GAUGE INCLUDED
- RETURN COVER FLANGE INCLUDED
- USE WITH COMMON BAYONET FILLER-BREATHER

FOR MORE DETAILS

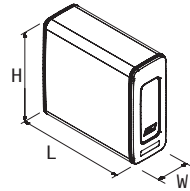

MODEL CODE	CAPACITY GALLONS	DIMENSIONS (IN)			SUCCION CONNECTION	RETURN FILTER BOLT PATTERN
		L	H	W		
NSOF0050046US01	11	18.3	14.2	10.2	1 1/4 NPT	115 MM
NSOF0050056US01	13	22.3				

44/54 SERIE - SADDLEMOUNT INSTALLATION

- MADE OF ALUMINUM
- LEVEL GAUGE INCLUDED
- RETURN COVER FLANGE INCLUDED
- USE WITH COMMON BAYONET FILLER-BREATHER

FOR MORE DETAILS

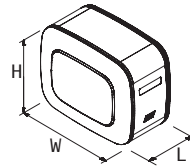

MODEL CODE	CAPACITY GALLONS	DIMENSIONS (IN)			SUCCION CONNECTION	RETURN CONNECTION	RETURN FILTER BOLT PATTERN
		L	H	W			
NSOA0070035US00	18	13.8	17.6	21.5	1 1/2 NPT	1 1/4 NPT	115 MM

50/64 SERIE

- SADDLEMOUNT OR UPRIGHT INSTALLATION
- LEVEL GAUGE INCLUDED
- RETURN COVER FLANGE INCLUDED
- USE WITH COMMON BAYONET FILLER-BREATHER

FOR MORE DETAILS

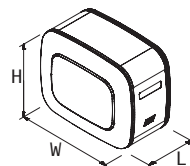

MODEL CODE	MATERIAL	CAPACITY GALLONS	DIMENSIONS (IN)			SUCCION CONNECTION	RETURN CONNECTION	RETURN FILTER BOLT PATTERN
			L	H	W			
NSOF0100040US00	STEEL	28	15.7	20.0	25.1	1 1/2 NPT	1 1/4 NPT	115 MM
NSOA0100040US00	ALUMINUM							
NSOF0120045US00	STEEL	32	17.7	20.0	25.1	1 1/2 NPT	1 1/4 NPT	115 MM
NSOA0120045US00	ALUMINUM							
NSOF0150055US00	STEEL	40	21.6	20.0	25.1	1 1/2 NPT	1 1/4 NPT	115 MM
NSOA0150055US00	ALUMINUM							

63/70 SERIE

- * SADDLEMOUNT OR UPRIGHT INSTALLATION
- * LEVEL GAUGE INCLUDED
- * RETURN COVER FLANGE INCLUDED
- * USE WITH COMMON BAYONET FILLER-BREATHER

FOR MORE DETAILS

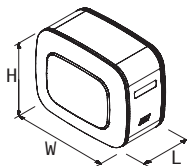

MODEL CODE	MATERIAL	CAPACITY GALLONS	DIMENSIONS (IN)			SUCCION CONNECTION	RETURN CONNECTION	RETURN FILTER BOLT PATTERN
			L	H	W			
NSOF0135035US00	STEEL	35	13.7	25.1	27.9	1 1/2 NPT	1 1/4 NPT	115 MM
NSOF0200050US00	STEEL	51	19.7					
NSOA0200050US00	ALUMINUM	80	28.9					
NSOA0300073US00	ALUMINUM	106	39.4			2" NPT	2" NPT	175 MM

BRACKETS - SADDLEMOUNT

- * STAINLESS STEEL STRAPS

MODEL CODE	SERIE
AKMISLT44544000	44/54
AKMISLT50645000	50/64
AKMISLT06307005	63/70



BRACKETS - UPRIGHT

- * STAINLESS STEEL STRAPS

MODEL CODE	SERIE
AKMISRC50645000	50/64
AKMISRC06307005	63/70



63/27 SERIE - UPRIGHT INSTALLATION

- * UPRIGHT BRACKET INCLUDED
- * LEVEL GAUGE INCLUDED
- * RETURN COVER FLANGE INCLUDED
- * USE WITH COMMON BAYONET FILLER-BREATHER

FOR MORE DETAILS

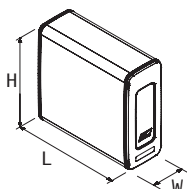

MODEL CODE	MATERIAL	CAPACITY GALLONS	DIMENSIONS (IN)			SUCCION CONNECTION	RETURN FILTER BOLT PATTERN
			L	H	W		
NSOF0200126US00	STEEL	53	49.7	25.1	10.7	2X 2" NPT	115 MM
NSOA0200126US00	ALUMINUM						175 MM
NSOA0250156US00	ALUMINUM	66	61.5				

64/50 SERIE - UPRIGHT INSTALLATION

- * MADE OF ALUMINUM
- * UPRIGHT BRACKET WITH SHOCK ABSORBER
- * LEVEL GAUGE INCLUDED
- * RETURN COVER FLANGE INCLUDED (2X)
- * USE WITH COMMON BAYONET FILLER-BREATHER

FOR MORE DETAILS

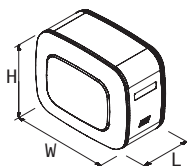

MODEL CODE	CAPACITY GALLONS	DIMENSIONS (IN)			SUCCION CONNECTION	RETURN FILTER BOLT PATTERN
		L	H	W		
NSOA0285100US00-K	75	39.4	25.1	21.0	3" NPT	115 MM
NSOA0375130US00-K	100	51.2			(2" NPT)*	2 RETURNS

* NPT ADAPTOR FROM 3" TO 2" NPT INCLUDED



DEVOTED TO
PROVIDING
GLOBAL
AUTOMATION
SOLUTIONS.

// Pneumatic Components & Systems



// Solenoid Valves



// Automation Solutions



OUR MISSION IS FOR YOU **TO ACHIEVE**
YOUR GOALS BY PROVIDING
INNOVATIVE & QUALITY PRODUCTS.



SLP SERIES

NORMAL OPEN



NORMAL CLOSE

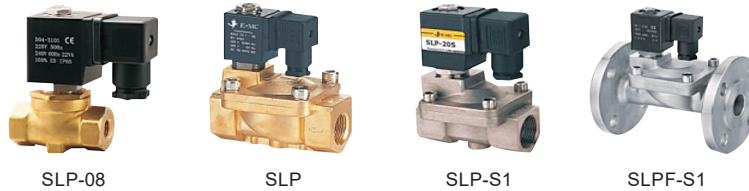

HOW TO ORDER

Series No.	Port Size	Original Status	Orifice	ID Code	Voltage	Valve Body Material	Seal Material	Thread Type
SLP: Thread connection SLPF: Flange connection		Blank: NC H: NO		Blank: Standard type N: Low power type		Blank: Brass S1: SS316	Blank: NBR E: EPDM V: VITON	Blank: G P: PT T: NPT
	06: 1/8 " 25: 1 "		010: 1mm	250: 25mm	E1: AC110V	E6: AC36V		
	08: 1/4 " 32: 1-1/4 "		015: 1.5mm	320: 32mm	E2: AC220V	E7: AC24V		
	10: 3/8 " 40: 1-1/2 "		025: 2.5mm	400: 40mm	E3: AC380V	E8: DC110V		
	15: 1/2 " 50: 2 "		030: 3mm	500: 50mm	E4: DC24V	E9: DC48V		
	20: 3/4 "		040: 4mm	650: 65mm	E5: DC12V	E10: DC36V		
			105: 10.5mm	800: 80mm				
			130: 13mm	1000: 100mm				
			200: 20mm					

ORDER EXAMPLE:

SLP SERIES SOLENOID VALVE, 1/2 PORT SIZE, NC, 13MM ORIFICE, STANDARD TYPE, AC110V, BRASS VALVE BODY, NBR SEAL, G THREAD, ERP CODE IS: SLP15-130E1

EMCJ SERIES

HOW TO ORDER

Series No.	Port Size	Actuator Size	Acting Type	Valve Body Material	Thread Type
EMCJ: Stainless Steel Series Angle Valve	10: 3/8 " 15: 1/2 " 20: 3/4 " 25: 1 " 32: 1-1/4 " 40: 1-1/2 " 50: 2 "	40: Ø40mm 50: Ø50mm 63: Ø63mm 80: Ø80mm 100: Ø100mm	Blank: NC Single Acting H: NO Single Acting D: Double acting	S1: SS316 S2: SS304	Blank: G P: PT T: NPT



EMCJ SERIES FULL STAINLESS STEEL SERIES ANGLE VALVE

ORDER EXAMPLE:

EMCJ SERIES FULL STAINLESS STEEL ANGLE SEAT VALVE, 3/8 PORT SIZE, 40MM ACTUATOR SIZE, NC SINGLE ACTING, SS316 VALVE BODY, G THREAD, ERP CODE IS: EMCJ-10-40S1

EMCP SERIES

HOW TO ORDER

Series No.	Port Size	Actuator Size	Acting Type	Valve Body Material	Thread Type
EMCP : Polymer Actuator Angle Valve	15 : 1/2 " 20 : 3/4 " 25 : 1 " 32 : 1-1/4 " 40 : 1-1/2 " 50 : 2 "	50 : Ø 50mm 63 : Ø 63mm 80 : Ø 80mm 100 : Ø 100mm	Blank : NC Single Acting H: NO Single Acting D: Double acting	S1 : SS316 S2 : SS304	Blank : G P : PT T : NPT



EMCP POLYMER ACTUATOR SERIES ANGLE VALVE

ORDER EXAMPLE:

EMCP, 3/4 PORT SIZE, 63 ACTUATOR SIZE, H NO SINGLE ACTING, S2 BODY MATERIAL, T NPT THREAD TYPE

THP SERIES 2/2 SOLENOID VALVE (STEAM VALVES)



THP-15TE2



THP-15TE2S2

HOW TO ORDER

Series No.	Port Size	Original Status	Orifice	ID Code	Voltage	Valve Body Material	Connection Mode	Seal Material	Thread Type	
THP Series	06: 1/8" 08: 1/4" 10: 3/8" 15: 1/2" 20: 3/4" 25: 1"	35: 1-1/4" 40: 1-1/2" 50: 2" 25F: 1" Flange 35F: 1-1/4" Flange 40F: 1-1/2" Flange 50F: 2" Flange	Blank: NC H: NO	2.5L: 2.5mm 4.5L: 4.5mm 15L: 15mm 35L: 35mm 45L: 45mm 20L: 20mm 25L: 25mm 35L: 35mm	Blank: Standard type	E1: AC110V E2: AC220V E3: AC380V E4: DC24V E5: DC12V E6: AC36V E7: AC24V E8: DC110V E9: DC48V E10: DC36V	Blank: Brass S1: SS316 S2: SS304	Blank: DIN Connector F: Flying leads	Blank: NBR T: Teflon V: VITON E: EPDM	Blank: G P: PT T: NPT

Note: Cancel if with same port size

ORDER EXAMPLE:

THP SERIES, 2 POSITION, 2 PORT, AC 110V, 1/8"PORT SIZE, ORIFICE: 2.5MM, BRASS, NORMAL CLOSE, NBR SEAL, DIN COIL, ERP CODE IS: THP06E1-2.5L

ESV SERIES 3/2 WAY DIRECT ACTING SOLENOID VALVE (NORMALLY CLOSE)



HOW TO ORDER

Series No.	Control Style	Port Size	Orifice	ID Code	Voltage	Valve Body Material	Coil Type	Seal Material	Thread Type
ESV Series ESV-N Series energy-saving solenoid valve (Voltage: 8-30VDC, Power: 2-6W)	1: Normal Close 2: Normal Open 3: Universal Type	06: 1/8 " 08: 1/4 "	1.5L: 1.5mm 2L: 2mm 2.5L: 2.5mm 3L: 3mm 4L: 4mm 5L: 5mm	Blank: Standard type N: Energy saving type	E1: AC110V E2: AC220V E4: DC24V E5: DC12V E7: AC24V	Blank: Brass S2: SUS304	Blank: DIN Type F: Flying Leads	Blank: NBR E: EPDM V: VITON	Blank: G P: PT T: NPT

ORDER EXAMPLE:

ESV SERIES, 2 POSITION, 3 PORT, NORMAL CLOSE, AC110V,1/8" PORT SIZE, ORIFICE:1.5MM, BRASS VALVE BODY, NBR SEAL, THE ERP CODE IS: ESV1-06-1.5LE1

NBC SERIES NFPA INTERCHANGEABLE

- MAX WORKING PRESSURE: 145 PSI
- NFPA INTERCHANGEABLE WITH MAJOR BRANDS
- INTEGRATED AIR CUSHIONS
- INTEGRATED MAGNET ON PISTON



NBC40x0200-S

HOW TO ORDER

Series No. Cushion Type Type No. Bore X Stroke Magnet No. Seal Material Mounting Type

C: Air cushion
NB: Profile barrel (North American Standard)
Blank: Basic type
D: Double shaft type
J: Double shaft and adjustable type

*Stroke length must be indicated as 4 digits.
First and second digit: Stroke/Inch
Third and fourth digit: Stroke/Hundredth of an inch
Example) 0525=5.25(5-1/4) inch stroke
Details in stroke chart

Blank: No magnet
S: With magnet

Blank: Standard material (NBR seal)
V: VITON seal

Blank: No
LB
CA
CB
FA
FB
YJ

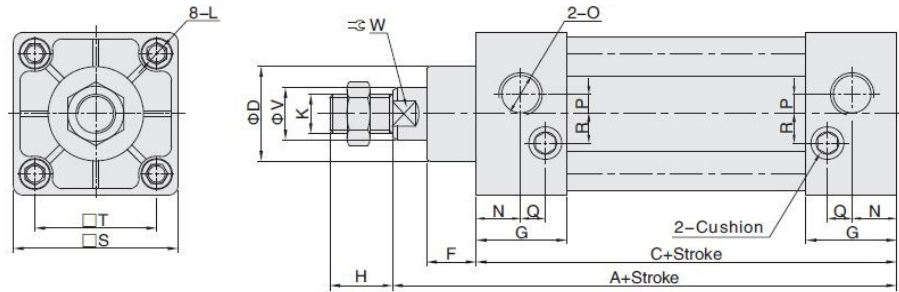

Bore	A	C	D	F	G	H	K	L	N	O	P	Q	R	S	T	V	W
40(1-1/2")	4.625	3.625	1.26	0.59	1.08	0.75	UNF 7/16-20-2A	M6	0.53	NPT1/4	0.197	0.216	0.35	1.97	1.457	0.63	0.50
50(2")	4.625	3.625	1.496	0.59	1.08	0.75	UNF 7/16-20-2A	M6	0.57	NPT1/4	0.335	0.118	0.433	2.44	1.85	0.787	0.50
63(2-1/2")	4.75	3.75	1.496	0.59	1.08	0.75	UNF 7/16-20-2A	M8	0.59	NPT3/8	0.28	0.197	0.374	2.95	2.205	0.787	0.50
80(3-1/4")	5.625	4.25	1.811	0.827	1.30	1.125	UNF 3/4-16-2A	M10	0.65	NPT3/8	0.28	0.31	0.39	3.70	2.756	0.984	0.87
100(4")	5.625	4.25	1.811	0.827	1.30	1.125	UNF 3/4-16-2A	M10	0.65	NPT1/2	0.30	0.31	0.51	4.41	3.307	0.984	0.87

NBC MOUNTING ACCESSORIES

NBC□-MSI

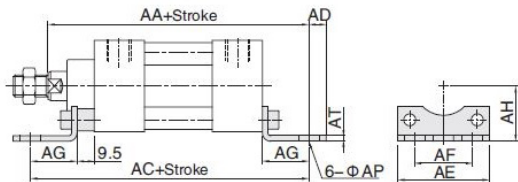

Bore	AA	AC	AD	AE	AF	AG	AH	AP	AT
40(1-1/2")	5.625	6.00	0.38	1.97	1.25	1.00	1.188	0.44	0.12
50(2")	5.625	6.00	0.38	2.44	1.75	1.00	1.438	0.44	0.12
63(2-1/2")	5.75	6.125	0.38	2.95	2.25	1.00	1.625	0.44	0.12
80(3-1/4")	6.875	7.375	0.50	3.74	2.75	1.25	1.938	0.56	0.16
100(4")	6.875	7.375	0.50	4.41	3.50	1.25	2.25	0.56	0.16

NBC□-MF1

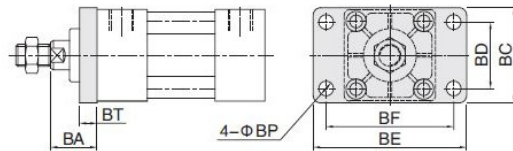

NBC□-MF2

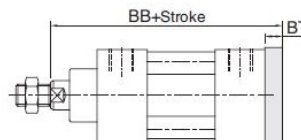

Bore	BA	BB	BC	BD	BE	BF	BP	BT
40(1-1/2")	1.00	5.00	2.05	1.43	3.31	2.75	0.315	0.375
50(2")	1.00	5.00	2.56	1.84	4.13	3.375	0.375	0.375
63(2-1/2")	1.00	5.125	2.87	2.19	4.57	3.875	0.375	0.375
80(3-1/4")	1.375	6.25	3.62	2.76	5.63	4.685	0.435	0.63
100(4")	1.375	6.25	4.50	3.31	6.34	5.435	0.435	0.63

NBC□-MP2

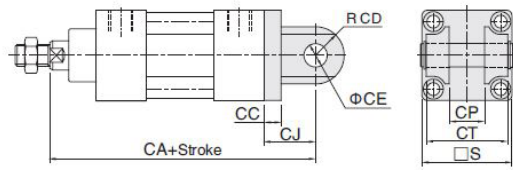

NBC□-YJ

PART NO: NBC40-YJ (40, 50, 63 BORE SIZES)
NBC80-YJ (80,100 BORE SIZES)

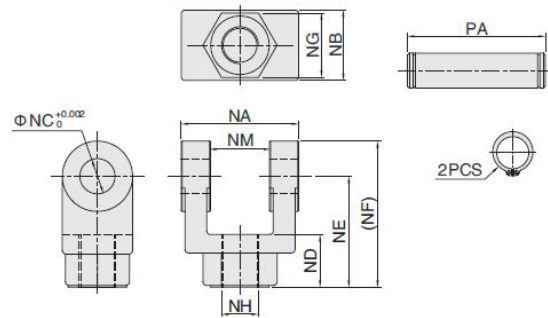

NBC□-MP4

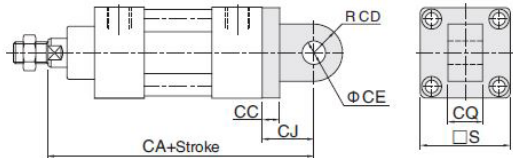

Bore	CA	CC	CD	CE	CJ	CP	CQ	CT	S
40(1-1/2")	5.75	0.38	0.62	0.50	1.125	0.765	0.75	1.765	1.95
50(2")	5.75	0.38	0.62	0.50	1.125	0.765	0.75	1.765	2.42
63(2-1/2")	5.875	0.38	0.62	0.50	1.125	0.765	0.75	1.765	2.93
80(3-1/4")	7.50	0.63	0.87	0.75	1.875	1.265	1.25	2.515	3.66
100(4")	7.50	0.63	0.87	0.75	1.875	1.265	1.25	2.515	4.37

Bore	NA	NB	NC	ND	NE	NF	NG	NH	NM	PA
40(1-1/2")	1.764	1.00	0.504	0.75	1.5	2.0	1.0	UNF-7/16-20-2A	0.764	2.17
50(2")	1.764	1.00	0.504	0.75	1.5	2.0	1.0	UNF-7/16-20-2A	0.764	2.17
63(2-1/2")	1.764	1.00	0.504	0.75	1.5	2.0	1.0	UNF-7/16-20-2A	0.764	2.17
80(3-1/4")	2.516	1.50	0.752	1.13	2.37	3.13	1.37	UNF 3/4-16-2A	1.264	2.95
100(4")	2.516	1.50	0.752	1.13	2.37	3.13	1.37	UNF 3/4-16-2A	1.264	2.95

FVBC SERIES ISO6431 / ISO15552

- * MAX WORKING PRESSURE: 145 PSI
- * ISO INTERCHANGEABLE WITH MAJOR BRANDS
- * INTEGRATED AIR CUSHIONS
- * INTEGRATED MAGNET ON PISTON



FVBC32X50-S

HOW TO ORDER

Series No.	Cushion Type	Type No.	Bore	X	Stroke	Adjustable Stroke	Magnet No.	Seal Material	Mounting Type	Thread Type
	C: Air cushion		32	25	10	Blank: No magnet		Blank: TPU seal	Blank: No	Blank: G
FVB: Square barrel			40	50	20	S: With magnet			CA	P: PT
FXB: Profile barrel			50	75	30				CB	T: NPT
			63	...	40				CR	
			80		50				LB	YJ
		Blank: Basic type	100		75				FA	BJ
		D: Double shaft type			100				FB	FD
		J: Double shaft and adjustable stroke type								

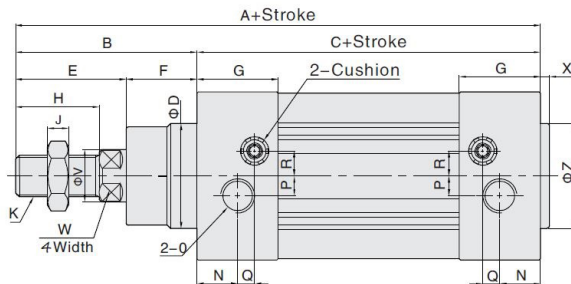
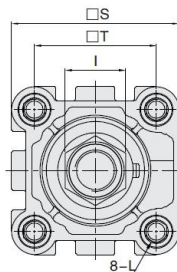

Bore/Sign	A	B	C	D	E	F	G	H	I	J	K	L	N	O	P	Q	R	S	T	V	W	X	Z
32	142	48	94	30	29	19	27.5	22	17	6	M10x1.25	M6	13	1/8"	5.5	6	6	46.5	32.5	12	10	3	30
40	159	54	105	35	33	21	32	24	17	7	M12x1.25	M6	17	1/4"	6	7.5	8.5	54	38	16	13	3.5	35
50	175	69	106	40	42	27	31	32	23	8	M16x1.5	M8	15.5	1/4"	7.5	6.5	9.5	64	46.5	20	17	3.5	40
63	190	69	121	45	42	27	33	32	23	8	M16x1.5	M8	16.5	3/8"	7.5	7.5	11.5	75	56.5	20	17	4	45
80	214	86	128	45	53	33	33	40	26	10	M20x1.5	M10	16.5	3/8"	8	8.5	12.5	93	72	25	22	4	45
100	229	91	138	55	55	36	37	40	26	10	M20x1.5	M10	19.5	1/2"	10	7	12	110	89	25	22	4	55

MOUNTING ACCESSORIES

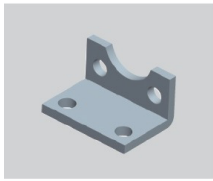

Model\Sign	AA	AC	AD	AE	AF	AG	AH	AP	AT
FJ-VBC32LB	158	142	8	47	32	24	32	7	4
FJ-VBC40LB	179	161	9	53	36	28	36	9	4
FJ-VBC50LB	190	170	10	65	45	32	45	9	5
FJ-VBC63LB	209	185	12	75	50	32	50	9	5
FJ-VBC80LB	248	210	19	95	63	41	63	12.5	6
FJ-VBC100LB	258	220	19	115	75	41	71	14.5	6

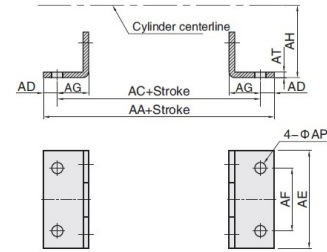

Model\Sign	AJ	AK	BA	BB	BC	BD	BE	BF	BH	BP	T
FJ-VBC32FA	11	7	30.5	10	47	32	80	64	4.5	7	32.5
FJ-VBC40FA	11	7	35.5	10	53	36	90	72	4.5	9	38
FJ-VBC50FA	14	9	40.5	12	65	45	110	90	5.5	9	46.5
FJ-VBC63FA	14	9	45.5	12	75	50	125	100	5.5	9	56.5
FJ-VBC80FA	17	11	45.5	16	95	63	154	126	7	12.5	72
FJ-VBC100FA	17	11	55.5	16	115	75	186	150	7	14.5	89

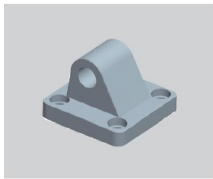
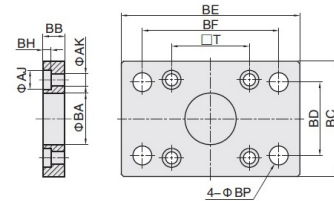

Model\Sign	S	T	DC	DD	DE	DJ	DQ
FJ-VBC32CA	47	32.5	22	9	10	13	25.8
FJ-VBC40CA	53	38	25	12	12	16	27.8
FJ-VBC50CA	65	46.5	27	12	12	17	31.8
FJ-VBC63CA	75	56.5	32	15	16	22	39.7
FJ-VBC80CA	95	72	36	15	16	22	49.7
FJ-VBC100CA	115	89	41	20	20	27	59.7

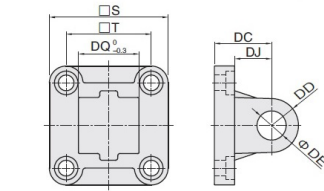

Model\Sign	CC	CD	CE	CJ	CP	CT	S	T
FJ-VBC32CB	22	9	10	13	26	45	47	32.5
FJ-VBC40CB	25	12	12	16	28	52	53	38
FJ-VBC50CB	27	12	12	17	32	60	65	46.5
FJ-VBC63CB	32	15	16	22	40	70	75	56.5
FJ-VBC80CB	36	15	16	22	50	90	95	72
FJ-VBC100CB	41	20	20	27	60	110	115	89

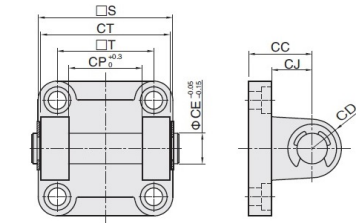

Model\Sign	S	T	DC	DD	DE	DF	DJ	DQ	DM	DN
FJ-VBC32CR	51	38	32	10	10	21	8	25.8	31	18
FJ-VBC40CR	54	41	36	11	12	24	10	27.8	35	22
FJ-VBC50CR	65	50	45	13	12	33	12	31.8	45	30
FJ-VBC63CR	67	52	50	15	16	37	12	39.7	50	35
FJ-VBC80CR	86	66	63	15	16	47	14	49.7	60	40
FJ-VBC100CR	96	76	71	19	20	55	15	59.7	70	50

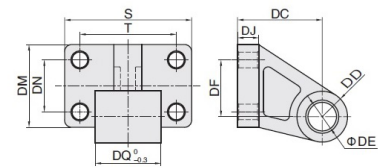

Model\Sign	NA	NB	NC	ND	NH	NM	NP	NQ
FJ-M10X1.25YJ	18	20	10	40	M10X1.25	10	20	52
FJ-M12X1.25YJ	20	24	12	48	M12X1.25	12	24	62
FJ-M16X1.5YJ	26	32	16	64	M16X1.5	16	32	83
FJ-M20X1.5YJ	34	40	20	80	M20X1.5	20	40	105

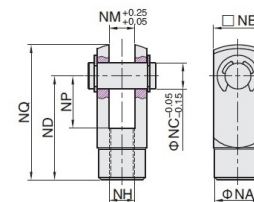

Model\Sign	NA	NC	ND	NE	NF	NG	NH	NM
FJ-M10X1.25 IJ	20	10	40	52	15	20	M10X1.25	10
FJ-M12X1.25 IJ	24	12	48	67	24	20	M12X1.25	12
FJ-M16X1.5 IJ	32	16	64	89	32	23	M16X1.5	16
FJ-M20X1.5 IJ	40	20	80	112	40	30	M20X1.5	20

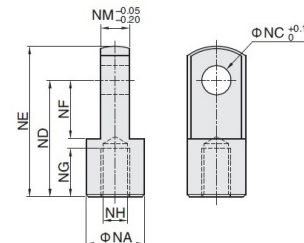



Model/Sign	ND	MB	MC	MD	ME	MF	MG	MH	MI
FJ-M10X1.25FD	58	22	6	28	8	12	M10X1.25	10	M10X1.25
FJ-M12X1.25FD	58	22	7	29	7	12	M12X1.25	12	M12X1.25
FJ-M16X1.5FD	90	27	8	51	12	14	M16X1.5	15	M16X1.5
FJ-M20X1.5FD	102	29	10	59	14	18	M20X1.5	22	M20X1.5

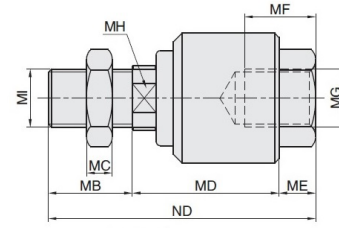

Model/Sign	A	B	C	D	E	G	H	I	J	K	M
FJ-M10X1.25BJ	57.5	44	15.5	28	10	8	M10X1.25	19	25	17	10.5
FJ-M12X1.25BJ	66.5	51.5	17	32	12	9.5	M12X1.25	22	25	19	12
FJ-M16X1.5BJ	85	65	25	40	16	11	M16X1.5	27	35	24	15
FJ-M20X1.5BJ	102	77	30	50	20	12.5	M20X1.5	34	40	30	18

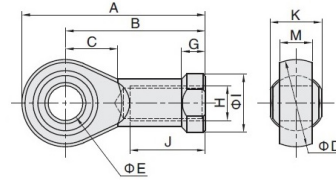

NCM STAINLESS STEEL MINI CYLINDERS

- * MAX WORKING PRESSURE: 145 PSI
- * INTERCHANGEABLE WITH MAJOR BRANDS
- * INTEGRATED RUBBER CUSHIONS
- * INTEGRATED MAGNET ON PISTON



NCM25X0500-S

HOW TO ORDER

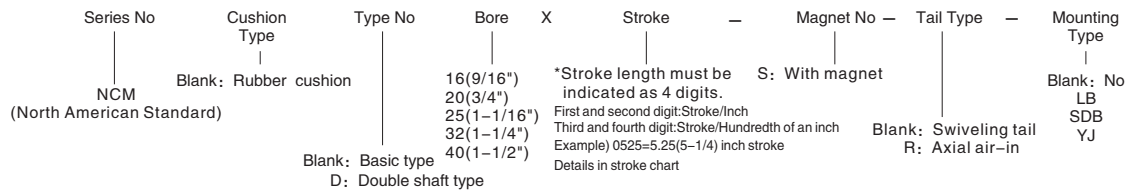

NCM Φ16

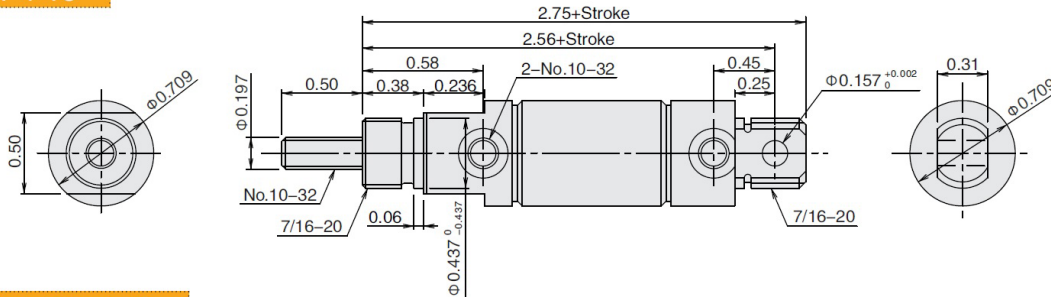

NCM Φ20-Φ40

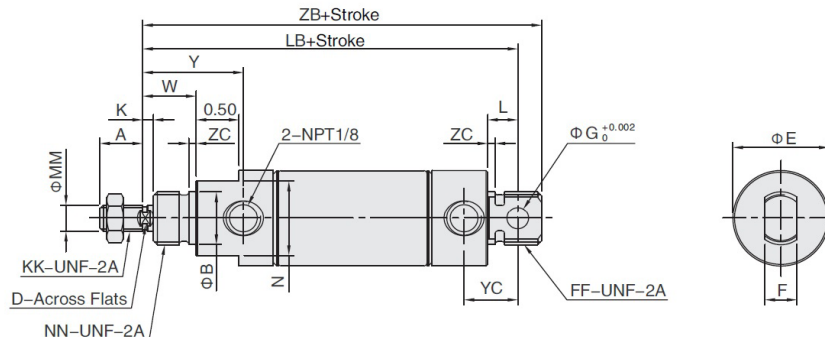

(inch)

Bore	MM	KK	A	B	D	E	F	FF	ΦG	K	L	N	NN	W	Y	YC	LB	ZB	ZC
20(3/4")	0.250	1/4-28	0.50	0.622 ⁰ _{-0.003}	-	0.87	0.38	5/8-18	0.252	-	0.34	0.75	5/8-18	0.50	0.815	0.654	3.75	4.03	0.08
25(1-1/16")	0.312	5/16-24	0.50	0.622 ⁰ _{-0.003}	0.25	1.12	0.38	5/8-18	0.252	0.12	0.34	0.88	5/8-18	0.62	0.933	0.654	3.84	4.12	0.08
32(1-1/4")	0.472	7/16-20	0.75	0.748 ⁰ _{-0.003}	0.38	1.38	0.50	3/4-16	0.252	0.25	0.41	1.06	3/4-16	0.88	1.283	0.811	4.47	4.87	0.08
40(1-1/2")	0.472	7/16-20	0.75	0.748 ⁰ _{-0.003}	0.38	1.65	0.62	3/4-16	0.378	0.25	0.50	1.25	3/4-16	0.88	1.268	0.886	4.38	4.75	0.08

NCM MOUNTING ACCESSORIES

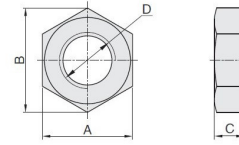
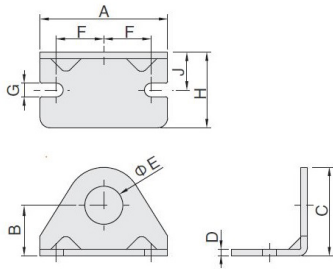

MODEL CODE	BORE	DIMENSIONS (IN)								
		A	B	C	D	E	F	G	H	J
NCM16-LB	16	1.38	0.56	0.83	0.09	0.44	0.50	0.19	0.69	0.38
NCM2025-LB	20 & 25	1.89	0.81	1.36	0.12	0.63	0.75	0.27	0.98	0.56
NCM3240-LB	32 & 40	2.52	1.00	1.75	0.12	0.75	0.94	0.27	1.50	0.75

MODEL CODE	THREAD	DIMENSIONS (IN)		
		A	B	C
JM-02	No10-32 UNF	0.31	0.35	0.16
JM-025	1/4-28 UNF	0.39	0.44	0.16
JM-03	5/16-24 UNF	0.51	0.58	0.20
JM-045	7/16-20 UNF	0.67	0.78	0.24
JM-08	5/8-18 UNF	0.95	1.07	0.31
JM-10	3/4-16 UNF	1.06	1.21	0.39

REED SWITCHES



- * 2 WIRE TYPE, 1 METER LENGHT
- * OPERATING VOLTAGE: 5-240V DC/AC
- * NORMALLY OPEN SIGNAL
- * RED LED INDICATOR

MODEL CODE	FIT MODELS	BRACKET
HX-21R	NBC	PL
HX-31R	FVBC	IH
HX-03R	NCM	BK-81

REED SWITCH BRACKETS

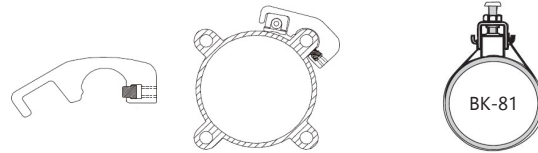

MODEL CODE	FIT MODELS
PL-1	NBC40
PL-2	NBC50
	NBC63
PL-3	NBC80
PL-4	NBC100

MODEL CODE	FIT MODELS
IH-32	FVBC32
IH-40	FVBC40
IH-50	FVBC50
IH-63	FVBC63
IH-80	FVBC80
IH-100	FVBC100

ALSO AVAILABLE



COMPACT CYLINDERS
SQ SERIES



METRIC MINI STAINLESS
STEEL CYLINDERS
IAC SERIES



REPAIRABLE CYLINDER
EG SERIES



GUIDED CYLINDER
SG SERIES



ROTARY CYLINDER
EMQ SERIES



AIR GRIPPER
SHZ SERIES

LEVER VALVES

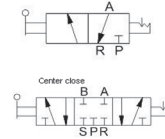

MODEL CODE	DESCRIPTION	PORT SIZE	MODEL CODE	DESCRIPTION	PORT SIZE
H322-08-T	3/2 DETENT	1/4 NPT	H532C-08-T	5/3 DETENT, CLOSED CENTER	1/4 NPT
H323-10-T		3/8 NPT	H532C-08S-T		
H522-08-T	5/2 DETENT	1/4 NPT	H532E-08-T	5/3 DETENT, EXHAUST CENTER	1/4 NPT
H522-08S-T			5/2 SPRING RETURN		
H523-10-T	5/2 DETENT	3/8 NPT	H533C-10-T	5/3 DETENT, CLOSE CENTER	3/8 NPT
H524-15T		1/2 NPT	H533C-10S-T		

BUTTON VALVES

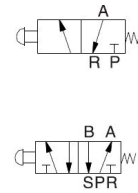

M32-06S1B-T

MV32-06S2-T

MV32-06S3R-T

MJ32-06S5R-T

MJ32-06S4G-T

M52-08S6R-T

MODEL CODE	DESCRIPTION	PORT SIZE	MODEL CODE	DESCRIPTION	PORT SIZE
M32-06S1B-T	3/2 , TWIST SELECTOR, BLACK	1/8 NPT	MV32-06S4G-T	3/2, SPRING RETURN, PUSH BUTTON, GREEN	1/8 NPT
M52-08S1B-T	5/2 , TWIST SELECTOR, BLACK	1/4 NPT	MJ32-08S4G-T		1/4 NPT
MV32-06S2-T	3/2, SPRING RETURN, ROLLER TYPE	1/8 NPT	M32-08S4G-T		1/4 NPT
MJ32-08S2-T		1/4 NPT	MV32-06S5R-T	3/2, SPRING RETURN PUSH BUTTON, FLUSH, RED	1/8 NPT
M52-08S2-T	5/2, SPRING RETURN, ROLLER TYPE	1/4 NPT	MJ32-08S5R-T	3/2, SPRING RETURN PUSH BUTTON, FLUSH, RED	1/4 NPT
MV32-06S3R-T	3/2, PUSH BUTTON, RED, EMERGENCY STOP, RESET	1/8 NPT	MV32-06S6R-T	3/2 SPRING RETURN, PUSH BUTTON, RED MUSHROOM	1/8 NPT
MJ32-08S3R-T		1/4 NPT	MJ32-08S6R-T	3/2 SPRING RETURN, PUSH BUTTON, RED MUSHROOM	1/4 NPT
M32-06S3R-T		1/8 NPT	M52-08S6R-T	5/2 SPRING RETURN, PUSH BUTTON, RED MUSHROOM	1/4 NPT
M32-08S3R-T		1/4 NPT			

FOOT PEDALS

MODEL CODE	DESCRIPTION	PORT SIZE
F322-08-T	3/2, SPRING RETURN	1/4 NPT
F422-08-T	4/2, SPRING RETURN	
F522-08-T	5/2, SPRING RETURN	
F522-08L-T	5/2, WITH LOCK 1/2	
F522C-08-T	5/2, WITH GUARD	

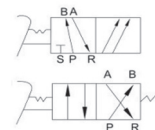

ROTARY VALVES

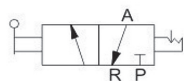

MODEL CODE	DESCRIPTION	PORT SIZE
R432-08-T	4/3 DETENT	1/4 NPT
R432-10-T		3/8 NPT

HAND PULL VALVES



MODEL CODE	DESCRIPTION	PORT SIZE
L523-10-T	5/2, DETENT	3/8 NPT
L524-15-T		1/2 NPT

FLOW CONTROL VALVES



MODEL CODE	PORT SIZE
RE-06-T	1/8 NPT
RE-08-T	1/4 NPT
RE-10-T	3/8 NPT
RE-15-T	1/2 NPT

SLIDE VALVES

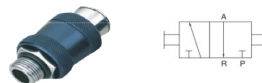

MODEL CODE	PORT SIZE
YHS-08FF-T	1/4 NPT
YHS-10FF-T	3/8 NPT
YHS-15FF-T	1/2 NPT
YHS-20FF-T	3/4 NPT
YHS-25FF-T	1" NPT

QUICK EXHAUST VALVES



MODEL CODE	PORT SIZE
KKP-06-T	1/8 NPT
KKP-08-T	1/4 NPT
KKP-10-T	3/8 NPT
KKP-15-T	1/2 NPT

3 WAY SOLENOID VALVES

HOW TO ORDER



Standard Solenoid Valve

Series No.	Ports	Positions	Valve Body ID Code	Controls	Original Status	Port Size	Reset Typt	ID Code	Voltage	Connection Mode	Cover Color	Valve Color	Thread Type
RV	3: 3 ports	2: 2 positions	1: 1Series 2: 2Series 3: 3Series 4: 4Series	1: Single control 2: Double control	Blank: Normal close H: Normal open	M5: M5 06: 1/8" 08: 1/4" 10: 3/8" 15: 1/2"	Blank: Spring (Only 4 series single control) Q: Air (1,2,3 series single control)	Blank: Standard type A: Amisco coil	E1: AC110V E2: AC220V E3: AC380V E4: DC24V E5: DC12V	Blank: DIN connector F: Flying leads K: Waterproof DIN connector (Only for 2,3,4 series)	E6: AC36V E7: AC24V E8: DC110V E9: DC48V E10: DC36V	Blank: Brown translucent J: Colorless and translucent B: Black (Only Waterproof DIN connector)	Blank: Internal pilot WB: External pilot Blank: G P: PT T: NPT

5 WAY SOLENOID VALVES

HOW TO ORDER



Standard Solenoid Valve

Series No.	Ports	Positions	Valve Body Size	Controls	Original Status	Port Size	Reset Form	ID Code	Voltage	Connection Mode	Cover Color	Acting Type	Thread Type
RV	5:5 ports	2: 2 positions 3: 3 positions	1: 1Series 2: 2Series 3: 3Series 4: 4Series	1: Single control 2: Double control	C: Center close P: Center pressure E: Center exhaust (Only for 5/3 way)	M5: M5 06: 1/8" 08: 1/4" 10: 3/8" 15: 1/2"	Blank: Spring Q: Air (Only single control)	Blank: Standard type A: Amisco coil	E1: AC110V E2: AC220V E3: AC380V E4: DC24V E5: DC12V	Blank: DIN connector F: Flying leads K: Waterproof DIN connector (Only 2, 3, 4 series is optional)	E6: AC36V E7: AC24V E8: DC110V E9: DC48V E10: DC36V	Blank: Brown translucent J: Colorless and translucent	Blank: Internal pilot WB: External pilot Blank: G P: PT T: NPT

MANIFOLD MOUNT SOLENOID VALVES

HOW TO ORDER



SR Valve Group:

Series No.	Valve Body Size	ID code	Valve Numbers	Controls	Port Size	Voltage	Coil Type	Thread Type	Mounting Type
S: Common type SN: Low power type	R: RV series valve		3:3valves 4:4valves 5:5valves 6:6valves 7:7valves 8:8valves	S: Single coil	M5: M5 06: 1/8" 08: 1/4"	E4:DC24V E5:DC12V (Only DC24V for low power type)	Blank: Plug-in type	Blank: G P: PT T: NPT	Blank: No accessory D: Din guide rail clip with 1 meter din guide rail DO: Din guide rail clip without din guide rail (Din guide rail packed separatly)
1: 1 series 2: 2 series			9:9valves 10:10valves 11:11valves 12:12valves 13:13valves 14:14valves						

FILTERS

- * MAX WORKING PRESSURE: 145 PSI
- * FILTRATION: 5 MICRONS
- * MANUAL DRAIN (AUTO-DRAIN AVAILABLE)

MODEL CODE	PORT SIZE	MAX L/MIN
EIF2000-015M-T	1/8 NPT	1000
EIF2000-025M-T	1/4 NPT	1100
EIF3000-035M-T	3/8 NPT	2148
EIF4000-045M-T	1/2 NPT	5430
EIF5000-065M-T	3/4 NPT	8200
EIF5000-105M-T	1 NPT	8200



LUBRICATORS

- * MAX WORKING PRESSURE: 145 PSI
- * FILTRATION: 5 MICRONS

MODEL CODE	PORT SIZE	MAX L/MIN
EIL2000-01-T	1/8 NPT	1300
EIL2000-02-T	1/4 NPT	1345
EIL3000-03-T	3/8 NPT	2375
EIL4000-04-T	1/2 NPT	5532
EIL5000-06-T	3/4 NPT	7700
EIL5000-10-T	1 NPT	8000



REGULATORS

- * MAX WORKING PRESSURE: 145 PSI
- * ADJUSTMENT RANGE: 7-123 PSI
- * PRESSURE GAUGE INCLUDED

MODEL CODE	PORT SIZE	MAX L/MIN
EIR2000-013-T	1/8 NPT	1178
EIR2000-023-T	1/4 NPT	1200
EIR3000-033-T	3/8 NPT	2212
EIR4000-043-T	1/2 NPT	5312
EIR5000-063-T	3/4 NPT	6400
EIR5000-103-T	1 NPT	6600



FILTER + REGULATORS

- * MAX WORKING PRESSURE: 145 PSI
- * ADJUSTMENT RANGE: 7-123 PSI
- * PRESSURE GAUGE INCLUDED
- * FILTRATION: 5 MICRONS
- * MANUAL DRAIN (AUTO-DRAIN AVAILABLE)

MODEL CODE	PORT SIZE	MAX L/MIN
EIW2000-0135M-T	1/8 NPT	1078
EIW2000-0235M-T	1/4 NPT	1165
EIW3000-0335M-T	3/8 NPT	2177
EIW4000-0435M-T	1/2 NPT	5211
EIW5000-0635M-T	3/4 NPT	6200
EIW5000-1035M-T	1 NPT	6400



FRL'S

- * MAX WORKING PRESSURE: 145 PSI
- * ADJUSTMENT RANGE: 7-123 PSI
- * PRESSURE GAUGE INCLUDED
- * FILTRATION: 5 MICRONS
- * MANUAL DRAIN (AUTO-DRAIN AVAILABLE)

MODEL CODE	PORT SIZE	MAX L/MIN
EIC2000-0135M-T	1/8 NPT	1000
EIC2000-0235M-T	1/4 NPT	1100
EIC3000-0335M-T	3/8 NPT	2105
EIC4000-0435M-T	1/2 NPT	5200
EIC5000-0635M-T	3/4 NPT	6200
EIC5000-1035M-T	1 NPT	6500



L TYPE BRACKETS

MODEL CODE	MODELS
Y20L	2000
Y30L	3000
Y40L	4000
Y50L	5000



T TYPE BRACKETS

MODEL CODE	MODELS
Y20T	2000
Y30T	3000
Y40T	4000
Y50T	5000



ONE TOUCH FITTINGS

- * ONE TOUCH PUSH-TO-CONNECT CONFIGURATION ALLOWS AN INSTANT TUBING CONNECTION.
- * SMOOTH EDGE RELEASE SLEEVE DESIGN FACILITATES A QUICK TUBING DISCONNECTION.
- * PRE-APPLIED SEALANT ON ALL EXTERNAL THREADS.

HOW TO ORDER

Series No.	Tube outside diameter		Thread size	Thread type
ZPC	04: 4 mm	5/32: 5/32"	M5: M5	P: PT
ZPCF	06: 6 mm	3/16: 3/16"	M6: M6	G: G
ZPOC	08: 8 mm	1/4: 1/4"	01: 1/8"	T: NPT
...	10: 10 mm	5/16: 5/16"	02: 1/4"	
	12: 12 mm	3/8: 3/8"	03: 3/8"	
	16: 16 mm	1/2: 1/2"	04: 1/2"	



POLYURETHANE TUBING

* MAX WORKING PRESSURE: UP TO 145 PSI

HOW TO ORDER

Series No.	O.D.		X	I.D.	Length	Color code
PU: PU Tube	040: 4 mm	5/32	5/32"	025: 2.5 mm	20M: 20M/Roll	BU: Blue
	060: 6 mm	3/16	3/16"	040: 4 mm	30M: 30M/Roll	B: Black
	080: 8 mm	1/4	1/4"	050: 5 mm	100M: 100M/Roll	C: Transparent
	100: 10 mm	3/8	3/8"	060: 6 mm	200M: 200M/Roll	O: Orange
	120: 12 mm	1/2	1/2"	065: 6.5mm	(Only ø4x2.5 and ø6x4 are 200m/Roll)	R: Red
	160: 16 mm			080: 8 mm		W: White
			100: 10 mm		G: Green	
			120: 12 mm		Y: Yellow	



AVAILABLE COLORS

Metric	BU	B	Clear	O	R	W	G	Y
4mm	√	√	√	√	√	√	√	√
6mm	√	√						
8mm	√	√						
10mm	√	√						
12mm	√	√						
16mm	√	√						

Imp.	BU	B	Clear	O	R	W	G	Y
5/32"	√	√	√		√	√	√	√
3/16"	√	√						
1/4"	√	√	√	√	√	√	√	√
5/16"	√	√						
3/8"	√	√	√					
1/2"	√	√						

TUBE CUTTER

MODEL CODE: ECP-01



MUFFLERS



MODEL CODE	PORT SIZE
V-06T	1/8 NPT
V-08T	1/4 NPT
V-10T	3/8 NPT
V-15T	1/2 NPT
V-20T	3/4 NPT
V-SAE6	SAE-06
V-SAE8	SAE-08

MODEL CODE	PORT SIZE
A-06T	1/8 NPT
A-08T	1/4 NPT
A-10T	3/8 NPT
A-15T	1/2 NPT
A-20T	3/4 NPT
A-25T	1 NPT

MODEL CODE	PORT SIZE
SB-06T	1/8 NPT
SB-08T	1/4 NPT
SB-10T	3/8 NPT
SB-15T	1/2 NPT
SB-20T	3/4 NPT

Customized service for any project size

Hydrolico's sales team and outstanding customer service department work closely with technical support to help you select the best product solutions for your needs. Our reliable and durable components and systems will meet all your technical specifications, ensuring your complete satisfaction.

Your one-stop shop for hydraulics, pneumatics and automation.

- High-value fluid power systems
- High hand simulation tools
- Consultation services
- Support team : troubleshooting, field installation, startup, data logging
- Benchmarking
- Turnkey solutions
- Customized training

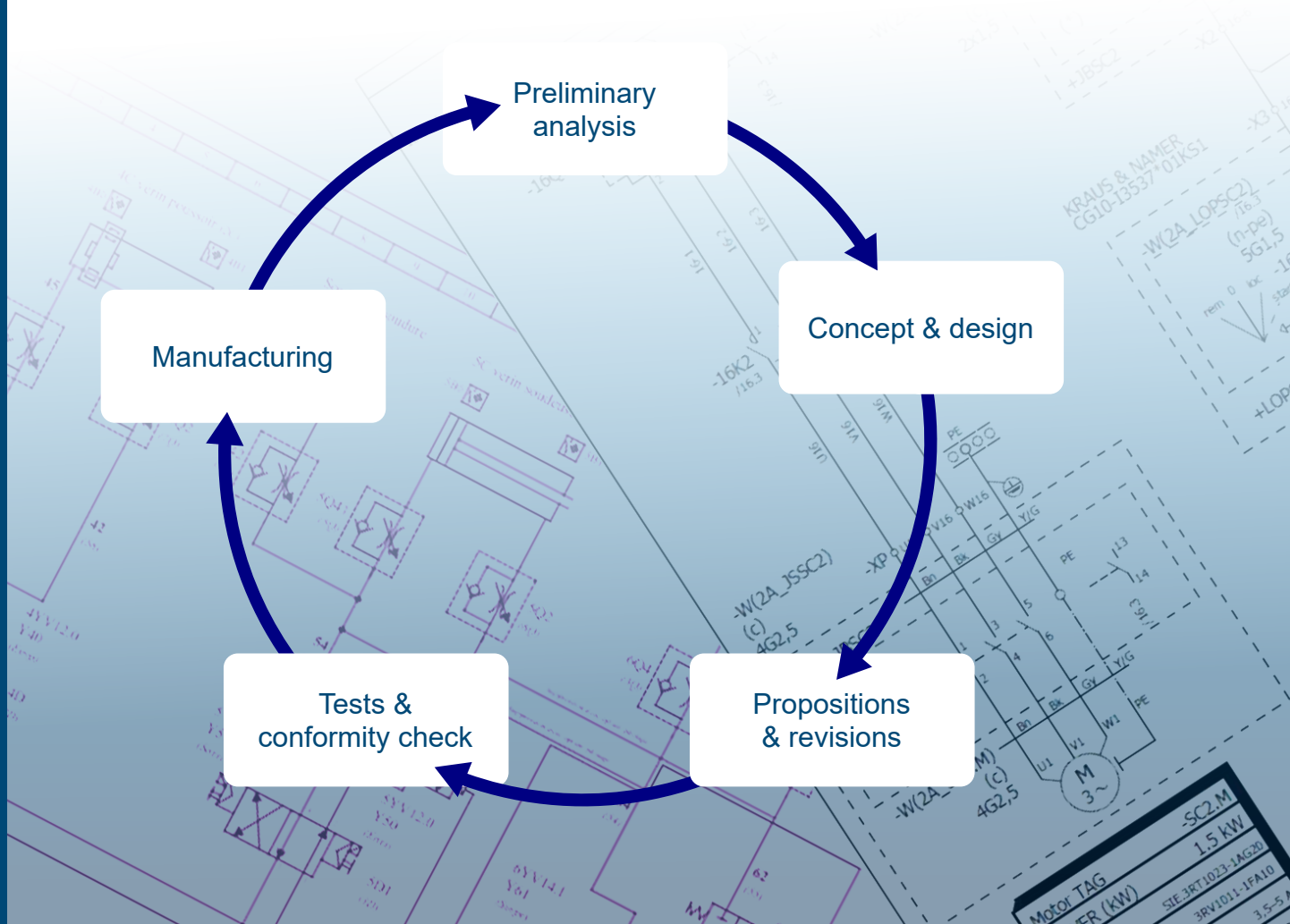

HYDRAULIC POWER UNITS (HPU)

- DESIGN AND MANUFACTURING BASED ON YOUR SPECS
- HYDRAULIC CABINETS
- ELECTRO-HYDRAULIC AND PROPORTIONAL SYSTEMS
- TURNKEY SYSTEMS
- MODIFICATION, REPAIR, RECONDITIONING, STARTER AND TROUBLESHOOTING SERVICES
- ANALYSIS AND SIMULATION WITH AUTOMATION STUDIO™ SOFTWARE



MANIFOLDS

- DESIGN AND MANUFACTURING IN ACCORDANCE WITH NFPA STANDARDS OR BASED ON YOUR SPECS
- ALUMINUM, STEEL AND STAINLESS STEEL
- SINGLE OR FOR HIGH-VOLUME PRODUCTION UNIT

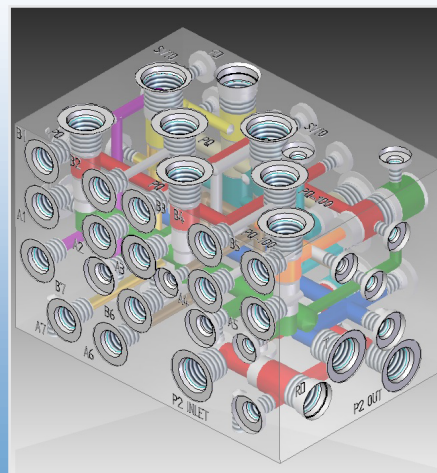
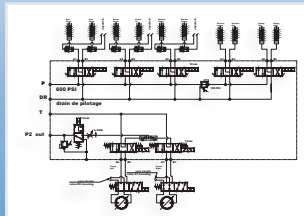

PNEUMATIC SYSTEMS

- DESIGN AND MANUFACTURING BASED ON YOUR SPECS
- ELECTRO-PNEUMATIC SYSTEMS
- INTEGRATED CABINETS
- PNEUMATIC AUTOMATION

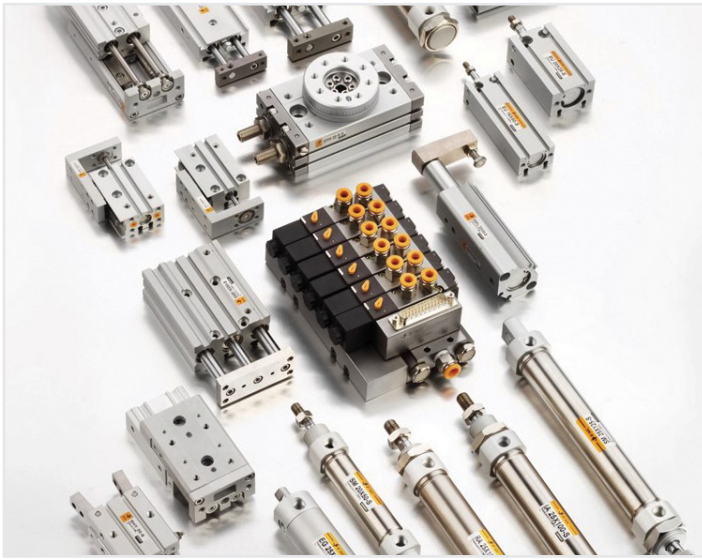

AUTOMATION

- INTEGRATION PARTNER - DRACON
- CUSTOM DESIGN AND MANUFACTURING OF POWER UNITS AND CONTROL PANELS
- AUTOMATION AND CONTROL REPLACEMENT PARTS
- INTEGRATION OF YOUR AUTOMATED SYSTEMS: PLC, HMI (HUMAN MACHINE INTERFACE), SCADA SOFTWARE, SERVOMOTORS, ROBOTS AND VISION SYSTEMS

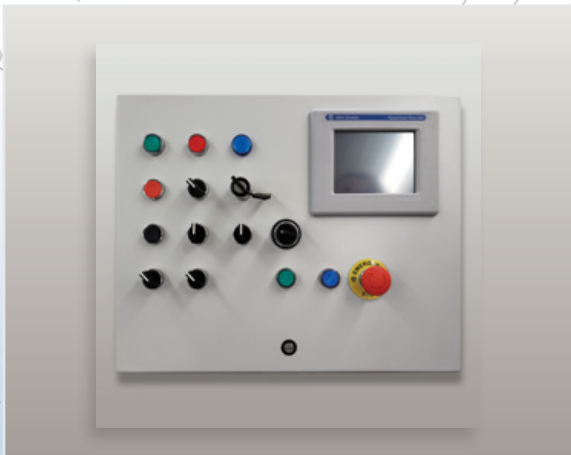

 HC Hydro Custom

Terms & Conditions

1 Presentation

Bailey International, LLC, Hydrolico International Inc, and their respective parent companies, subsidiaries, and affiliates (collectively, “Hydrolico,” “we,” or “our”) have created these Terms and Conditions (“Terms”) governing our provision of products and services. Our Privacy Policy and Online Services Terms of Use are available here and are incorporated into these Terms by reference, as if they were completely restated here.

BY ORDERING PRODUCTS (DEFINED BELOW) FROM HYDROLICO, THE CUSTOMER (DEFINED BELOW) AGREES TO THESE TERMS, WHICH, TOGETHER WITH ANY PURCHASE ORDER (DEFINED BELOW) AND ALL PRODUCT SPECIFICATIONS (DEFINED BELOW) PROVIDED OR SIGNED BY THE CUSTOMER AND ACCEPTED BY HYDROLICO, COLLECTIVELY FORM A BINDING AND ENFORCEABLE AGREEMENT BETWEEN HYDROLICO AND THE CUSTOMER.

These Terms modify and replace the existing Hydrolico Terms and Conditions. These Terms come into effect on May 1, 2023.

2 Definitions

Unless the context requires otherwise, the following words or phrases, when capitalized, have the meaning ascribed to them below.

2.1 Purchase Order

“Purchase Order” means all documents titled “Purchase Order” and any other order request confirmation, including signed drawings, online orders, fax orders, email orders, letters, and telephone confirmations.

2.2 Customer

“Customer” means the customer named on any purchase order or supply agreement for any product, and includes individuals, as well as any business or other person that the individual represents.

2.3 Products

“Products” or “Product” means all hydraulic components manufactured or distributed by Hydrolico and all other goods purchased by Bailey for resale, as well as all services provided by Hydrolico in connection with any Products.



2.4 Product Specifications

“Product Specifications” means all descriptions, documents, images, drawings, manuals, instructions, and warnings that in any way describe or specify the design, function, appearance, materials, use, operation, maintenance, disposal, disassembly, or demolition of any Product supplied by Bailey.

3 No Variation of the Terms

The Product supply arrangement between Hydrolico and the Customer is subject to and governed by these Terms. Any variation of these and any additional or different terms or conditions on any document submitted by the Customer are hereby expressly rejected. All orders are subject to acceptance by Hydrolico and all accepted orders are governed by these Terms. Any representation, current transaction, or promise or condition or commercial use not incorporated herein is not binding on Hydrolico. In the event of a conflict between the Terms and any Purchase Order, these Terms will prevail.

4 Ordering Procedures

The Customer places orders with Hydrolico using a Purchase Order. The Purchase Order must include the order number, the products to be supplied, the prices, the quantities, the required date, the place of delivery and the Customer's contact information.

By placing an order for Products with Hydrolico, the Customer states and warrants that he has the authority to enter into a legally binding agreement on behalf of any entity or other person that he represents.

Upon receipt of the Purchase Order, Hydrolico will confirm in writing its acceptance or refusal of the Purchase Order.

The Purchase Order will include the terms and conditions set out in these Terms without the need to expressly refer to them.

Within five (5) business days of its acceptance, Hydrolico may refuse a Purchase Order if additional information is required or if Hydrolico is unable to provide the products ordered within the timeframe set out in the Purchase Order. If applicable, Hydrolico will notify the Customer in writing of its refusal of the Purchase Order.

5 Product pricing

All Products will be invoiced in accordance with Hydrolico's price schedule in effect at the time of the order.

The prices indicated in the price schedule do not include taxes. All sales, use, excise, property, business and other applicable taxes are the responsibility of the Customer and payable by the Customer to Hydrolico. If the Customer requests an exemption from any taxes, the Customer must provide written proof of the exemption and indemnify and hold Hydrolico harmless with respect to such taxes, interest, and penalties. Products may also be subject to import taxes, customs duties, and/or fees imposed by government regulations. These costs are the responsibility of the Customer and will be additional costs unless otherwise specified.

All prices on orders that have not yet been processed and accepted are subject to change without notice. Hydrolico reserves the right to correct any printing errors on the website or catalogue. Mixing of Product quantities to obtain volume discounts is only allowed on certain Products and will be done so at Hydrolico's sole discretion.

Hydrolico reserves the right to charge a non-refundable deposit for custom-made Products and/or Products that are shipped quickly. These deposits must be paid before Hydrolico begins production. If the Customer attempts to cancel or terminate an order for a custom-made Product, Hydrolico will keep the deposit as damages and not as a penalty. Notwithstanding the above, the Customer may not cancel or terminate an order for a Custom Product if the production of the Product has begun.

6 Payments

Unless otherwise agreed in writing by Hydrolico at the time of order processing, payment for all Products must be made prior to shipment. Hydrolico offers certain credit facilities through its credit department, which are subject to acceptance by Hydrolico and the credit terms are at its sole discretion.

Hydrolico International Inc.
Accounts Receivable
55 rue Théodore-Viau, Terrebonne, QC J6Y 0J8, Canada.

Hydrolico may suspend or delay the manufacture and/or shipping of subsequent Products or cancel or terminate pending orders due to late payments by the Customer. The Customer will reimburse Hydrolico for all damages incurred by Hydrolico as a result of such delay, cancellation or termination. The balance of the unpaid bills will increase at an interest rate of one percent (1%) per month (12% per year).

7 Shipping

All products will be delivered FOB to the Hydrolico shipping point by Incoterm. Hydrolico will determine the shipping and delivery method unless a prior written agreement between Hydrolico and the Customer is in place. All shipping and delivery dates provided by Hydrolico are approximate. Hydrolico shall not be held liable for delays in the delivery of any product for any reason or for the costs associated with this. Hydrolico shall not be responsible for handling fees or other transportation costs or incidental expenses.

The Customer bears all the risks of loss of the Products, upon delivery by Hydrolico to the carrier or upon collection by the Customer at the Hydrolico warehouse. The Customer will be responsible for filing and pursuing claims with carriers for loss or damage to Products in transit. Hydrolico makes no representation with respect to the authorizations that may be required to ship Products and assumes no responsibility in this regard. The Customer undertakes to carry out the checks and to obtain all the authorizations that may be required for transport.

Hydrolico may deliver the Products in several batches and bill each batch separately. Any request by the Customer to cancel part of an order prior to delivery must be made in writing. The Customer will pay the full cost of completed custom orders and stored custom components. Items held at Hydrolico at the request of the Customer or as a result of a failure by the Customer will incur storage fees of five percent (5%) per month of the total amount of the Purchase Order. Any order shipped by Hydrolico and refused by the Customer will be treated as a Product return. Special orders and/or Custom Products, including but not limited to cut rods and tubes, cannot be cancelled. Hydrolico may, without prejudice to any other right or remedy, cancel any order from the Customer or postpone shipping in the following events: the Customer does not pay the amount due to Hydrolico by the due date;

- (i) the financial situation of the Customer is unsatisfactory to Hydrolico, at our sole discretion;
- (ii) the Customer does not comply with any applicable law, rule, or regulation; or
- (iii) the Customer does not comply with these Terms, the Privacy Policy, or any other agreement with Hydrolico.

8 Product Returns

Product returns are authorized at Hydrolico's sole discretion. The Customer must not return products without the prior written authorization of Hydrolico and without marking such return with a Hydrolico Return Merchandise Authorization ("RMA") number provided by Hydrolico for such return. RMAs can only be obtained from Hydrolico by calling (450-628-6644) or 877-628-6644, or by making a request via email to info@hydrolico.com. The Customer shall assume all risks associated with the return of any Product. Returned Products must be received by Hydrolico within forty-five (45) days of receipt of the Product by the Customer, at the location designated by Hydrolico. Returned Products must not have been used, and must be free from any damage, be safely packed and marked with the name of the Customer and the RMA issued by Hydrolico.



Credit for any returned Product, if such credit is due, will be issued based on the lesser of the original invoice price or the current selling price. The issuance of a credit is contingent upon Hydrolico's satisfaction upon receipt of the Product and compliance with the return procedures provided in the previous paragraph. Special orders and Custom Products, including but not limited to cut rods and tubes, cannot be returned. Hydrolico may charge the Customer a restocking fee, which shall not exceed twenty percent (20%) of the amount initially invoiced to the Customer for the returned Product, in addition to all shipping costs (including, for greater certainty but not limited to, any applicable taxes or customs duties). This invoice is due within fifteen (15) days of receipt. The payment terms of article 6 apply with the necessary adjustments.

9 Custom Products

Hydrolico may choose to prepare one (1) or more drawings for the design of Customized Products on behalf of the Customer based on the Customer's design and instructions. Hydrolico will provide a copy of these drawings to the Customer as a submission for the manufacturing of a Custom Product. To accept Hydrolico's submission, the Customer must sign and return the drawings to Hydrolico by email or by any other method acceptable to Hydrolico. The Customer's signature on these drawings will constitute a verification by the Customer that Hydrolico's design of the Custom Product meets the Customer's requirements. In the event that the Customer provides one (1) or more of its own drawings for Hydrolico to manufacture a Custom Product, Hydrolico may make necessary changes, consistent with Hydrolico's design and manufacturing capabilities, and subsequently provide the Customer with drawings approved by Hydrolico for Customer's acceptance and signature. Drawings signed by the Customer in accordance with the provisions of this section ("Signed Drawings") will form part of these Terms with respect to the applicable Products, regardless of the original supplier of these drawings or if changes are made to them by Hydrolico or the Customer.

Once Hydrolico receives the signed drawings, Hydrolico will not modify any Key Attributes (defined below) of a custom Product design without obtaining the Customer's consent. The Customer's signature on the updated drawing(s) shall constitute the Customer's consent to these modifications. Once Hydrolico receives the signed drawings, the Customer must request any changes to any Key Attributes in the Custom Product design, by providing Hydrolico, or by requesting Hydrolico to provide updated drawings that reflect these proposed or requested changes to the design for the Customer's signature. Hydrolico's acceptance of any updated design will be communicated to the Customer in writing. As used here, "Key Attribute" includes bore diameter, stroke, retracted length, and mounting type. Hydrolico may choose, but is not required, to allow the Customer to designate in writing one (1) or more attributes of the general appearance, design, dimensions, or other attributes of a Custom Product as a Key Attribute for purposes of these Terms.

Hydrolico reserves the right to authorize or make changes to any attribute of a Custom Product, other than a Key Attribute, as is reasonably necessary for Hydrolico to manufacture that Product in accordance with Hydrolico's design, material procurement, and manufacturing capabilities. Notwithstanding the foregoing, Hydrolico reserves the right to authorize or make changes to any Custom Product for which the Customer signed drawings prior to January 16, 2015, including any Key Attribute and its related signed drawings, without obtaining the consent of the Customer.

The Customer is fully liable for the design, quality, and functionality or lack thereof of any Custom Product, including, but not limited to, any cylinder, hydraulic power unit, or other Products. Hydrolico assumes no liability for the operation or use by the Customer or the end user of such Custom Product. All drawings, special tools, dies, models, templates, and assemblies created, purchased or supplied by Hydrolico will be and remain the exclusive property of Hydrolico and the Customer will have no rights over them.

The Customer who provides drawings to Hydrolico states and guarantees that he has the Intellectual Property Rights (as defined in article 12) to these designs or authorization from the owner of these Intellectual Property Rights to have the Custom Products manufactured by Hydrolico.

10 Limited Warranty; Warranty Disclaimers

Unless otherwise specified, Hydrolico warrants Products manufactured by Hydrolico for a period of one (1) year from the date of purchase against failures, only to the extent that they are caused by faulty materials or faulty workmanship, provided that:

- a) his failure occurs during the use of the Product in accordance with the Product specifications provided by Hydrolico; and
- b) there was no disassembly, damage during shipping, abuse, misuse, misapplication, maintenance, modification, or improper installation or maintenance or repair of the Product.

Warranty coverage is conditional upon the Customer:

- a) notifying Hydrolico in writing of the warranty claim, within fifteen (15) days following the alleged malfunction;
- b) obtaining an RMA and a product return location from Hydrolico, unless Hydrolico chooses not to provide one;
- c) complying with all applicable Hydrolico procedures and instructions regarding the return of the Product;
- d) providing Hydrolico with a detailed written report on the circumstances of the alleged failure of the Product, including photos of the Product; and
- e) giving Hydrolico a reasonable amount of time to inspect the Product and investigate the claim.

Hydrolico's sole obligation under this limited warranty will be as follows: If, following the inspection conducted by Hydrolico of the Products returned in accordance with the above, the warranty described above applies, Hydrolico may, at its sole discretion, either refund the price paid by the Customer for the Product, or replace the Product or part and pay the shipping costs incurred as a consequence at the lowest rate for shipping from the Hydrolico Customer's site to a Hydrolico product return site. If following inspection by Hydrolico of the returned Products, the warranty described above does not apply, inspection fees, plus shipping and handling, will be invoiced to the Customer by Hydrolico.

Hydrolico does not guarantee or provide technical advice as to the suitability of a Product for the Customer's application or use. The Customer is solely responsible for determining whether a Product meets its needs and for complying with all applicable laws, ordinances, regulations, rules, and standards relating to the installation, maintenance, use, dismantling, demolition, and disposal of each Product.

THE FOREGOING CONSTITUTES THE EXCLUSIVE REMEDY OF THE CUSTOMER AND THE EXCLUSIVE LIABILITY OF HYDROLICO. THIS GUARANTEE CANNOT BE ASSIGNED OR TRANSFERRED BY THE CUSTOMER. THIS WARRANTY SUPERSEDES ANY OTHER WARRANTY, ORAL OR WRITTEN, EXPRESS OR IMPLIED. ANY WARRANTY OF MERCHANTABILITY, CONSISTENT WITH A PARTICULAR USE. ANY OTHER WARRANTIES NOT SPECIFICALLY PROVIDED HEREIN ARE SPECIFICALLY EXCLUDED. THE SALE OF HYDROLICO PRODUCTS UNDER ANY OTHER WARRANTY IS NOT AUTHORIZED.

ANY PRODUCT SOLD BY HYDROLICO THAT IS NOT MANUFACTURED BY HYDROLICO IS SOLD ON AN "AS IS" AND "WITH ALL FAULTS" BASIS. WITH RESPECT TO SUCH A PRODUCT, HYDROLICO EXCLUDES AND DISCLAIMS ALL WARRANTIES, EXPRESS OR IMPLIED, WRITTEN OR ORAL, AS WELL AS ANY WARRANTY OF COMPLIANCE OR FITNESS FOR A PARTICULAR USE.

Many Products sold by Hydrolico are manufactured by third parties and are guaranteed by their manufacturers. Any third party warranty for any item in the Hydrolico printed catalogue or website can be obtained from: Hydrolico International Inc., 55, Théodore-Viau, Terrebonne, Québec, Canada J6Y 0J8.



11 Limitation of Liability

IN NO EVENT, REGARDLESS OF THE SOURCE OF HYDROLICO'S LIABILITY, SHALL HYDROLICO BE LIABLE TO THE CUSTOMER OR ANY THIRD PARTY FOR ANY INDIRECT, CONSEQUENTIAL, PUNITIVE, OR EXEMPLARY DAMAGES, INCLUDING, BUT NOT LIMITED TO, ANY LOSS OF PROFITS OR LOSS OF USE, REGARDLESS OF FAULT OR CAUSE, EVEN IF HYDROLICO IS ADVISED IN ADVANCE OF THE POSSIBILITY OF SUCH DAMAGES.

UNDER NO CIRCUMSTANCES WILL HYDROLICO BE LIABLE TO THE CUSTOMER FOR ANY TOTAL AMOUNT EXCEEDING THE PURCHASE PRICE OF THE PRODUCT(S) FOR WHICH A CLAIM IS MADE AS WELL AS DELIVERY COSTS, IF APPLICABLE. THE CUSTOMER WAIVES ANY COMPENSATION AGAINST PAYMENTS DUE ON HIS ORDERS. THE CUSTOMER ALSO WAIVES HIS RIGHT TO THE DEFENCE OF NON-PERFORMANCE. THE PROVISIONS OF THIS SECTION

DISTRIBUTE THE RISKS BETWEEN HYDROLICO AND THE CUSTOMER. HYDROLICO'S PRICES REFLECT THIS DISTRIBUTION OF RISKS AND, WITHOUT THIS DISTRIBUTION AND LIMITATION OF LIABILITY, HYDROLICO WOULD NOT HAVE CONCLUDED ANY AGREEMENT WITH THE CUSTOMER FOR THE SALE OF PRODUCTS. THE CONDITIONS IN THIS SECTION WILL ALSO APPLY TO ANY SUPPLY CONTRACT AND ANY SUPPLY PLAN BETWEEN HYDROLICO AND THE CUSTOMER WITH NECESSARY ADJUSTMENTS.

12 Intellectual Property

Hydrolico's exclusive liability for the violation of patents, trademarks, copyrights, trade dress, trade secrets, or similar rights, and the Customer's exclusive remedy for such infringement will be as follows: Hydrolico shall defend, indemnify and hold harmless the Customer, including retaining legal counsel chosen at Hydrolico's discretion, with respect to any legal proceedings brought against the Customer by a third party for infringement of patents, trademarks, copyrights, trade dress, and trade secrets ("Intellectual Property Rights") resulting solely from the sale by Hydrolico of Products designed and manufactured solely by Hydrolico. The Customer must cooperate fully with Hydrolico in the defense and must not take any position unfavourable to Hydrolico's defense against such action. The foregoing commitment does not apply unless Hydrolico has been informed in writing and in detail by the Customer as soon as possible of any infringement claim and has been given the opportunity to consent and defend them. Hydrolico will have the right to resolve any claim in the manner agreed between Hydrolico and the Customer.

Notwithstanding the foregoing, Hydrolico shall have no obligation to defend or indemnify the Customer in the event of infringement claims based on:

- (i) information or designs provided or specified in whole or in part by the Customer;
- (ii) offences resulting from the amendment;
- (iii) a combination or the use of any Product in a system; or (iv) Products that are not manufactured solely by Hydrolico.

Under these Terms, to the extent that any product supplied is manufactured in accordance with the drawings, samples, manufacturing specifications, or other information or content provided by the customer, the customer must indemnify and hold Hydrolico harmless from all damages, costs, and expenses resulting from a claim that said product manufactured by Hydrolico under the direction and design of the Customer, in whole or in part, or the use of it infringes any foreign or national patent right.

The Customer agrees to undertake the defense of any such claim against Hydrolico at its own expense or to reimburse Hydrolico for its defense costs and expenses, including, without limitation, all reasonable extrajudicial fees, costs, and disbursements, incurred as a result of any such claim or claims, in addition to any other obligations of the Customer as set forth herein. Such a lawsuit can only be resolved with the agreement of Hydrolico.

13 Entire Agreement

These Terms, including, without limitation, any Purchase Order and related Product Specifications, if any, represent the entire agreement between the parties with respect to the subject matter hereof and supersede all other prior agreements, understandings, and accords, whether oral or written. No provision of these Terms may be amended, modified, revoked, cancelled, or terminated except in writing and signed by each of the parties hereto.

The Customer may not assign any rights or obligations under these Terms, any Purchase Order, or any Product Specification, in whole or in part, without the prior written consent of Hydrolico.

14 No waiver

If a party fails to exercise any of its rights granted hereunder, this does not constitute a waiver or modification of its rights under these terms and conditions; each party may, within the time prescribed by law, institute legal proceedings to exercise its rights under these terms and any previous failure or delay in doing does not constitute a defense which is enforceable.

15 Divisibility of the Conditions

If, for any reason, any provision of these Terms is deemed invalid, that invalidity will not affect any other provision of these Terms that is not considered invalid, and each such other provision shall remain in full force and effect, to the fullest extent of the law.

If any provision of these Terms is deemed partially invalid, that invalidity will in no way affect the remainder of that provision, and the remainder of that provision, together with all other provisions of these Terms, shall remain in full force and effect to the fullest extent of the law.

16 Force Majeure

Notwithstanding anything else contained herein to the contrary, neither party shall be liable for any failure or delay in performing its obligations (except for payment obligations) under these Terms to the extent that such breach or delay is due to "Force Majeure", including but not limited to cases of natural disasters, fires, floods, power outages, wars, civil unrest, epidemics, pandemics, sabotage, terrorism, accidents, insurrections, blockades, embargoes, storms, explosions, acts of a public enemy, social conflicts (whether or not the claims of employees are reasonable and/or to the extent that the party is able to satisfy), the failure of public carriers, Internet service providers, or other communication devices, the acts of cybercriminals, the acts of any government agency (civilian or military, foreign or domestic), the failure or delay of third parties or government agencies for which a party obtains or is required to obtain approvals, authorizations, licenses, franchises, or permits; the inability to obtain labor, materials, electricity, equipment, transportation, or other circumstances that are unforeseeable and unavoidable). Such delays will not constitute a breach or failure to perform these Terms or any part of them and the date by which obligations hereunder must be fulfilled will be extended by a period equal to the time lost as a result of these delays. Neither party shall be held liable to the other for claims of liability, damages, or other losses caused by or resulting from Force Majeure events.

17 Sending Notices in Writing

Except as otherwise provided herein, any notice required or authorized to be given in accordance with the provisions of these Terms must be in writing and shall be deemed to have been sent when it is (a) delivered in person or (b) deposited to the Canadian Postal Service, registered or certified, and prepaid, or (c) sent by electronic means (email or otherwise) that allows the sender to demonstrate that the notice was in fact received by the recipient. In each case, this notice must be delivered or addressed to the contact information indicated on the Customer's account for the purposes of placing orders with Hydrolico (in the Customer's case) or Hydrolico International Inc., 55, Théodore-Viau, Terrebonne, Quebec, Canada J6Y 0J8, or as otherwise provided in writing by the parties.



18 Compensation

THE CUSTOMER AGREES TO DEFEND AND INDEMNIFY AND HOLD HARMLESS HYDROLICO FROM ANY CLAIMS FOR LOSSES, COSTS, EXPENSES (INCLUDING, WITHOUT LIMITATION, REASONABLE EXTRAJUDICIAL COSTS, FEES, AND DISBURSEMENTS), DEMANDS, LIABILITY, CAUSE OF ACTION, OR DAMAGES OF ANY KIND, ARISING OUT OF OR IN ANY WAY RELATED TO:

- a) ANY MISUSE, ALTERATION, MODIFICATION, INSTALLATION, OR MISAPPLICATION OF ANY PRODUCT;
- b) USE OF ANY PRODUCT OTHER THAN IN ACCORDANCE WITH HYDROLICO INSTRUCTIONS AND SPECIFICATIONS;
- c) ANY BREACH OF FEDERAL, STATE, OR LOCAL LAWS, RULES, OR REGULATIONS; OR
- d) ANY BREACH OF ANY OF THE TERMS SET FORTH HEREIN OR OTHER BREACH OF ANY CUSTOMER AGREEMENT WITH HYDROLICO.

19 No third-party beneficiaries

Except as expressly provided herein, these Terms are for the sole benefit of the parties hereto and their respective successors and assigns and nothing hereof, express or implied, is intended or will confer upon any other person any right, benefit, or remedy of any kind under these Terms.

20 Applicable Law

These Terms, and any agreed amendments to them, will be governed in all respects by the laws of Quebec and the laws of Canada applicable there. Any legal claim relating to these Terms between Hydrolico and the Customer and/or to any Product sold to the Customer must be filed with a competent court in the judicial district of Terrebonne (Quebec, Canada), to the exclusion of any other court.

HC Hydro Custom

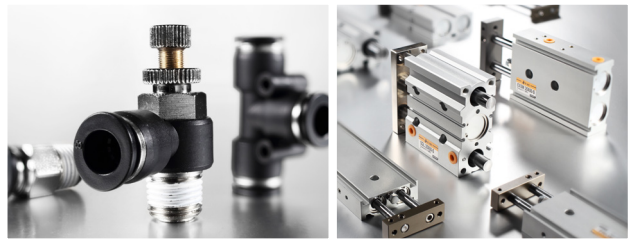
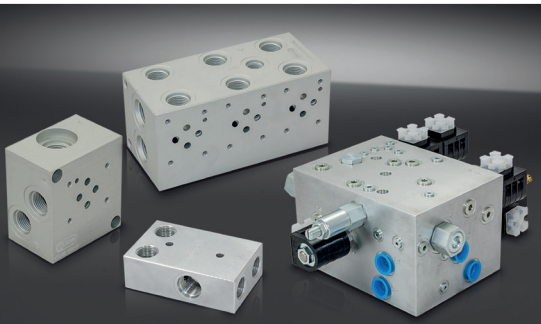
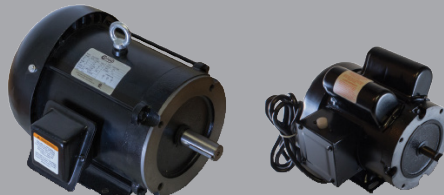
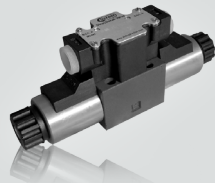

HYDROLICO
INTERNATIONAL

55, Théodore-Viau
Terrebonne (QC) J6W 0J8
Canada

Tel : 1 877 628-6644
Fax : 450 628-7566

www.hydrolico.com



3200 Northridge Dr. NW
Walker (MI) 49544
USA

Tel : 616 228-9350
Fax : 616 805-4075

www.hydrolico.com